



P S O M A S



Los Angeles Valley College Central Plant Study

Final Submittal—Issued December 8, 2011

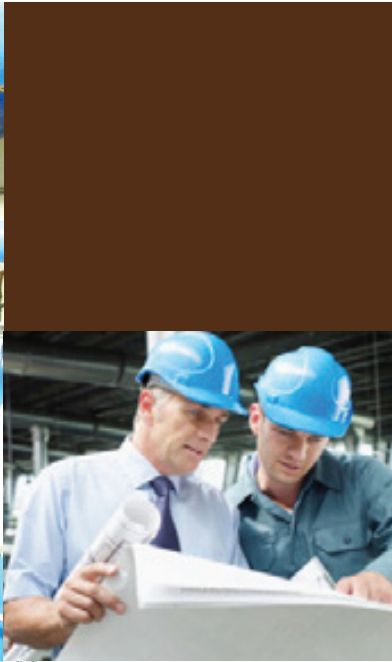

The vision to change. The integrity to sustain.

Executive Summary

This is a report of our findings of the central plant engineering study for Los Angeles Valley College. The goal of the study was to determine how much capacity the central plant must produce to cover the heating and cooling loads of the full build-out of the College's Horizon-2 Master Plan. During the course of this study we determined the total building loads connected to the plant (present & future buildings, plus a spare building). We studied the hot and chilled water delivery systems' ability to meet the future needs. We compared the existing central plants heating and cooling capacities to the projected needs of the college. Our findings include the piping system deficiencies, and three options to expand the cooling capacity of the central plant to meet the Master Plan build-out. We compared the construction costs and energy costs of each option to find the estimated simple payback period and the 20-year life cycle cost.

We found that the existing equipment can make enough chilled and hot water to support the buildings' loads. This option is not recommended because the energy costs are higher than any of the three options we developed. This option also relies on an aging chiller, and has no spare capacity. Two of our options have very good payback periods and will increase the life span of the central plant. Each of our options would improve the energy efficiency of the central plant.

Our three options included:

- Ice thermal energy storage (TES) system for the MAPA building
- A new larger, variable speed chiller at the central plant
- A 6,900-ton-hr chilled water TES system.

The MAPA ice TES option works to reduce the cooling loads the central plant must support during the peak times. It also helps to support MAPA during off hours. This option had the lowest first cost, and a good payback period of 9-years.

The new larger chiller option had the second lowest first costs, but an unacceptable payback period over 40-years. The new chiller would have improved energy efficiency over the existing unit it would replace.

The chilled water TES tank system had the highest first cost, but its performance reducing electrical costs was good enough to have a payback period of 7.6-years. The biggest drawback of the chilled water TES tank is its physical size. The tank will be 25ft high and 65ft in diameter. Locating it next to the central plant was not practical, and we found that an underground tank in the parking lot near Burbank Boulevard to be a better location.

We found that the chilled water and heating hot water lines in the east tunnel to be undersized for the Master Plan build-out. We recommend replacing the pipes with larger ones.

Our study of the future campus heating needs indicated that the existing boilers and solar hot water system will be adequate. Other than the main line upsize, we did not find a reason to modify or expand the central plant heating system.



Existing Central Plant

The central plant at Los Angeles Valley College provides heating and cooling to the major campus buildings. The plant distributes hot and cold water to the buildings through an underground pipe network. High efficiency copper tube boilers make the hot water. A combination of chillers and ice thermal energy storage (TES) provide the campus with chilled water. The underground piping runs through a tunnel system and some new and proposed sections of pipe will be direct buried lines.

The plant was designed to be energy efficient and to reduce the electrical and natural gas costs of the College. The plant uses the ice TES and solar hot water storage to shift electrical demand off peak rates. The solar-thermal collection system has three large hot water storage tanks, and two heat exchangers. The solar thermal system serves both the heating and cooling of the campus. Solar heating is provided through a shell & tube heat exchanger. The solar cooling is achieved with the employment of a hot water absorption chiller. The other heat exchanger is used to dump heat to prevent the solar system from getting too hot.

There is an electrical centrifugal chiller that is used to make ice for the thermal energy storage system. The ice chiller makes ice at night during base electrical rate hours to shift the electrical demand. The stored thermal energy is then discharged to the campus during the peak hours. There is another centrifugal chiller that is used during low-peak and base-rate hours to support the campus cooling needs. The absorption chiller is used as side-stream chiller in conjunction with ice heat exchanger to support the peak loads. The combination of the heating and cooling equipment allows for a sequence of operations that is energy efficient and reduces energy costs by reducing peak time demand and consumption.

The existing 900-ton chiller near the end of its life cycle. Also the supporting chilled water pumps are at the end of their life cycles (replacement components are no longer readily available for the pumps). We have included the replacement of the chiller and pumps in each of our costs estimates later in the report.

The central plant heating system is comprised of seven hot water boilers and a solar thermal heat exchanger. The solar heating system is used when it is cool enough that the absorber will not be needed, and also during low season. The hot water is more valuable for electrical peak load shedding during LADWP's high season. The seven boilers are sequenced on as needed to match the campus heating demand.

The central plant heating system is comprised of seven hot water boilers and a solar thermal heat exchanger. The solar heating system is used during low season for electrical rates, during high season it is used for the absorption chiller. The seven boilers sequence on as needed to match the campus heat demand.



Current Central Plant Equipment

CH-1 – McQuay Centrifugal Chiller

- Capacity 900-Tons
- EWT/LWT 55/44F
- Chilled Water Flow Rate 2,160GPM
- Condenser Water Flow Rate 2,710GPM

CH-2 – McQuay Centrifugal Ice Making Chiller

- Capacity 400-Tons
- EWT/LWT 32/25F
- Chilled Water Flow Rate 1,500GPM
- Condenser Water Flow Rate 1,600GPM

CH-3 – Broad Absorption Chiller

- Capacity 350-Tons
- EWT/LWT 56/49F
- Chilled Water Flow Rate 1,200GPM
- Condenser Water Flow Rate 2,024GPM

CT-1 - BAC Cooling Tower

- Capacity 750-Tons
- EWT/LWT 92/82F
- Condenser Water Flow Rate 2,250GPM

CT-2 - BAC Cooling Tower

- Capacity 900-Tons
- EWT/LWT 92/82F
- Condenser Water Flow Rate 2,710GPM

B-1 thru B-5 – Boiler

- Capacity 1,670MBH
- EWT/LWT 140/180
- Hot Water Flow Rate 380GPM

B-6 and B-7 – Boiler

- Capacity 4,400MBH
- EWT/LWT 140/180
- Hot Water Flow Rate 220GPM

IT-1 thru IT-6 – BAC Ice Storage Tanks

- Capacity 700-Ton-Hrs

CHWP-1 & CHWP-2 – Glycol Loop

- Flow 1,200GPM
- Head 75FT

CHWP-3 and CHWP-4 – Campus Loop

- Flow 1,000GPM
- Head 140FT

CHWP-5 – Campus Loop

- Flow 1,950GPM
- Head 140FT

CWP-1 & CWP-2

- Flow 1,125GPM
- Head 50FT

CWP-3

- Flow 2,710GPM
- Head 50FT

HWP-1 and HWP-2 – Campus Heating Loop

- Flow 542GPM
- Head 140FT

HWP-8 and HWP-9 – B-6 & B-7 Primary Pumps

- Flow 252GPM
- Head 35FT

HWP-10 and HWP-11 – Absorber & HX-2 Pumps

- Flow 265GPM
- Head 50FT

SHWP-1 and SHWP-2 – Solar System Pumps

- Flow 332GPM
- Head 90FT

HX-1 – Ice to Chilled Water

- Flow 2,400GPM

HX-2 – Hot Water

- Flow 530GPM
- Capacity 5,900MBH

Campus Building Cooling Loads

We determined the maximum campus cooling loads based on the campus Master Plan. The current Master Plan has approximately 764,850GSF of buildings connected to the central plant. We added one 60,000GSF general-purpose building to the list at the request of the college for our calculation purposes. The completion of all buildings plus the additional building results in 824,850GSF connected to the central plant.

We determine the load for each building based on actual conditions that are known, the central plant record drawings, the Utility Master Plan, any building drawings available to us, and our experience with similar colleges. At any given time a single building may use 100% of its cooling capacity, but extensive experience has shown that not all buildings are at peak loads at the same time. A diversity factor is applied to the total campus loads to account for this fact. For LAVC we used a diversity factor of 80%.

There are 23 buildings on our list. Six are either in construction or under design at the time of this report. The loads we used for our study are shown in the table to the right. For some of the existing buildings we have a higher load than what is actually known (South Gym & Campus Center). We also expect many of the new buildings to be highly efficient and their loads will be less than what we used. Our findings indicate an average of 450GSF/Ton total load for the central plant to support. We feel this number is reasonable for a campus of this size.

The campus load varies throughout the day and the time of the year. We are interested in the peak loads to determine the maximum central plant capacity. The amount of time at actual peak conditions is only a fraction of the operating hours. It is important not to oversize the central plant to cover conditions that will only happen 2% of the operating hours.



Building	GSF	Design Peak Loads (Tons)	Building Notes	Labeled on Master Plan
Foreign Language	16,130	40	Existing	3
Engineering	24,145	60	Existing	6
South Gym	45,200	113	Existing	7
Liberal Arts (Business & Journalism)	20,660	52	Existing	19
Music Building & Recital Hall	16,441	41	Existing	11
Art	18,965	47	Existing	48
Ems/New Environment Center	22,590	56	Existing	8
Math	19,611	49	Existing	50
Planetarium	2,616	7	Existing	51
Behavioral Science	13,700	34	Existing	52
Humanities	19,400	49	Existing	53
Motion Picture/ TV Studio	4,700	12	Existing	54
Business Technology Center (Campus Center)	83,553	209	Existing	56
Allied Health Science	80,767	202	Existing	76
North Gym & DSPS Gym	37,963	95	Existing	67
Student Services Center & Annex	40,186	100	Existing	102
Library & Academic Resource Center	92,922	232	Construction	68
Media Arts/Performance Arts Center (MAPA)	62,000	405	Design Phase	V-11
Athletic Training Facility	18,000	45	Design Phase	V-13
Mcsc	25,000	63	Design Phase	V-16
Cwdc & Administration	70,000	175	Design Phase	V-12
Monarch (Student Union)	48,300	121	Design Phase	V-22
Instructional Building (Future)	60,000	150	Future	V-XX
Existing Loads		1,167		-
Total Loads	842,849	2,357		-
Diversified Peak Loads	80%	1,886		-



The graph to the right shows the expected campus loads for peak design conditions and the current operational capacity of the central plant. The output of the central plant is not enough to keep up with the expected demand at all times, however, it can keep up with approximately 70% of the peak demand. Modifications will be needed to meet the campus cooling demand at all times.

The plant output curve shows the peak load shaving strategy used to reduce electrical costs. The central plant has one electric chiller, an absorption chiller, an ice making chiller, and ice thermal energy storage (TES). During the LADWP peak rate hours the electric chillers are off and the ice TES and absorber chiller are on. During the low-peak and base-rate hours the electric chiller operates to meet demand. At night, and off-peak the electric ice making chiller works to charge the ice TES tanks.

CAMPUS LOADS VS. CENTRAL PLANT OUTPUT

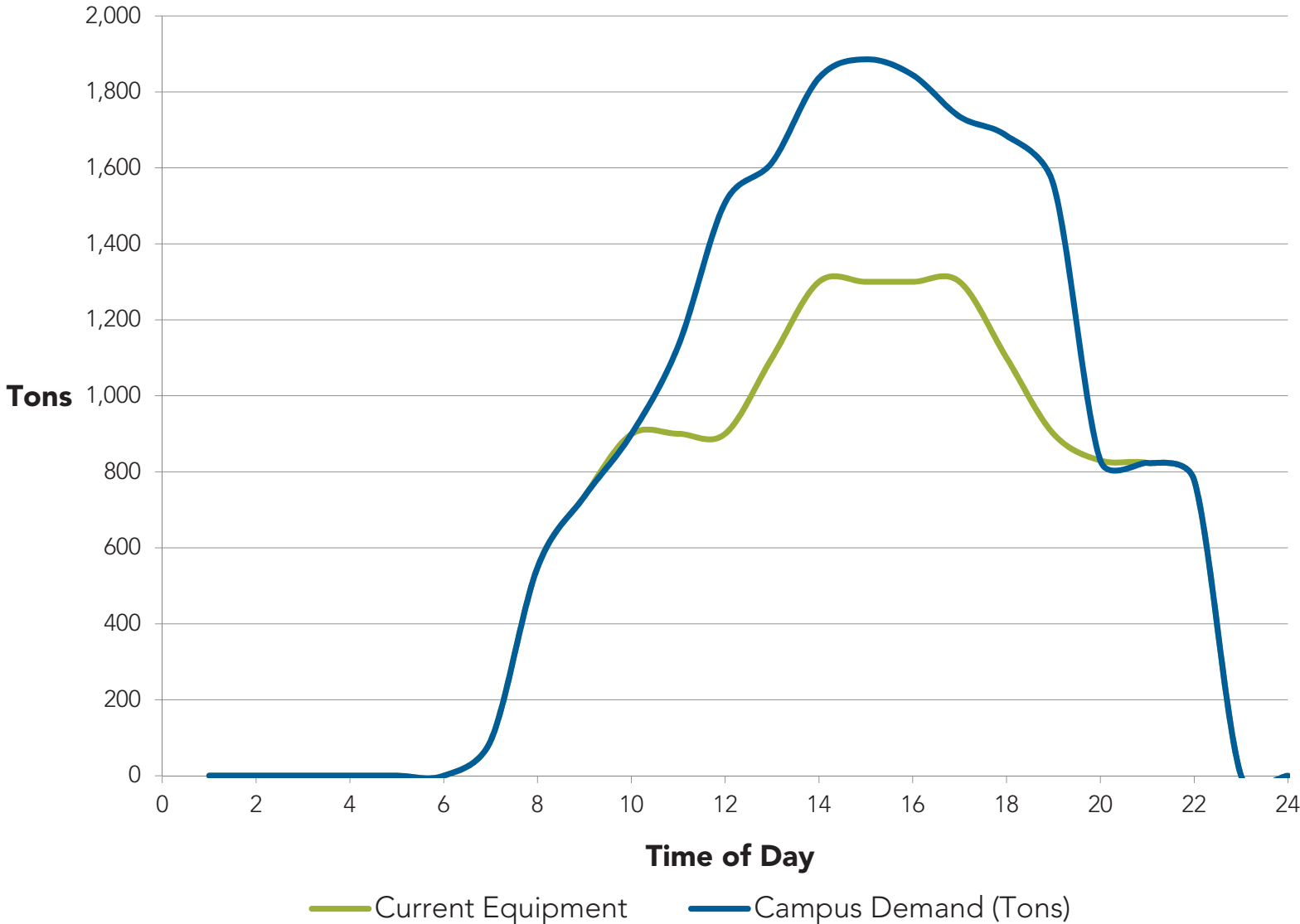

Delivery of the Chilled Water to the Campus



We determined the required flow rate of chilled water needed to each building. We calculated the flow rates in the main lines and in the lateral lines to each building. When we looked at the building lateral supply lines we did so without applying a diversity factor. Diversity was avoided here because any one building can be at peak demand and the piping must be sized to deliver this rate. We did apply the diversity factor to the main lines when calculating the flow rates.

Currently the College uses a temperature differential of 12°F for chilled water. There is a plan is to increase this to 16°F. The increased temperature differential will reduce the flow rate by 25%. This will reduce pumping energy and reduce the amount of upsizing of chilled water piping. If the College does not increase the temperature differential many of the lines will be undersized.

Building	CHW GPM @ 16ΔF
Foreign Language	60
Engineering	91
South Gym	170
Liberal Arts (Business & Journalism)	77
Music Building & Recital Hall	62
Art	71
EMS/New Environment Center	85
Math	74
Planetarium	10
Behavioral Science	51
Humanities	73
Motion Picture/ TV Studio	18
Business Technology Center (Campus Center)	313
Allied Health Science	303
North Gym & DSPS Gym	142
Student Services Center & Annex	151
Library & Academic Resource Center	348
Media Arts/Performance Arts Center (MAPA)	608
Athletic Training Facility	68
MCSC	94
CWDC & Administration	263
Monarch (Student Union)	181
Instructional Building (Future)	225

We examined the utility master plan for existing and planned chilled water pipe sizing. Each building lateral supply line must allow for full flow at peak conditions. But the main distribution lines only need to support the diversified loads (80% of peak). We used the values in the table to determine if the line size was adequate for the load. Exceeding the velocities in the table will result in excessive frictional losses. This results in increased pumping power, and the possibility of starving buildings of the required flow rate.

PIPE SIZING CHART

Pipe Size	Max Velocity	GPM
3	5.43	125
4	6.31	250
6	8.33	750
8	10.25	1600
10	10.25	2700
12	12.91	4500

We found seven potential trouble spots. Six are building connection laterals, four of which are buildings either in construction or in design. Two problems are for existing buildings, which may be operating OK. One problem is in the East Tunnel main line.

South Gym

170GPM in a 3" Line, for 7.6FPS

(75GPM in a 3" Line, for 3.3FPS)

This building is currently connected to the central plant. Our estimated cooling demand for the building may be too big and that may be why we see the pipe size as too small. If we adjust the flow rate to what has been observed on campus we get 75GPM which is OK.

Business Technology (Campus Center)

313GPM in a 4" Line, for 8FPS

(200GPM in a 4" Line, 5FPS)

This building is currently connected to the central plant. Our estimated cooling demand for the building may be too big and that may be why we see the pipe size as too small. If we adjust the building cooling demand to what has been observed on campus we get 200GPM, which is OK. This building is slated to be renovated and it will certainly become more energy efficient as a result.

Monarch Center

181GPM in a 3" Line, for 7.8FPS

This building has not been designed completely yet. There is opportunity to adjust the line size for actual demand.

LLRC Library

174GPM in a 3" Line, for 7.6FPS (Two locations)

This building is under construction. The master plan information we had may not match exactly what will be installed. The building is connected to a 6" main in the tunnel and we suspect the designer ran this size into the building.

Community Workforce Development Center (CWDC)

263GPM in a 3" Line, for 11FPS

This building has not been designed yet, so this is not yet an issue. 4" pipe size will be needed for the chilled water supply.

East Tunnel Main Line

870GPM in a 6" Line, for 9.5FPS

The demand for the MAPA building is higher than the master plan allowed for. The pipe in the east tunnel should be increased to 8" all the way to the MAPA building.

Pumping Systems

Given the fact that the chilled water entering/leaving temperature differential will be increased to 16F, the chilled water pumps are sufficient to supply the campus with water. There are three chilled water pumps to supply the campus loop. The total existing capacity is 3,950GPM. We projected the required capacity for full build-out to be 2,830GPM. There is a reserve pumping capacity of 1,120GPM. This means one of the chilled water pumps will be a redundant pump for back-up.



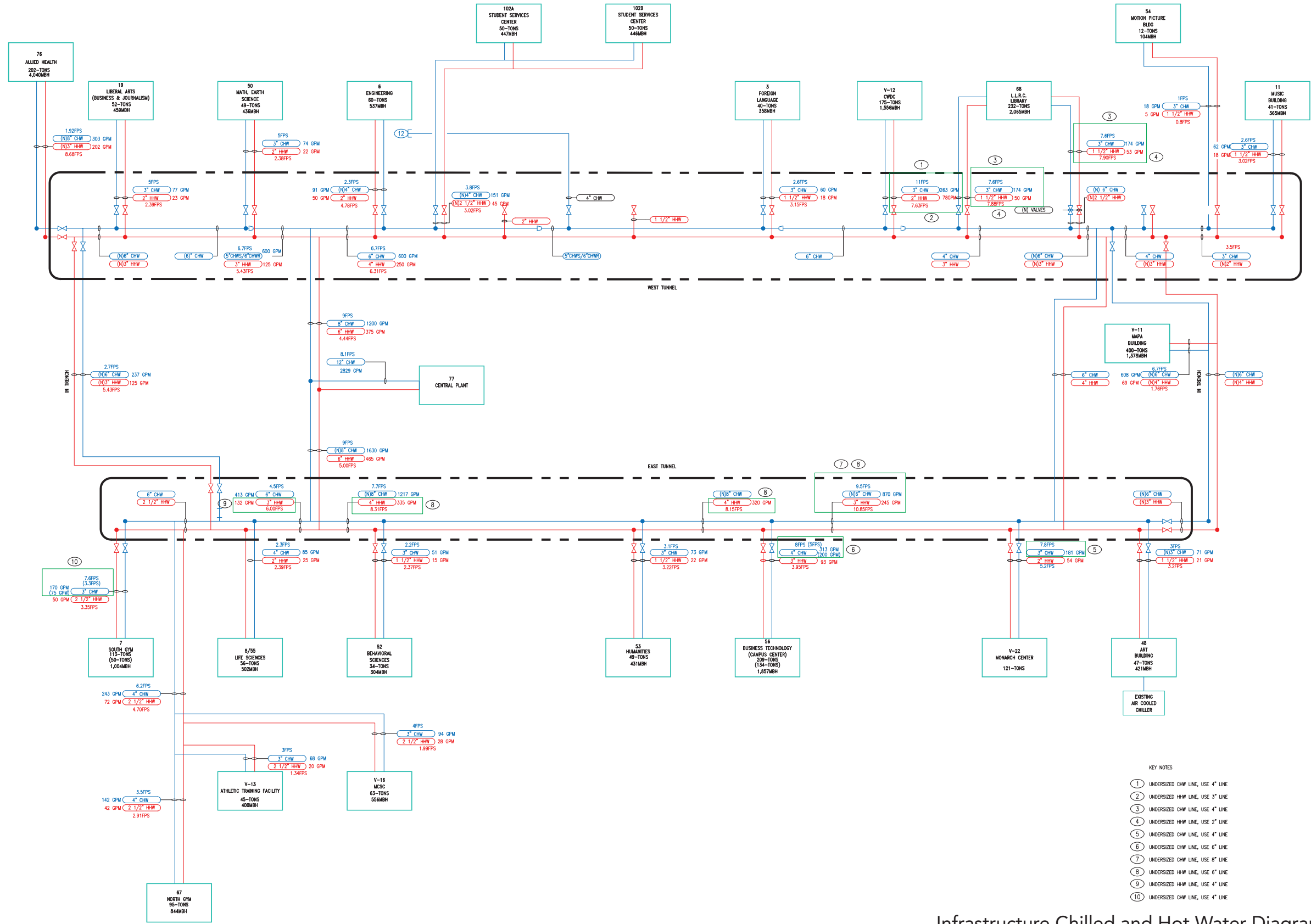

- KEY NOTES
- ① UNDERSIZED CHW LINE, USE 4" LINE
 - ② UNDERSIZED HWH LINE, USE 3" LINE
 - ③ UNDERSIZED CHW LINE, USE 4" LINE
 - ④ UNDERSIZED HWH LINE, USE 2" LINE
 - ⑤ UNDERSIZED CHW LINE, USE 4" LINE
 - ⑥ UNDERSIZED CHW LINE, USE 6" LINE
 - ⑦ UNDERSIZED CHW LINE, USE 8" LINE
 - ⑧ UNDERSIZED HWH LINE, USE 6" LINE
 - ⑨ UNDERSIZED CHW LINE, USE 4" LINE
 - ⑩ UNDERSIZED CHW LINE, USE 4" LINE

Infrastructure Chilled and Hot Water Diagram

Central Plant Modification Options

We explored four options to increase the output capacity of the plant to meet the expected loads. There are many options available, but we looked for ones that made use of the existing systems, do not require another structure, will physically fit on campus, and keep with the electrical peak shavings goal. For a base line we produced a graph that shows the electrical demand for cooling if the central plant did not have a TES system. This curve represents the combined campus building cooling loads for a peak day.



The peak cooling loads occur at the exact time of the highest peak electrical rates. This is why TES systems are so valuable; they reduce the energy consumption and demand during peak.

CAMPUS ELECTRICAL DEMAND

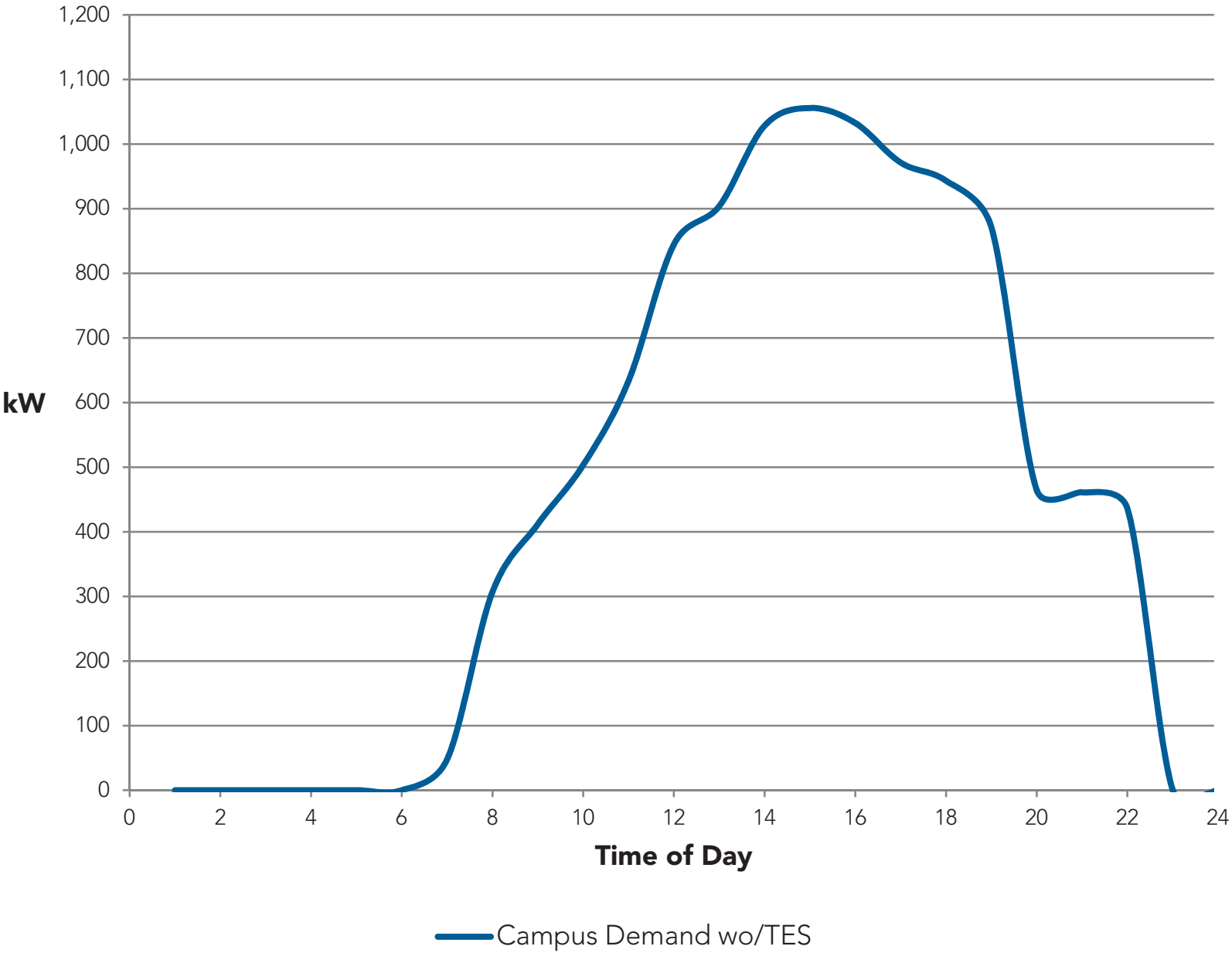

Option One – Run with Existing Equipment (Base Case)

We found by modifying the operations of the central plant that it can support the future needs. This will require operating the electrical chillers during the peak period. The chilled water line in the east tunnel will have to be upsized to support this option.

For the existing equipment operations to support the new loads the following modifications are needed.

1. Increase the discharge period of the ice TES from 6-hrs to 8-hrs
2. Operate the 900-ton chiller during peak hours
3. Operate the 400-ton chiller in chilled water mode during low-peak hours
4. The absorber chiller operates as designed; 4-hrs through peak

The ice TES capacity is 4200-ton-hrs. It was designed to supply 950-tons during the 4-hr peak time and 2-hrs of mid peak. In this option we propose to reduce the output of the TES but expand the time it runs. Between 11:00AM to 7:00PM the ice TES will discharge.

From 7:00AM to 10:00PM the 900-ton chiller will be available operate to meet the campus demand.

Between 1PM and 5PM the 350-ton absorber comes on line.

After 5PM and to 7PM the 400-ton chiller will be needed to support the loads. The chiller will operate in chilled water mode and as such will have 450-tons of capacity.

After the campus is closed the 400-ton chiller will be in ice making mode. The ice TES will be completely charged in 11-hours.

This option has the following advantages:

1. The lowest first cost
2. The ice TES & Absorber provide peak shavings
3. The highest demand occurs after peak, on mid-peak.

This option has the following disadvantages:

1. Highest electrical peak demand and consumption, hence the biggest energy bill
2. It relies on the 10+-year old 900-ton chiller.
3. No spare capacity

OPTION 1—CAMPUS ELECTRICAL DEMAND

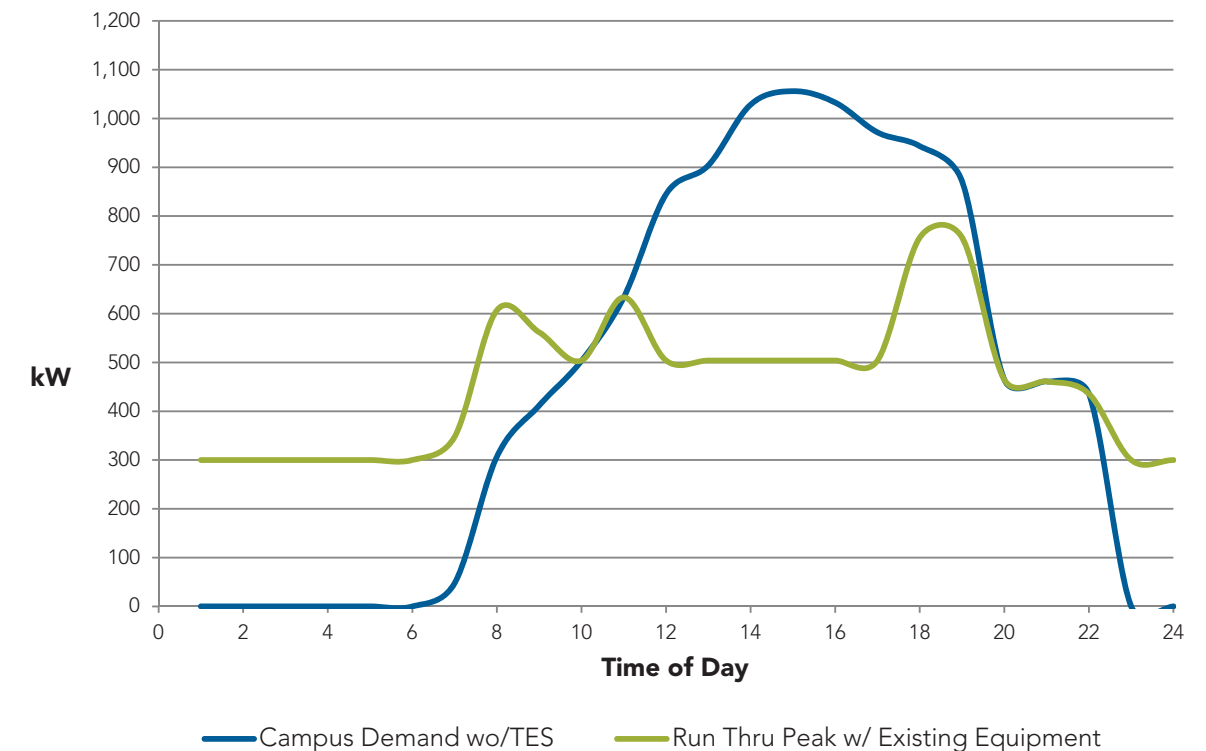

Option One	Demand (kW)		Consumption (kWh)			Cost
	Peak	Low	Peak	Low	Base	
LADWP A3 Rates (\$)						
Peak Demand	9.00000	504				\$4,536
Low Peak Demand	3.00000	756				\$2,268
High Consumption	0.04390		2,016			\$89
Low Consumption	0.03764			5,881		\$221
Base Consumption	0.01755				3,055	\$54
					Total	\$7,167

Estimated costs for peak day electrical demand and consumption only. This ignores all other campus electrical usage, LADWP charges, and pumping energy. This information is for comparison of the four examples in this report, and does not represent the total energy bill of the central plant.

Option Two – Add a TES System to MAPA and Utilize Existing Equipment

The Media Arts/Performing Arts (MAPA) building adds a significant load to the central plant. According to the design drawings it was sized for 400-tons peak load. This option adds an ice TES system to the MAPA building to cover the loads during peak rates. This removes some burden from the central plant. But it still is necessary to run an electric chiller during peak, but at half the rate of Option One.

The equipment needed at MAPA would be:

1. A 160-ton air-cooled ice duty chiller
2. Ice TES tanks with 1600-ton-hrs of capacity
3. A heat exchanger and chilled water pumps

The sequence of operation would be as follows:

1. At night, off-peak the ice chillers at the central plant and MAPA make ice.
2. During the campus business hours the central plant 900-ton chiller operates to meet loads
3. During peak hours the MAPA ice TES covers the building's loads completely
4. The central plant ice TES operating hours are expanded much the same as Option One
5. The absorber only operates as designed during peak
6. The central plant's 400-ton ice chiller only makes ice.

The chart to the right shows the electrical demand that this option will use. The electrical demand and consumption is reduced during peak rates as compared to the base case. The peak demand is reduced from approximately 500kW to less than 300kW.

The option also reduces the amount of water flowing through the chilled water distribution pipes. It removes the concern of the main line being undersized. During peak the MAPA building chilled water lines from the central plant would be isolated, so that the building is completely on its internal system.

This strategy could also be used to support weekend of nighttime performances at MAPA without bringing on the central plant. Either ice could be used or the chiller could run to support these off-hours loads.

Option Two Advantages:

1. Greatly reduced peak demand & consumption
2. 2nd Lowest cost to build
3. Removes the need to upsize the chilled water distribution lines in the east tunnel
4. MAPA can be supported off-hours and weekends without the central plant.
5. The 900-ton chiller is at part load during peak, so there is spare capacity available.

Option Two Disadvantages:

1. Takes up space for new mechanical equipment at MAPA
2. Additional mechanical equipment to maintain
3. An air-cooled chiller is less efficient than a water-cooled unit.

OPTION 2—CAMPUS ELECTRICAL DEMAND

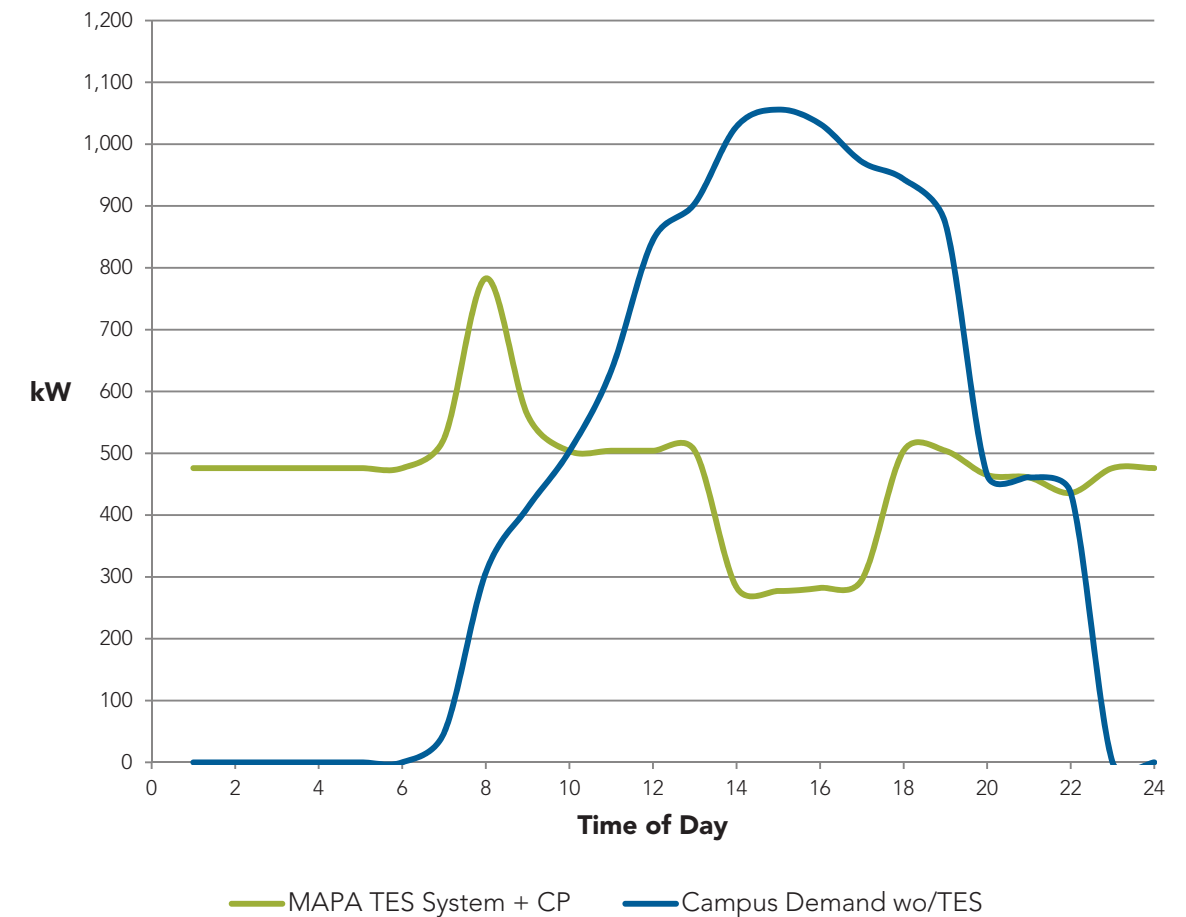

Option Two	LADWP A3 Rates (\$)	Demand (kW)		Consumption (kWh)			Cost
		Peak	Low	Peak	Low	Base	
Peak Demand	9.00000	295					\$2,658
Low Peak Demand	3.00000		504.00				\$1,512
High Consumption	0.04390			1,137.83			\$80
Low Consumption	0.03764				5598.40		\$211
Base Consumption	0.01755					4,655	\$82
						Total	\$4,512

Estimated costs for peak day electrical demand and consumption only. This ignores all other campus electrical usage, LADWP charges, and pumping energy. This information is for comparison of the four examples in this report, and does not represent the total energy bill of the central plant.

Option Three – Replace CH-1 with a Variable Speed 1400-ton Chiller

We looked at replacing the existing 900-ton electric chiller (CH-1) with a variable speed chiller with 1400-tons capacity. This plan would use the new chiller to cover loads during all business hours, but the ice TES system and absorber will still be used to reduce the peak loads. The advantage of a variable speed chiller is improved energy performance, especially during part loads. We recommend a chiller with dual compressors so that it can run extremely efficient at loads as low as 20% of rated capacity.

A new cooling tower and condenser water pumps will be needed at the plant to support the larger chiller. It would replace the existing towers and would handle all three chillers.

The sequence of operations would be as follows:

1. The ice chiller operates at night, as designed to charge the ice TES
2. The new chiller will operate during business hours to cover all loads
3. During peak hours the TES system and absorber will operate as designed to shave the peak loads.

The new chiller will only operate at 25% of capacity during the peak period. The peak shaving is improved over both Option One and Two. It drops to nearly 450kW.

Option Three Advantages:

1. Greatly reduced peak demand & consumption as compared to the base case and Option Two
2. New chiller will have long life span.
3. The new chiller is at part load during peak, so there is spare capacity available.

Option Three Disadvantages:

1. Low-peak demand and consumption only a slight improvement over Option One
2. Central Plant Electrical service will be upgraded
3. Structural reinforcements to central plant building to support new cooling tower
4. High construction cost and poor payback period

OPTION 3—CAMPUS ELECTRICAL DEMAND

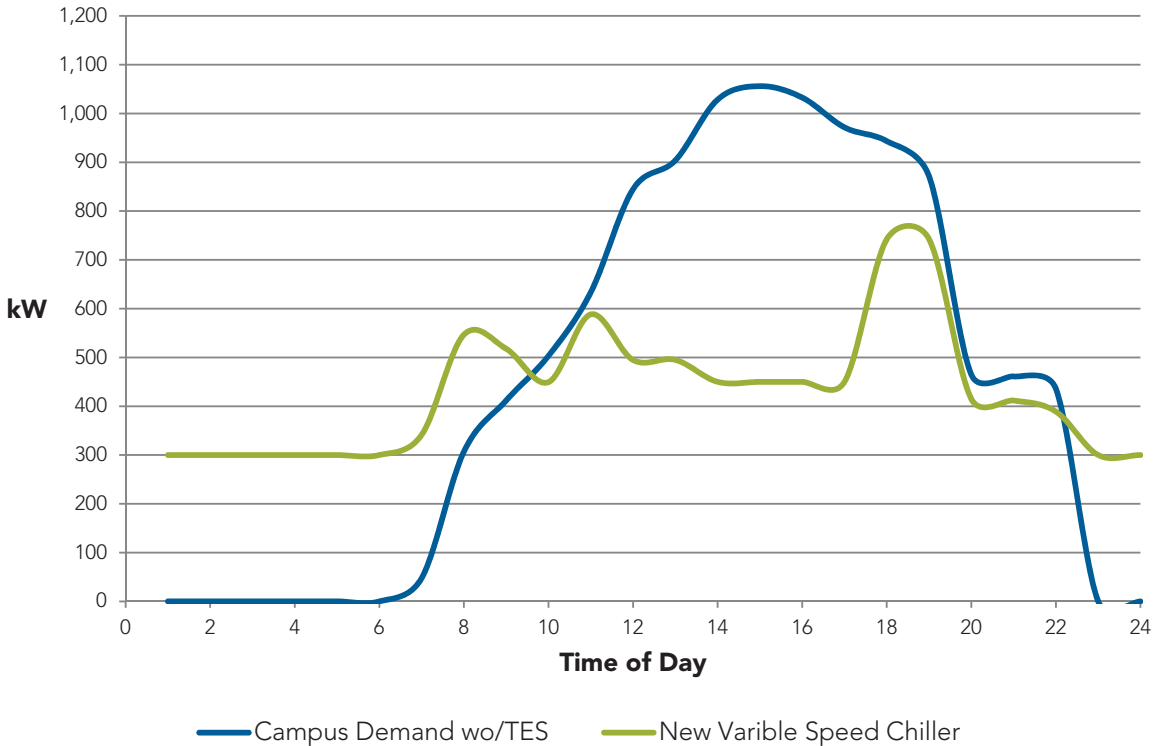

Option Three	LADWP A3 Rates (\$)	Demand (kW)		Consumption (kWh)			Cost
		Peak	Low	Peak	Low	Base	
Peak Demand	9.00000	450					\$4,050
Low Peak Demand	3.00000		742.68				\$2,228
High Consumption	0.04390			1,800.00			\$79
Low Consumption	0.03764				5,545.90		\$209
Base Consumption	0.01755					4,338	\$76
						Total	\$6,642

Estimated costs for peak day electrical demand and consumption only. This ignores all other campus electrical usage, LADWP charges, and pumping energy. This information is for comparison of the four examples in this report, and does not represent the total energy bill of the central plant.

Option Four – Add Chilled Water TES Tank to Campus

This option places a chilled water storage tank with a capacity of 6900-ton-hrs on campus. The tank would be approximately 25ft high and 65ft in diameter. The TES tank completely shaves the peak loads and reduces the mid peak loads as well. The existing systems remain in operation. The existing 900-ton would be replaced with a similar sized machine to meet the new chilled water temperature requirements. (39°F LWT/60°F EWT). This new chiller would be used at night to charge the chilled water tank, and to support loads during base-rate and low-peak times.

During most of the year the ice system can be taken out of operation because the chilled water TES system would be able to support the campus. This is a big advantage because making ice is much more energy intensive than producing chilled water.

During the winter season the chilled water TES tank will only need to be charged once or twice a month. During the other cool times charging the tank may only be done once a week. The amount of time the chillers operate will be greatly reduced as a result. Overall maintenance costs and electrical costs will be lower with this option than the other three.

The sequence of operations will be:

1. At night the 900-ton chiller will charge the chilled water TES
2. At night the 400-ton ice chiller will charge the ice TES
3. During low-peak periods the 900-ton chiller will limited to 75% capacity to reduce demand
4. During low-peak the chilled water TES will support the loads in conjunction with the 900-ton chiller

5. During high peak all loads will be supported by a combination of the two TES systems and the absorber

TES Tank Design and Location

The chilled water TES tank is rather large and would not work well as an above ground tank at Los Angeles Valley College. We propose to locate it underground and out of site. An underground tank is best constructed from concrete. A concrete tank has better thermal performance as compared to a steel tank. A concrete tank will need less maintenance and will have a very long life span (over forty years).

We looked at various site location on campus for a TES tank. We kept in mind the following parameters:

- A. Do not disturb finished spaces
- B. Constructability
- C. Proximity to Central Plant

Ideally we like to be right next to the Central Plant, but this is not feasible. There are main electrical duct banks in the area, which would be extremely difficult and expensive to relocate. Digging the hole for the tank in this area would be expensive due to the need for vertical shoring, and would bring heavy construction equipment into a congested area of campus. So for these reasons we moved away from the plant to find a suitable site.

We looked at using the green field just west of the Student Services building. This spot would be difficult to construct without major disruptions to the college operations. It would also limit what kind of plants or trees could be added to the space.

OPTION 4—CAMPUS ELECTRICAL DEMAND

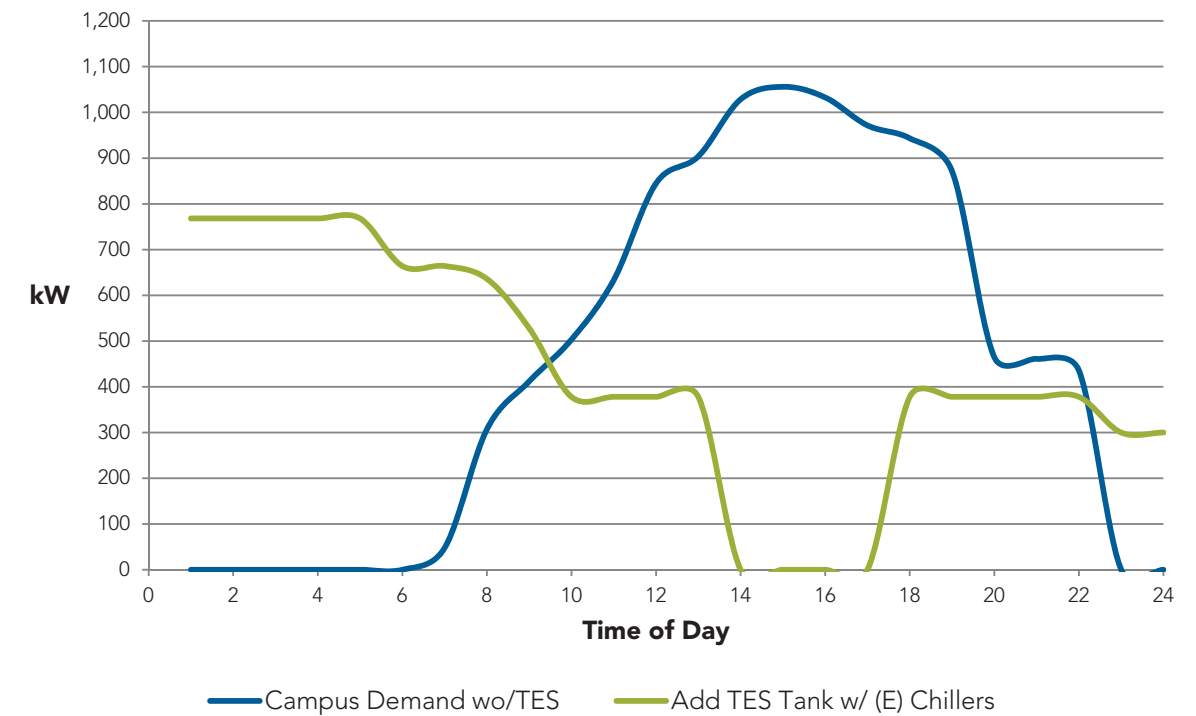

Option Four	Demand (kW)		Consumption (kWh)			Cost
	Peak	Low	Peak	Low	Base	
LADWP A3 Rates (\$)						
Peak Demand	9.00000	1				\$9
Low Peak Demand	3.00000	528.00				\$1,584
High Consumption	0.04390		1.00			\$0
Low Consumption	0.03764			4,230.00		\$159
Base Consumption	0.01755				6,104	\$107
					Total	\$1,859

Estimated costs for peak day electrical demand and consumption only. This ignores all other campus electrical usage, LADWP charges, and pumping energy. This information is for comparison of the four examples in this report, and does not represent the total energy bill of the central plant.

We feel the best possible location is at the south end of campus. Currently there are bungalows slated for demolition in this area. The master plan calls for a parking lot at this site. A concrete tank would sit approximately 3ft under the finished surface and can be constructed to handle the parking lot loads.

This location requires the addition of 12" chilled water pipes from the central plant to the tank. Part of the pipe route will be through the existing utility tunnel. Inside the tunnel the 8" chilled water lines would be replaced with the new larger size. Addition underground pipe from the tunnel to the tank location will be added. This pipe will route between Business & Journalism and math Science buildings. There is not a need to build a utility tunnel for this portion of pipe work, it can be directly buried.

Peak demand is completely reduced (ignoring pumping energy, which is common for all options). The shoulder loads or mid-peak is reduced compared to the other three options.

Option Four Advantages:

1. Smallest electrical peak demand and consumption
2. Peak demand is completely reduced (ignoring pumping energy, which is common for all options).
3. The shoulder loads or low-peak is reduced compared to the other three options.
4. Significantly reduces demand and consumption during the mid-peak hours.

5. Less wear and tear on chillers – increased life spans of chillers
6. New chiller will have long life span.
7. Existing chilled water pumps will work for this option
8. Electrical service in central plant will not be modified
9. The small ice chiller could be used to charge the water TES tank in case of failure of the large chiller.
10. Spare capacity is available due to the fact that no electrical chillers operate during peak.
11. Existing cooling towers, ice storage system and absorber remain in use.

Option Four Disadvantages:

1. High 1st cost
2. Existing 900-ton chiller must be replaced with unit to match TES tank temperature needs.
3. Large tank on site

Opinion of Probable Construction Costs

OPTION ONE - EXISTING EQUIPMENT

Description	Quantity	Unit	Cost/Unit	Cost
8" Line in East Tunnel	900	FT	225	\$202,500
900-ton CP Chiller	900	\$/ton	600	\$540,000
New Central Plant Pumps	1	LS	100,000	\$100,000
Total				\$842,500

OPTION TWO - ICE TES AT MAPA

Description	Quantity	Unit	Cost/Unit	Cost
160-ton Air Cooled Chiller	160	\$/ton	1,400	\$224,000
1600-Ton-hr Ice Tanks	1600	\$/ton-hr	160	\$256,000
Heat Exchanger	1	LS	50,000	\$50,000
Pumps	2	LS	45,000	\$90,000
6" Piping from chiller to building	400	FT	300	\$120,000
Equipment Pad / Enclosure	1	LS	80,000	\$80,000
900-ton CP Chiller	900	\$/ton	600	\$540,000
New Central Plant Pumps	1	LS	100,000	\$100,000
Electrical Service	1	LS	120,000	\$120,000
Total				\$1,580,000

OPTION THREE - REPLACE 900-TON CHILLER W/ 1400-TON

Description	Quantity	Unit	Cost/Unit	Cost
1400-ton Chiller	1400	\$/ton	600	\$840,000
1400-ton Cooling Tower	1	LS	150,000	\$150,000
Condenser and Chilled Water Pumps	1	LS	150,000	\$150,000
Electrical	1	LS	120,000	\$120,000
Structural	1	LS	200,000	\$200,000
8" Line in East Tunnel	900	FT	225	\$202,500
Total				\$1,662,500

OPTION FOUR - CHILLED WATER TES UNDER PARKING LOT

Description	Quantity	Unit	Cost/Unit	Cost
6,900 Ton-hr Underground TES Tank	6900	\$/ton-hr	156	\$1,076,400
Site Work	1	LS	300,000	\$300,000
U/G Pipe to Tank	800	LF	125	\$100,000
900-ton Variable Speed Chiller	900	\$/ton	625	\$562,500
Primary Chiller Pump	1	LS	50,000	\$50,000
New Central Plant Pumps	1	LS	100,000	\$100,000
Controls & Valves	1	LS	60,000	\$60,000
8" Line in East Tunnel	900	LF	225	\$202,500
12" CHWS/R Lines in West Tunnel	900	LF	225	\$202,500
Total				\$2,653,900

Comparing all Options

Option	Peak Demand (kW)	Peak Consumption (kWh)	Low Peak Consumption (kWh)	All Peak Consumption (kWh)	All Day Consumption (kWh)
Option 1— Current System	504	2,016	5,881	7,897	10,951
Option 2— MAPA Ice TES	295	1,138	5,598	6,736	11,391
Option 3— New VSD Chiller	450	1,800	5,546	7,346	11,684
Option 4— Additional TES Tank	0	0	4,231	4,230	10,335

All four options consume about the same energy for cooling during a peak day. Option Two was a little higher than the base case due to the air-cooled ice chiller used at MAPA. The other two Options are an improvement in energy efficiency. Options Three and Four use new high efficiency chillers and end up with the same estimated consumption.

Option Four shifts a large portion of demand from peak to base-rate, and reduces low-peak demand. This had a big impact on the cost to operate the plant. We used LADWP A3 time of use electrical rates to determine the cost differences between all four options. All options use about the same amount of kW-hrs, but each one uses the energy at different times during the day. We compared the energy cost of each option to the base case (Opt.1). The base-case has the highest energy consumption and energy costs. We used the base-case to find the payback period of the other three options.

SIMPLE PAYBACK ANALYSIS

Option	Annual Energy Cost Savings	First Cost (Construction Cost)	Payback Period (yrs)	Value at 20-yrs
One (Base Case)	\$0	\$842,500	-	-\$6,150,576
Two	\$174,513	\$1,580,000	9.05	\$1,910,265
Three	\$34,543	\$1,662,500	48.13	-\$971,638
Four	\$348,900	\$2,653,900	7.61	\$4,324,097

Option One consumes less kW-hrs than Option Two, but because of peak shavings Option Two is considerably less expensive to operate. Option Three has the highest consumption of all four scenarios. Option Four is the least expensive to operate.

We applied a multiplier to determine the annual costs of each option. This accounts for the different energy usage throughout the year. At the hottest days the energy savings are the greatest, but as the days get cooler the savings are reduced. Therefore cost savings vary with the campus cooling loads. Our multiplier averages this fact out.

Option Two has a marginally quicker payback than Option Four. But the 20-year value of Option Four is nearly double that of Two. The payback of Option Three is too long to make it a viable solution, because the life span of the chillers is shorter than the payback period.

Clearly Option Four with an underground TES tank is the best solution for Los Angeles Valley College. The energy savings and operating costs are the best. The TES tank will last the college 40+ years. The performance of the central plant will also be improved as compared the existing systems and this option does not impact the usable space on campus.

Campus Heating Loads

We determined the maximum campus heating demand based on the campus for the Master Plan. The current master plan has approximately 764,850GSF of buildings connected to the central plant. We added one 60,000GSF general-purpose building to the list at the request of the college for our calculation purposes. The completion of all buildings plus the additional building results in 824,850GSF connected to the central plant.

We determine the load for each building based on actual conditions that are known, the central plant record drawings, the Utility Master Plan, any building drawings available to us, and our experience with similar colleges.

There are 23 buildings on our list. Six are either in construction or under design at the time of this report. The loads we used for our study are shown in the table below. We also expect many of the new buildings to be highly efficient and their loads will be less than what we used.

The load from the campus varies throughout the day and time of the year. We are interested in the peak load that will be experience to determine the capacity that is needed from the central plant. The amount of time at actual peak conditions is only a small percentage of the operating hours.

We found that the total heating demand from the full build-out of the Master Plan plus one 60,000GSF building to be less than the capacity of the central plant. The total max heating load, ignoring any diversity was determined to be 20,974MBH, where the total central plant capacity was 23,050MBH. The pumping capacity of the plant was 1084GPM and we found the maximum needed flow to be 1,049GPM (again ignoring any diversity factor). Since the actual operating conditions will include some diversity the heating capacity is more than enough for the Master Plan, with additional capacity in reserve.

Delivery of the Heating Hot Water to the Campus

We determined the required flow rate of heating hot water needed to each building. When we looked at the building lateral supply lines we did so without applying a diversity factor. Diversity was avoided here because any one building can be at peak demand and the piping must be sized to deliver this rate. Currently the College uses a temperature differential of 40°F for heating hot water. There is not a plan to change this.

We found the heating hot water piping in the east tunnel to be undersized for the expected loads. We found delivery velocities exceeding the recommended allowances. This would hinder the ability of the plant to heat the buildings and cause the pumps to use more energy than needed. We recommend the loop piping in this tunnel be increased to 6".

We found that the laterals for the LLRC Library and Community Workforce Development Center to be under sized. We suspect the designers of the Library found the same issue and made corrections to the line size. The CWDC is proposed and not yet designed so that this issue can be resolved prior to construction.

Building	GSF	Design Peak Loads (MBH)	Master Plan (MBH)	Labeled on Master Plan	GPM @ 40ΔF
Foreign Language	16,130	358	361	3	18
Engineering	24,145	537	578	6	27
South Gym	45,200	1,004	1,060	7	50
Liberal Arts (Business & Journalism)	20,660	459	554	19	23
Music Building & Recital Hall	16,441	365	410	11	18
Art	18,965	421	337	48	21
EMS/New Environment Center	22,590	502	554	8	25
Math	19,611	436	482	50	22
Planetarium	2,616	58	0	51	3
Behavioral Science	13,700	304	337	52	15
Humanities	19,400	431	482	53	22
Motion Picture/ TV Studio	4,700	104	410	54	5
Business Technology Center (Campus Center)	83,553	1,857	2,020	56	93
Allied Health Science	80,767	4,038	6,280	76	202
North Gym & DSPS Gym	37,963	844	900	67	42
Student Services Center & Annex	40,186	893	1,000	102	45
Library & Academic Resource Center	92,922	2,065	1,700	68	103
Media Arts/Performance Arts Center (MAPA)	62,000	1,378	1,300	V-11	69
Athletic Training Facility	18,000	400	400	V-13	20
Mcsc	25,000	556	556	V-16	28
Cwdc & Administration	70,000	1,556	1,556	V-12	78
Monarch (Student Union)	48,300	1,073	1,073	V-22	54
Instructional Building (Future)	60,000	1,333	1,333	V-XX	67
Existing Loads		12,613	15,765	-	
Total	842,849	20,974	23,683	-	1,049
Diversified Peak Loads	80%	16,779	18,946	-	839
				Max GPM	1,049
				Design GPM	839

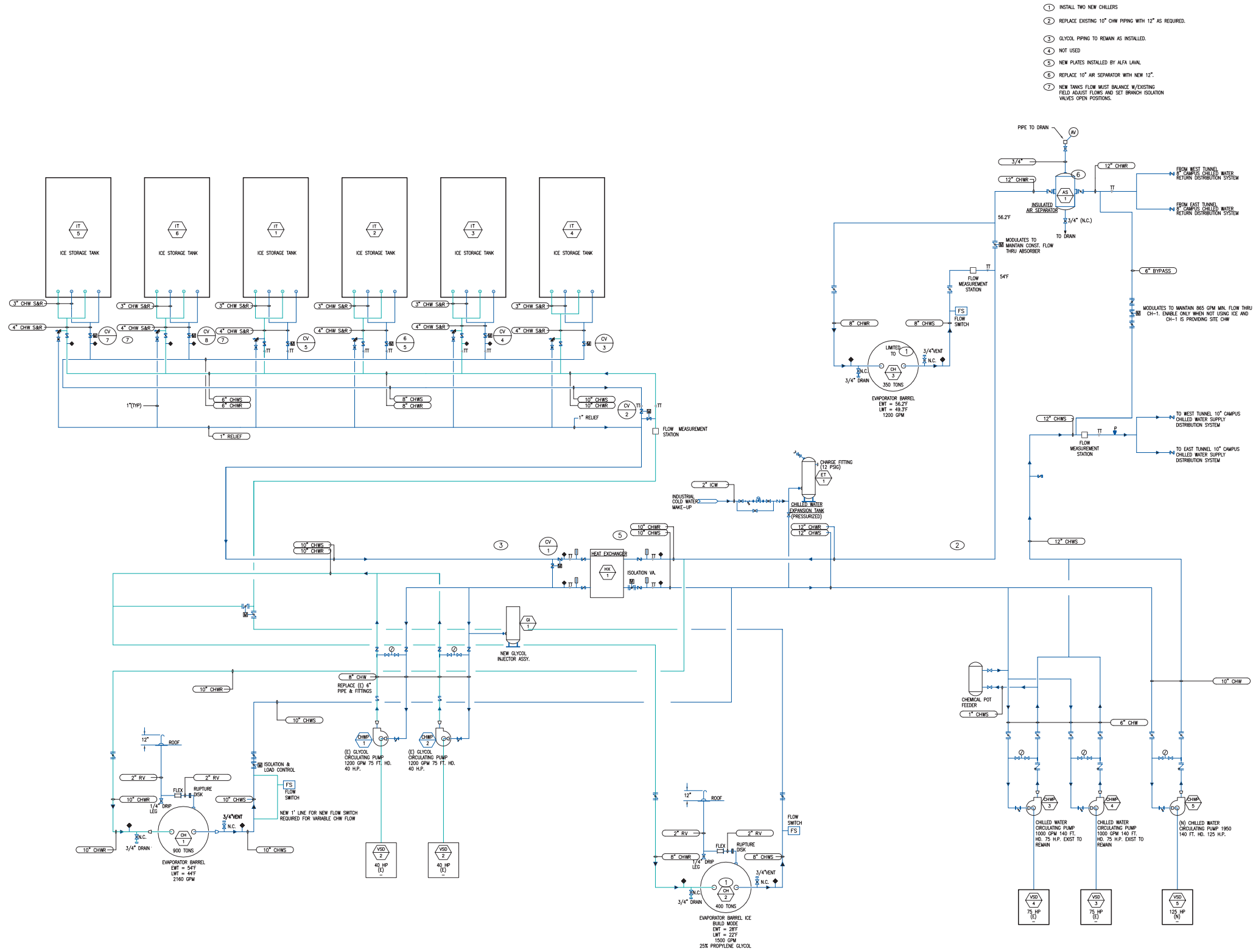

- 1 INSTALL TWO NEW CHILLERS
- 2 REPLACE EXISTING 10\"/>
- 3 GLYCOL PIPING TO REMAIN AS INSTALLED.
- 4 NOT USED
- 5 NEW PLATES INSTALLED BY ALFA LAVAL.
- 6 REPLACE 10\"/>
- 7 NEW TANKS FLOW MUST BALANCE W/EXISTING FIELD ADJUST FLOWS AND SET BRANCH ISOLATION VALVES OPEN POSITIONS.

M400.0—Central Plant Chilled Water Flow Schematic

- ① NEW COOLING TOWER
- ② NEW CONDENSER WATER PIPING
- ③ EXISTING PUMPS TO REMAIN
- ④ PROVIDE DOLPHIN WATER TREATMENT WITH FLANGE CONNECTION
- ⑤ NEW VSD FURNISHED BY CHEVRON WIRE AND CONDUIT UNDER DIV. 16
- ⑥ NEW SKID MOUNTED CENTRIFUGAL SEPARATOR
- ⑦ NEW CONDENSER WATER PUMPS

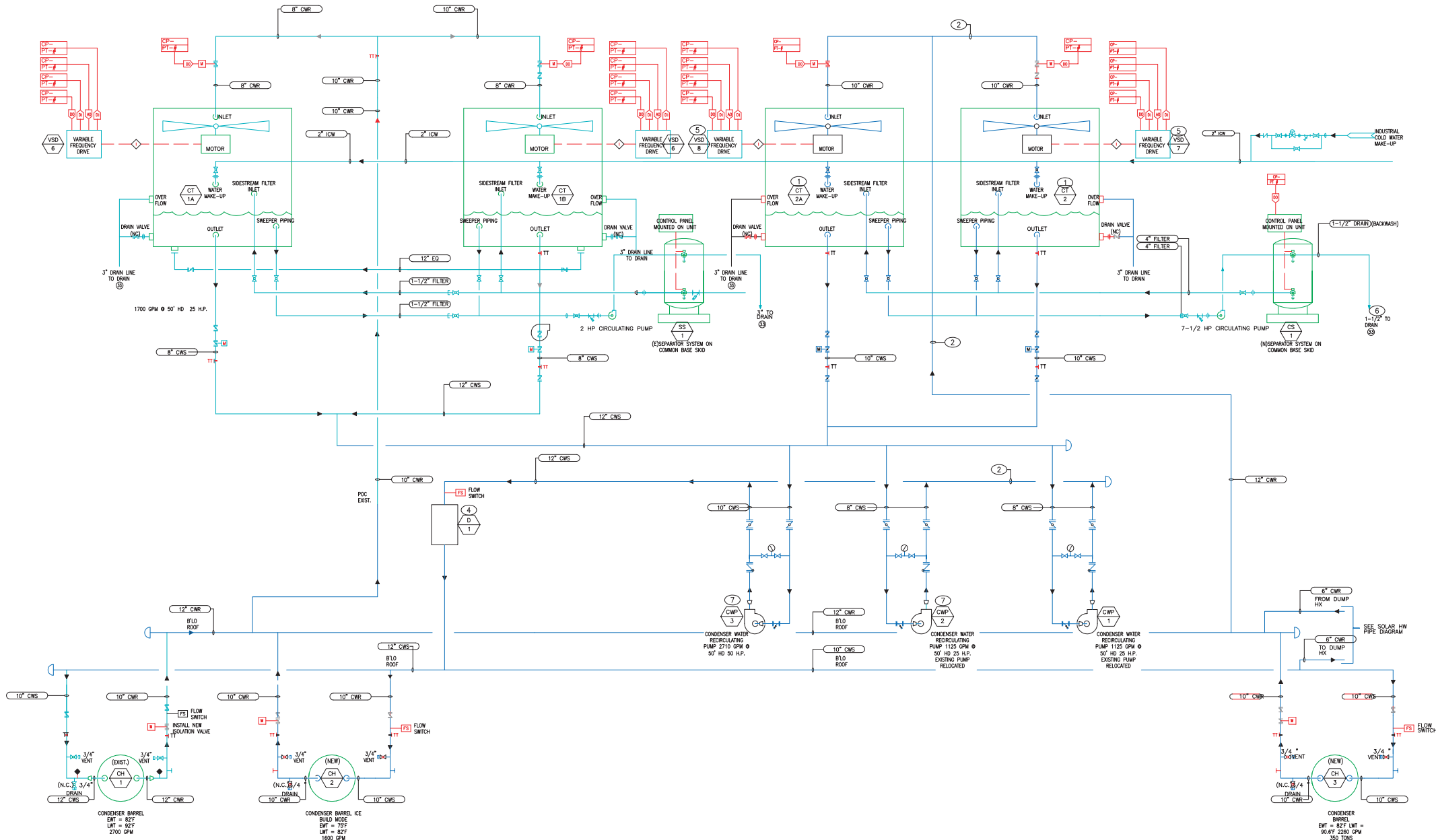

M400.1—Central Plant Condenser Water Flow Schematic

