

Los Angeles Mission College **CATALOG 2016-2017**

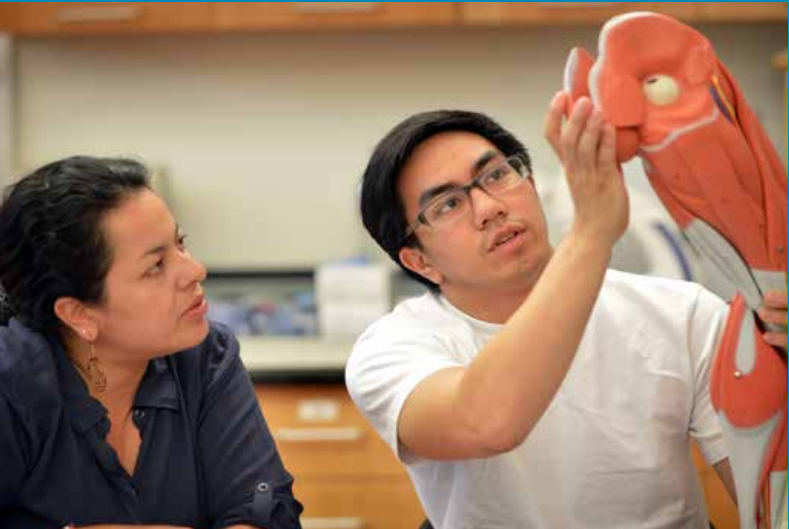

WELCOME

to Los Angeles Mission College



Surrounded by mountain vistas, Los Angeles Mission College (LAMC) is located in the beautiful northeast San Fernando Valley. L.A. Mission College is known as an institution of higher learning that is flexible, adaptive and responsive to the changing needs of our students and surrounding communities. With a student body of 12,000 and the strong support of the community, LAMC is the leading source of post-secondary education and workforce training.

LAMC is working together to build and strengthen our communities. We are proud to serve students across the northeast San Fernando and beyond.

I encourage you to take time to review this catalog as it contains information on curriculum offerings, course descriptions, student support services, and serves as a reference during your journey at L.A. Mission College. LAMC offers an array of programs of study that lead to transfer to a four-year higher education institution, associate degrees, career and technical certificates. Classes are taught by highly qualified faculty committed to providing opportunities that will help you succeed academically and secure an exciting career.

Our Mission Is



As you start this academic year, get involved in student life and governance by participating in co-curricular or extra-curricular activities. Consider trying out for our softball, baseball, or volleyball teams; join our Theater Arts program; participate in the Associated Students Organization or honors club. Check out our website at www.lamission.edu – we’re just a click away.

I am proud to say we have one of the most beautiful community college campuses. The Culinary Arts Institute and Center for Math & Science buildings have been named “the best hospitality and sustainability buildings” by the San Fernando Business Journal and the Design Build Institute of Architects. I invite you to stop by and take a tour of the campus and talk with faculty, students and staff – as they are always ready to meet you.

Again, welcome to Los Angeles Mission College. I know you will find your experience at LAMC to be rewarding and exciting.

Very truly yours,

*Monte E. Perez, PhD
President, Los Angeles Mission College*

Your Success



LOS ANGELES COMMUNITY COLLEGE DISTRICT

CITY / EAST / HARBOR / MISSION / PIERCE / SOUTHWEST / TRADE-TECHNICAL / VALLEY / WEST

BOARD OF TRUSTEES

Scott J. Svonkin
President

Mike Eng
Vice President

Mike Fong

Andra Hoffman

Sydney K. Kamlager

Ernest H. Moreno

Nancy Pearlman

Milo Anderson
Student Trustee

DISTRICT ADMINISTRATION

Dr. Francisco C. Rodriguez
Chancellor

Dr. Adriana D. Barrera
Deputy Chancellor

Dr. Felicito Cajayon
*Vice Chancellor for Economic
& Workforce Development*

Dr. Ryan M. Cornner
*Vice Chancellor for Educational
Programs & Institutional Effectiveness*

Kevin D. Jeter
Interim General Counsel

Dr. Robert B. Miller
*Vice Chancellor of Finance and Resource
Development*

James D. O'Reilly
Chief Facilities Executive

Dr. Albert J. Roman
Vice Chancellor for Human Resources

MISSION COLLEGE ADMINISTRATION

Monte E. Perez, PhD
President

Michael K. Allen, JD
Vice President, Academic Affairs

Christopher Villa, EdD
Vice President, Student Services

Daniel G. Villanueva
Vice President, Administrative Services

Madelline Hernandez
Dean, Academic Affairs

Isabelle Saber
Dean, Academic Affairs

Darlene Montes
Dean, Academic Affairs

Sarah Master, PhD
Dean, Institutional Effectiveness

Ludi Villegas-Vidal
Dean, Student Services

Carlos R. Gonzales
Dean, Student Success

Larry Resendez, PsyD
Associate Dean, DSP&S

Vacant
Associate Dean, CTE & Workforce Development

ACADEMIC CALENDAR 2016-2017

FALL 2016

Assessment and Orientation	Year Round
Priority Registration.....	May 2–4, 2016
Continuing Student Registration.....	May 5 – June 5, 2016
New & Returning Student Registration.....	June 6 – Aug 28, 2016
Residency Determination Date	Aug 28, 2016
DAY AND EVENING CLASSES BEGIN.....	Aug 29, 2016
Saturday Classes Begin	Sep 3, 2016
Last Day to Add.....	Sep 9, 2016
Last Day to Drop (No Penalty).....	Sep 11, 2016
Last Day to Drop with “W”	Nov 20, 2016
Last Day of Instruction	Dec 10, 2016
FINAL EXAMS	Dec 12–7, 2016

HOLIDAYS (College CLOSED)

Labor Day	Sep 5, 2016
Veteran’s Day	Nov 11, 2016
Thanksgiving.....	Nov 24–27, 2016
Holiday Break.....	Dec 23, 2016 – Jan 2, 2017
Martin Luther King Birthday	Jan 16, 2017

SPRING 2017

Assessment and Orientation	Year Round
Priority Registration.....	Nov 14 – Nov 16, 2016
Continuing Student Registration.....	Nov 17 – Dec 18, 2016
New & Returning Student Registration.....	Dec 19, 2016 – Feb 5, 2017
Residency Determination Date	Feb 5, 2017
DAY AND EVENING CLASSES BEGIN.....	Feb 6, 2017
Saturday Classes Begin	Feb 11, 2017
Last Day to Add.....	Feb 20, 2017
Last Day to Drop (No Penalty).....	Feb 20, 2017
Last Day to Drop with “W”	May 7, 2017
Last Day of Instruction	May 27, 2017
FINAL EXAMS	May 30 – June 5, 2017

HOLIDAYS (College CLOSED)

President’s Day	Feb 17–20, 2017
Cesar Chavez Birthday.....	Mar 31, 2017
Spring Break.....	Apr 1–7, 2017
Non-Instruction Day (College Closed).....	Apr 16, 2017
Memorial Day.....	May 29, 2017
Independence Day	July 4, 2017

NOTE: FOR ADDITIONAL INFORMATION PLEASE SEE THE SCHEDULE OF CLASSES.

FOR THOSE WITH DISABILITIES, ALTERNATE FORMATS OF THIS SCHEDULE ARE AVAILABLE BY CALLING 818.833.3313



Los Angeles Mission College is a tax-supported educational institution which offers post-high school opportunities for men and women and is administered by Los Angeles Community College District.

13356 Eldridge Avenue
 Sylmar, California 91342-3245
 Phone: 818.364.7600
 Telephone Device for the Deaf: 818.364.7861
www.lamission.edu

Los Angeles Mission College (LAMC) is accredited by the Accrediting Commission for Community and Junior Colleges (ACCJC) of the Western Association of Schools and Colleges, (10 Commercial Boulevard, Suite 204, Novato, California 94949; 415.506.0238), an institutional accrediting body recognized by the Commission on Recognition of Postsecondary Accreditation and United States Department of Education.

Telephone Extensions

All campus phone numbers are direct lines unless otherwise noted.

To contact a direct on-campus number from an off-campus phone, call 818.364.xxxx.

OFFICE	LOCATION	EXTENSION	OFFICE	LOCATION	EXTENSION	OFFICE	LOCATION	EXTENSION
A			F			R		
Academic Affairs	INST	7632	Faculty Offices			Records (Metropolitan College)	CMPS	7773
Academic Senate	INST	7876	Arts, Media, Performance	INST	7680	Recruitment	INST	7779
Administrative Services	CMPS	7780	Business & Law	INST	7680	S		
Admissions	INST	818.833.3322	Chicano Studies	INST	7793	Sheriff	BUNG	7843
Articulation	INST	7618	ESL, DevCom, Learning Skills	INST	7632	Student Activities	CMPC	818.364.7600 x7120
Assessment	CMPC	7613	English, Communication	INST	7680	Student Services	LRC	7766
Associated Students Organization (ASO)	CMPC	818.364.7600 x7120	Foreign Languages	INST	7680	Student Support Services (TRIO)	CMPC	7821
Athletic Department	HFAC	7727	Health, Kinesiology, Athletics	HFAC	7727	T		
B			Life Sciences	CMS	7793	TDD LINE (Information)	INST	818.364.7895
Bookstore (Student Store)	CAI	7798	Mathematics, CoSci, Engr	CMS	7894	Transcripts	INST	7659
Business Office	CMPS	818.833.3323 818.364.7110	Physical Sciences	CMS	7793	Transfer Center	CMPS	7827
C			Professional Studies	INST	7756	Tutoring	LRC	7756
CalWORKs	CMPC	7760	Social Sciences	CMS	7793	V		
Center for Child Development Studies	CCDS	7632	Financial Aid	INST	7648	Veterans	CMPC	7864
Citizenship & GED Center	BUNG	818.364.7774	Foster/Kinship Care Education (FKCE)	CMPC	818.364.7600 x7135	W		
Credit Clerk	INST	7663	I			Workforce Development/ Grants Office	LRC	7760
Counseling Department	INST	7655	Instructional Television (ITV)	CMPC	818.833.3594			
D			International Students	CMPC	818.364.7741			
Disabled Students Programs & Services (DSPS)	INST	7732	L					
TDD Line (Disabled Students)	INST	818.364.7861	Learning Center (LRC)	LRC	7756			
E			Library	LRC	818.364.7600 x7106			
Emergency Services	BUNG	7843	Lost & Found	BUNG	7843			
Extended Opportunities Programs & Services (EOPS)	INST	7645	M					
			Matriculation	INST	7866			
			Multimedia	LRC	7680			
			Music	CAC	7680			
			P					
			President's Office	CMPS	818.364.7795			

BUNG	Bungalows
CAC	Cultural Arts Classes
CCDS	Center for Child Development Studies
CMPC	Campus Center Building
CMPS	Campus Services Building
CSB	Collaborative Studies Building
CUL	Culinary Arts Building
HFAC	Health, Fitness & Athletics Complex
INST	Instructional Building
LRC	Library/Learning Resources Center Building

For Off-Campus locations, see page 185.

Table of Contents

Welcome to Los Angeles Mission College

College President’s Letter to Students	Inside cover
Los Angeles Community College District.....	2
Board of Trustees District Administration College Administration	
Accreditation Statement.....	3
College Address	3
Telephone Extensions for College.....	4

GENERAL INFORMATION 8

College History
College Mission Statement
Vision Values Theme
College Goals
Educational Philosophy
Institutional Learning Outcomes
Functions of the Community College
Academic Senate Faculty Ethics Statement
Code of Conduct Statement
College Advisory Committees
College Facilities & Locations
Publications

ADMISSIONS & REGISTRATION PROCEDURES 14

Admissions Eligibility
Matriculation
Residency Requirements
International Student Admissions
Fees & Costs
College & High School
Auditing Classes
Cancellation of Classes
Change of Program
Day & Extended Day Classes (Hours)
Full & Part-Time Students
Open Enrollment
Suggested Study Load

STUDENT INFORMATION 24

Student Services
Counseling Office Child Development Center
Cooperative Agencies Resources for Education (CARE)
Disabled Students Programs & Services (DSPS)
Extended Opportunity Program & Services (EOPS)
Intercollegiate Athletics Transfer Center Veteran Affairs Program

Financial Aid

Eligibility How to Apply Grants Loans Scholarships
Satisfactory Academic Progress Policy

Special Programs

Non-Credit Program
Instructional Television (ITV)
International Education Program - Study Abroad

Student Activities

Associated Students Organization (ASO)
Student Clubs & Organizations Student Trustee Colors & Theme

Honors Program

Standards of Student Conduct & Disciplinary Action

Academic Affairs

The Learning Center – Tutorial Services
Library – An Instructional Service

STEM Program

Workforce Development & Educational Programs

California Work Opportunity & Responsibility to Kids (CalWORKs)
California Early Childhood Mentor Program
Career Technical Education (CTE)
SB 1070 Career Technical Pathways Program
Child Development Training Consortium
Family Child Care Homes Education Network (FCCHEN)
Foster/Kinship Care Education (FKCE)
Guardian Scholars Program
LA HI-TECH California Career Pathways Trust
Linked Learning: A Bridge to College and Career Success
Los Angeles Healthcare Competency-to-Career Consortium (LAH3C)
Partnering For Safety & Permanence - Model Approach to Partnerships in Parenting (PS MAPP)
San Fernando Valley Scholars Network
TRIO/Student Support Services (SSS)

Business & Fiscal Services

Eagles’ Landing Student Store
Student Parking Regulations
College Sheriff’s Department
Lost & Found

DISTRICT INFORMATION 44

Academic Standards

Academic Honors Academic Probation & Dismissal
Attendance Course Repetition & Activity Repetition
Concurrent Enrollment Course Credit Information
Final Examinations Grades Transcripts

District Policies

Students’ Statements Instructional Materials
Withdrawal Three Repeat Rule Access to Records
Family Educational Rights & Privacy Act (FERPA) Notification
Student Right-to-Know Disclosure Student Grievance Procedure
Recording Devices in the Classroom Compliance Officer
Standards of Student Conduct & Disciplinary Action
Policy on Illegal File Sharing
Non-Discrimination Policy Sexual Assault
Sexual Harassment Policy Ombudsperson’s Role
Diversity Program Drug-Free Environment Smoking Policy
Campus Crime Report Campus Security

GRADUATION INFORMATION 70

Graduation Requirements

Associate in Arts / Associate in Science Degree Requirements
Graduation / Transfer Plans Certificate Programs
Degrees & Certificates

TRANSFER INFORMATION 77

Intersegmental General Education Transfer Curriculum
California State Universities University of California
Independent California Colleges & Universities
Associate Degree for Transfer

Table of Contents

DISCIPLINES, EDUCATIONAL PROGRAMS & COURSE DESCRIPTIONS	83	CHEMISTRY	96	CULINARY ARTS	116
ACCOUNTING	84	CHICANO STUDIES	97	• Associate in Arts: Restaurant Management	
• Associate in Arts: Accounting		• Associate in Arts: Chicano Studies		• Certificate: Culinary Arts	
ADMINISTRATION OF JUSTICE	85	CHILD DEVELOPMENT	100	• Certificate: Professional Baking & Patisserie	
• Associate in Science: Administration of Justice		• Certificate of Accomplishment: Child Development		• Certificate: Restaurant Management	
• Associate in Science for Transfer: Administration of Justice		• Certificate of Accomplishment: Child Development in Administration		• Certificate of Accomplishment: Baking I	
• Certificate of Achievement: Probation/Correction Officer Candidate		• Certificate of Accomplishment: Family Child Care		• Certificate of Accomplishment: Baking II	
• Certificate of Accomplishment: Basic Police Academy Preparation		• Certificate: Preschool		• Certificate of Accomplishment: Culinary Specialist I	
• Certificate of Accomplishment: Crime Scene Technology		• Certificate: Bilingual/Bicultural Preschool		• Certificate of Accomplishment: Culinary Specialist II	
AFRICAN-AMERICAN STUDIES	87	• Certificate: Infant & Toddler		• Certificate of Accomplishment: Restaurant Management	
ALLIED HEALTH	88	• Certificate: School-Age Child Care		DANCE STUDIES	123
ANATOMY	88	• Certificate: Family Child Care		DANCE TECHNIQUES	123
ANTHROPOLOGY	88	• Certificate: Special Needs		DEVELOPMENTAL COMMUNICATIONS	124
ART	88	• Associate in Arts: Child Development		EARTH SCIENCE	124
• Associate in Arts: Art		• Associate in Science for Transfer: Early Childhood Ed		ECONOMICS	125
• Associate in Arts: Art, Gallery and Museum Studies		CINEMA	106	EDUCATION	125
• Associate in Arts: Painting		COMMUNICATION STUDIES (formerly Speech)	107	ENGLISH	126
• Associate in Arts for Transfer: Studio Arts		• Associate in Arts for Transfer: Communication Studies		• Associate in Arts: English	
ART HISTORY	92	COMPUTER APPLICATIONS & OFFICE TECHNOLOGIES	108	• Associate in Arts for Transfer: English	
ASTRONOMY	92	• Associate in Arts: Computer Applications & Office Technologies		ENGLISH AS A SECOND LANGUAGE	128
BAKING, PROFESSIONAL	92	• Certificate of Accomplishment: Communications		ESL CIVICS	131
BASIC SKILLS	93	• Certificate of Accomplishment: Computer Applications		ENVIRONMENTAL SCIENCE	131
BIOLOGY	93	• Certificate of Accomplishment: Office Assistant		FAMILY & CONSUMER STUDIES	131
• Associate in Science: Biology		COMPUTER SCIENCE INFORMATION TECHNOLOGY ..	111	• Associate in Arts: Family Studies	
• Associate in Science for Transfer: Biology		• Associate in Arts: Computer Science		• Associate in Arts: Food & Nutrition	
BUSINESS	95	• Associate in Arts: Computer Science: Business Emphasis		• Associate in Arts: Gerontology	
• Associate in Arts: Business Administration		• Certificate: Microcomputer Applications Management		• Certificate: Gerontology	
• Associate in Science for Transfer: Business Administration		• Certificate: Microcomputer Programming		• Certificate of Accomplishment: Introduction to Hospitality	
		• Certificate of Accomplishment: Microcomputer Applications		FINANCE	134
		• Certificate of Accomplishment: Cyber Security Associate		• Associate in Arts: Finance	
		COUNSELING	113	FRENCH	135

GENERAL STUDIES	135	LIBRARY SCIENCE	149	PSYCHOLOGY	166
• Associate in Arts: General Studies		LINGUISTICS	149	• Associate in Arts: Psychology	
GEOGRAPHY	137	MANAGEMENT	150	• Associate in Arts for Transfer: Psychology	
GEOLOGY	137	• Associate in Arts: Management		SOCIOLOGY	168
HEALTH	137	• Certificate: Retail Management		• Associate in Arts for Transfer: Sociology	
HEALTH OCCUPATIONS	138	MARKETING	151	SPANISH	169
• Certificate of Accomplishment: Health Occupations Fundamentals		• Associate in Arts: Marketing		• Associate in Arts: Spanish	
HEALTH SCIENCE	138	MATHEMATICS	152	• Associate in Arts for Transfer: Spanish	
• Associate in Science: Health Science		• Associate in Arts: Mathematics		TECHNICAL STAGE PRODUCTION	170
HISTORY	139	• Associate in Science for Transfer: Mathematics		THEATER	171
HUMANITIES	140	MICROBIOLOGY	155		
• Associate in Arts: Humanities		MULTIMEDIA STUDIES	156	Faculty	173
INTERIOR DESIGN	141	• Associate in Arts: Multimedia Studies		Glossary of Terms	178
• Associate in Arts: Interior Design		• Certificate: Multimedia Studies		Index	181
• Certificate: Interior Design		• Certificate of Accomplishment: Multimedia Studies		Mission College Buildings & Classrooms	184
• Certificate of Accomplishment: Introduction to Interior Design		MUSIC	159	Mission College & Offsite Locations	190
• Certificate of Accomplishment: Introduction to Space Planning		NURSING	160	Student Education Planner	192
• Certificate of Accomplishment: Technology and Interior Design		• Certificate of Accomplishment: Certified Nursing Assistant and Home Health Aide		Campus Map	Inside back cover
ITALIAN	144	OCEANOGRAPHY	161		
JOURNALISM	144	PHARMACY TECHNICIAN	161		
KINESIOLOGY (formerly Physical Education)	144	PHILOSOPHY	162		
KINESIOLOGY MAJOR	147	• Associate in Arts for Transfer: Philosophy			
LAW	147	PHOTOGRAPHY	162		
• Associate in Arts: Legal Assisting (Paralegal)		PHYSICAL SCIENCE	163		
LEARNING SKILLS	149	• Associate in Arts: Physical Science			
LIBERAL STUDIES	149	PHYSICS	164		
• Associate in Arts: Multiple Subject Teacher Prep		PHYSIOLOGY	164		
		POLITICAL SCIENCE	165		
		• Associate in Arts for Transfer: Political Science			
		PORTUGUESE	166		

General Information

Los Angeles Mission College

is currently located on 33 acres in the community of Sylmar. The College was established in 1975 as the ninth college in the Los Angeles Community College District and the 100th community college in California. For its first 16 years the College offered classes in scattered storefronts and leased facilities throughout the city of San Fernando and surrounding communities.

In 1991, the new permanent campus was completed on a 22-acre site in Sylmar and the College experienced a surge in enrollments and a resulting higher visibility in the community. In 2007 the College acquired 11 additional acres, which expanded its footprint to its existing size. From humble storefront beginnings in 1975 to today's modern campus, the College has opened the doors to higher education for generations of students. From the beginning, the College has sought to unleash the potential of the community through innovative programs encouraging academic and personal growth.

During its 37-year existence, over 234,000 students have chosen to pursue their education at the College. Los Angeles Mission College remains the only institution of higher learning primarily serving the Northeast San Fernando Valley.



In 2001, 2003 and again in 2008, voters approved three separate bond measures – Proposition A, Proposition AA, and Measure J designed to help the nine Los Angeles Community College District campuses expand and improve aging facilities. The College has completed the construction of the parking structure, totaling 1200 spaces, with a power-producing solar panel array on the fourth level; a Center for Child Development Studies building providing a combination of services for the community and academic training for students who wish to become professionals in the field of Early Childhood Education; a Health, Fitness and Athletics Complex featuring modern equipment and energy saving building construction; a Culinary Arts Institute and Eagles' Landing Student Store consisting of classrooms and laboratories serving the culinary arts department, campus dining facilities, and the student store; and the Center for Math & Science building featuring state-of-the-art classrooms and science laboratories provided with research equipment and furnishing. In addition, construction of the Media Arts Center is approximately 30 percent completed. The College supports environmental concerns by incorporating the highest standards in green building design principles for renovation and new building projects.

In fall 2013, the College served nearly 10,200 students and enrollment remains steady.

Current projects include the Media Arts building which will provide the campus with performance accommodations with a 99-seat theater offering our students experience in current technological advancements in sound and performance delivery.

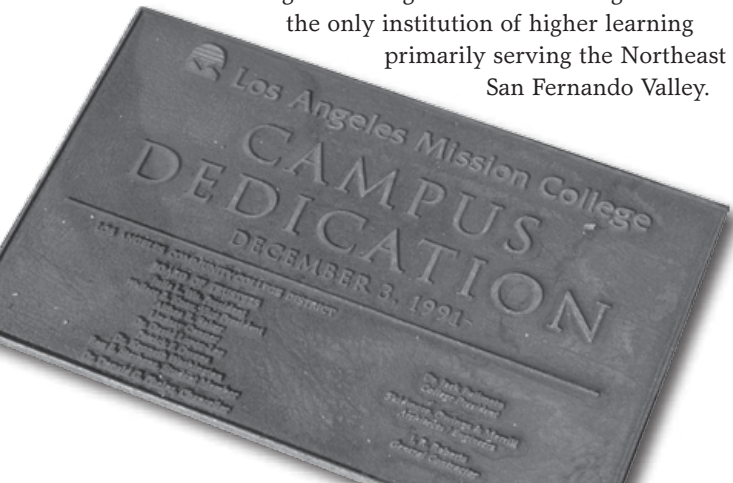

COLLEGE MISSION STATEMENT

Los Angeles Mission College is committed to the success of its students. The College, which awards associate degrees and certificates, provides accessible, affordable, high quality learning opportunities in a culturally and intellectually supportive environment by:

- Providing Services and programs in basic skills, general education, career and technical education, and for transfer;
- Educating students to become critical thinkers and lifelong learners;
- Ensuring that all programs and services are continuously evaluated and improved to support students learning and achievement;
- Making traditional and distance education learning opportunities available to enhance the health and wellness of the diverse communities it serves.

VISION

Los Angeles Mission College is committed to maintaining high academic standards, promoting student success, and creating opportunities for life-long learning. The college will inspire students to become informed, active citizens who recognize and appreciate the common humanity of all people through diverse curricula, and through cultural, academic, and artistic events. The college will practice an honest, collegial, and inclusive decision-making process that respects the diversity and interdependence of the college, student body, and community LAMC is privileged to serve.

LAMC VALUES

1. The pursuit of excellence in all our endeavors
2. Intellectual curiosity and the desire to learn
3. A global vision that understands and appreciates the common goals and purposes of all people
4. An appreciation of diversity that nourishes mutual respect and solidarity
5. Integrity and collegiality in all our interactions
6. Service to the campus and the local community

THEME

“Our Mission Is Your Success”

In pursuit of this mission, we endeavor to

- Promote equal opportunity for participation;
- Maintain appropriate standards for academic achievement;
- Provide an educational environment which meets the needs of students with varied learning skills;
- Provide support services which contribute to instructional effectiveness and student success;
- Affirm the importance of multicultural, international and intercultural collegiate experiences that foster individual and group understanding;
- Manage effectively educational and financial resources.

COLLEGE GOALS

1. Expand access to educational programs and services
2. Refine institutional governance and planning processes and procedures to enhance the delivery of programs and services
3. Improve Quality of Educational Programs & Services
4. Maintain Fiscal Stability and encourage a greater focus on revenue enhancement
5. Use and allocation of innovative technology to improve institutional effectiveness and efficiency
6. Increase community responsiveness and expand business, community and civic partnerships

EDUCATIONAL PHILOSOPHY

The Los Angeles Community Colleges affirm the principle that individuals should have opportunities to develop to their full potential. To that end, our main responsibility is to students and to the

provision of education, which benefits students and enables them to contribute to society.

Our colleges, therefore, should be accessible to all individuals who have the capacity and motivation to profit from higher education. Curricula and services of our colleges should provide means for fulfilling the promise of open access.

INSTITUTIONAL LEARNING OUTCOMES

We recognize the necessity to adapt to the changing educational needs of the Los Angeles Community Colleges communities and to the growing diversity among students. The quality of the educational experience is to be judged by its value to students and communities, not merely by quantitative appeal. We further recognize that academic freedom is essential to excellence in education.

The Los Angeles Mission College mission, vision and philosophy are embodied in the College's Institutional Learning Outcomes. The faculty believes that students who complete a specified course of study at the college should be able to demonstrate competency in a broad range of abilities. In support of this belief, the college's Academic Senate approved the following Institutional Learning Outcomes:

Written & Oral Communication

Students will demonstrate the interactive nature of communication involving speaking, writing, listening and reading. Evidence of competency will be the student's ability to make a clear, well-organized verbal presentation employing appropriate evidence to support the arguments or conclusions and to write a clear, well-organized paper using documentation and quantitative tools when appropriate.

General Information

Information Competency

Students will demonstrate information competency by combining aspects of library literacy, research methods and technological literacy. Information competency includes consideration of ethical and legal implications of information and requires the application of both critical thinking and communication skills. Evidence will be the ability to find, evaluate, use and communicate information in all its various formats.

Problem Solving

Students will demonstrate the ability to solve problems by examining, selecting, using and evaluating various approaches to developing solutions. Evidence of competency will be the ability to observe and draw reasonable inferences from observations, distinguish between relevant and irrelevant data, define problems, analyze the structure of discipline- or profession-based problem-solving frameworks and to use such frameworks and strategies to develop solutions.

Quantitative Reasoning

Students will demonstrate quantitative reasoning by identifying relevant data (numerical information in mathematical or other contexts), selecting or developing models appropriate to the problem which represents the data (organized representations of numerical information, e.g., equations, tables, graphs), obtaining and describing results and drawing inferences from data. Evidence of competency will be the ability to extract appropriate data from a problem, to arrange data into tables and graphs or to select or set up an equation or formula, to obtain correct results, to describe trends and features in those results and to make predictions or estimates while drawing qualitative conclusions about the original situation.

Aesthetic Responsiveness

Students will demonstrate aesthetic responsiveness by taking a position on and communicating the merits of great works of the human imagination such as art, music, literature, theater and dance and how those works reflect human values. Evidence of competency will be effective written or oral communications that articulate a response to works of art, explain how personal and formal factors shape that response and connect works of art to broader contexts.

Ethics & Values

Students will demonstrate facility in making value judgments and ethical decisions by analyzing and formulating the value foundation/framework of a specific area of knowledge in its theory and practice or in a professional context. Evidence of competency will be the ability to distinguish between factual and value claims, to discern and analyze values in the arts, humanities, and sciences and to engage in reasoned ethical decision-making.

Global Awareness

Students will demonstrate global perspectives by generating theoretical and pragmatic approaches to global problems within a disciplinary or professional context. Evidence of competency will be the ability to analyze issues from multiple perspectives, to articulate understanding of interconnected local and global issues, and to apply frameworks in formulating a response to those issues.

FUNCTIONS OF THE COMMUNITY COLLEGE

To accomplish the educational philosophy and mission of the Los Angeles Community Colleges, Los Angeles Mission College offers the following types of educational programs.

Transfer

A college transfer program that enables the student who completes 60 transferable units of study to continue upper-division work at accredited four-year colleges and universities through careful and continuous articulation with accredited collegiate institutions and high schools.

Career Technical Education (CTE)

An occupational education program planned to offer the student basic business, technical and professional curricula to develop skills that can lead to employment, job advancement, certification, or the Associate Degree.

General Education

A program of general education comprised of Associate Degree programs and other planned experiences that develop knowledge, skills and attitudes necessary for the student to be effective as a person, a family member, a worker and a citizen, thereby enhancing the quality of life for the individual and the society at large.

Transitional Education

A program of remedial and basic skills education for students needing preparation for community college-level courses and programs and English as a Second Language instruction for immigrants, foreign students and other students with limited English proficiency.

Counseling

A program incorporating academic and career, counseling assisting in matters of educational planning, admissions, financial aid, and other student services.

Continuing Education

A program of continuing education comprised of graded and ungraded classes that supplement formal full-time college attendance to provide opportunities for personal and occupational competence.

Community Education

A program of community services offered to meet the needs of the community for short-term, not-for-credit fee based classes to improve the quality of life by providing lifelong learning opportunities to members of the community. College credit is not given for these classes. There are no transcripts or grades.

Joint Programs

Joint programs with business, industry, labor, education, government and other institutions, which are of mutual benefit to sponsoring institutions. These programs enhance the educational opportunities of program participants and advance the mission and functions of the District.

ACADEMIC SENATE FACULTY ET EMC /S /MCID 7 BDC HICS STATEMENT

1. *Community college faculty members*, guided by a devout conviction of the worth and dignity of the advancement of knowledge, recognize the special responsibilities placed upon them. Their primary responsibility to their students is to seek and to state the truth as they see it. To this end, faculty members devote their energies to developing and improving their scholarly competence. They accept the obligation to exercise critical self-discipline and judgment in using, extending, and transmitting knowledge. They practice intellectual honesty. Although faculty members may follow subsidiary interests, these interests must never seriously hamper or compromise their freedom of inquiry.

2. *As teachers*, faculty members foster the free pursuit of learning in their students. They hold before them the best scholarly standards of their discipline. Faculty members demonstrate respect for the student as an individual and adhere to their proper role as intellectual guides and counselors. Faculty members make every reasonable effort to foster honest academic conduct and to ensure that evaluation of students reflects their true merit. They respect the confidential nature of the relationship between faculty member and student. They avoid any exploitation of students for private advantage and acknowledge significant assistance from them. They protect the academic freedom of students. Faculty members are obligated to ensure that students conduct themselves according to principles of academic honesty specified in the Standards of Student Conduct. They further recognize their responsibility to enforce sanctions against violations of these standards.

1. *As colleagues*, faculty members have obligations that derive from common membership in the community of scholars. Faculty members do not discriminate against or harass colleagues. They respect and defend the free inquiry of associates. In the exchange of criticism and ideas, faculty members show due respect for the opinions of others. They acknowledge their academic debts and strive to be objective in their professional judgment of colleagues. Faculty members accept their share of faculty responsibilities for the governance of their institution. When faculty members have concern about the professional behavior of a colleague, they apprise the individual of their concern and attempt to resolve the matter collegially.

2. *As members of an academic institution*, faculty members aspire to improve their effectiveness as teachers and scholars. Although faculty members observe the stated regulations of their institutions, provided the regulations do not contravene academic freedom, they maintain their right to criticize and seek revision. Faculty members give due regard to their paramount responsibilities within their institution in determining the amount and character of work done outside it. When considering the interruption or termination of their service, they recognize the effect of their decisions upon the program of the institution and give due notice of their intentions.

3. *As members of their community*, faculty members have the rights and obligations of all citizens. They measure the urgency of these obligations in the light of their responsibilities to their students, to their subject areas, to their profession, and to their institutions. When they speak or act as private persons, they avoid creating the impression that they speak or act for their college. As citizens engaged in a profession that depends upon freedom for its health and integrity, faculty members have



General Information

a particular obligation to promote conditions of free inquiry and to further public understanding of academic freedom.

4. *Respecting students as individuals* is an ethical imperative. All students, as individuals, deserve the respect of faculty members regardless of their cultural background, ethnicity, race, gender, religious beliefs, political ideologies, disabilities, sexual preference, age, or socioeconomic status. One of the challenges of educators is to reach their students at their current level of understanding. When relating to students as individuals, faculty members recognize the unique circumstances of each student's life. In particular, some students may possess learning styles which hinder them from benefitting from traditional methods of instruction. Faculty members have the responsibility to use all possible effective pedagogical tools to reach those students. Because students look to faculty as role models, not only must faculty exhibit an appreciation and respect for students from all backgrounds, but it is also imperative that they model behavior that is tolerant, appreciative, and respectful of others throughout the academic community.

CODE OF CONDUCT STATEMENT

Those acting on behalf of the College have a responsibility to conduct themselves in a manner that will maintain civility, strengthen the public's trust and confidence in the integrity of the institution, and take no actions incompatible with their obligations to the College.

Those representing or acting on behalf of the College should promote:

- Commitment to student success and student learning;
- Integrity by maintaining an ongoing dedication to honesty and responsibility;
- Trustworthiness by acting in a reliable and dependable manner;
- Fairness by treating others with impartiality;
- Respect by treating others with civility;
- Stewardship by exercising custodial responsibility for College property and resources;
- Compliance by following State and Federal laws and regulations and College policies related to their duties and responsibilities;
- Confidentiality by protecting the integrity and security of College information such as student records, employee files, and contract negotiation documents;
- Conflict resolution; and
- A climate of tolerance and trust conducive to the pursuit of College goals.

COLLEGE ADVISORY COMMITTEES

Interaction with community residents provides an essential channel of communication through which the College informs the communities of its programs and is informed about special educational needs. Vocational advisory committees are drawn from the professional and business communities to assist in the evaluation of vocational programs and other advisory committees assist in the development and review of various college programs.

This college-community exchange provides the College with sources of information that supplement the professional knowledge and information provided by the faculty, students, and staff.

Advisory committees include Administration of Justice, Business, Child Development, Culinary Arts Foster Parent, Independent Living, and Specially-Funded Projects Advisories, Computer Applications & Office Technologies, Computer Science, Culinary Arts, Family & Consumer Studies, Gerontology, Law/Paralegal & Multimedia.

By encouraging many avenues of communication among faculty, students, staff and community, Los Angeles Mission College strives to provide a personalized and meaningful educational environment for every one of its students. It is our continuing hope to serve the communities of the Northeast San Fernando Valley in a manner which meets their needs and encourages their participation.

Our Mission Is Your Success



COLLEGE FACILITIES & LOCATIONS

Los Angeles Mission College continues to make educational programs available to the communities of the North San Fernando Valley. The campus is located in the city of Sylmar. The facilities include classrooms, library/learning center, child development center, computer commons, student store, faculty offices, administrative offices and parking structure. Additionally, various off-campus facilities are utilized in the offering of extended-day and outreach programs.

PUBLICATIONS

The College publishes the annual Catalog, two semester schedules of classes (Spring and Fall), summer session and winter intersession schedules, if offered, and all brochures and recruitment materials. Submissions for inclusion in any publication or requests for a new publication must be made through the Office of Academic Affairs. Publications are available at the Admissions and Records Office and at a number of convenient locations throughout the campus.



Admission & Registration



Admission Eligibility

Persons who possess a high school diploma or its equivalent meet the basic eligibility requirement for admission to any public California two-year community college.

Persons who do not possess a high school diploma or its equivalent but meet additional criteria are also eligible for admission if, in the judgment of the College Admissions Officer, they are capable of profiting from the instruction offered. Additional eligibility criteria include the following:

- Persons who are eighteen (18) years of age or older
- Persons who are apprentices, as defined by Section 3077 of the California Labor Code
- Persons in grades K-12, under special circumstances

The Los Angeles Community College District maintains a student record system that uses assigned identification numbers to identify an individual's records. This number shall be used at all campuses in this District. Changes in a student identification number may be made only in the Admissions Office.

Information regarding other eligibility criteria and/or admission procedures is available in the Office of Admissions and Records. Students may receive Admissions and Records information by calling the department directly at 818.833.3322 during regular office hours. Students may also receive more detailed information online at our webpage: www.lamission.edu/admissions

Student Success & Support Program – Matriculation Process

Senate Bill 1456 revised and renamed the Matriculation Act of 1986 as the Seymour-Campbell Student Success Act of 2012. Signed by Governor Brown on September 27, 2012, the program began on January 1, 2013 and will be implemented through stages over a five-year period.

The Student Success and Support Program (formerly Matriculation) supports the transition of new students into the college by providing services that promote academic achievement and successful completion of degrees, transfer preparation, career technical education certificates, or career advancement.

Effective Fall 2014, based on student responses to the Los Angeles Mission College application for admission, students will be identified as matriculating or non-matriculating. Students identified as matriculating are referred to core matriculation services: assessment placement, orientation, and counseling. Students must complete the assessment placement, orientation, and counseling (abbreviated student educational plan) prior to their priority registration date and time. The abbreviated student educational plan is provided during the in-person orientations. After registration and sometime during the semester, a comprehensive student educational plan must be completed within a reasonable time period by making an appointment to meet with a counselor. Non-matriculating students are exempt from participating in the core matriculation services, but are advised to access these services if they plan to pursue a degree or certificate.

Please be advised that per LACCD policy, only online applications will be accepted by Admissions. However, in rare and unusual circumstances, paper applications may be accepted with prior administrative approval.

STUDENT RIGHT AND RESPONSIBILITIES: (TITLE 5 SECTION 55530)

- Identify an educational and career goal.
- Diligently engage in course activities and complete assigned coursework.
- Complete courses and maintain progress toward an education goal and completing a course of study.
- Matriculating Student:
 - a. Must identify a course of study.
 - b. Participate in the assessment placement process.
 - c. Complete an orientation activity provided by the college.

- d. Participate in counseling to develop at minimum an abbreviated student education plan.
- e. Failure to complete a, b, c, and d (above) may result in a hold on a student's registration or loss of registration priority until the services have been completed.
- f. A comprehensive educational plan must be completed by the 3rd semester or after completion of 15 semester units of degree applicable coursework (effective Fall 2015).

STATEMENT OF PHILOSOPHY

Los Angeles Mission College is committed to serving adults of all ages who can profit from instruction and provides open access to programs in transfer, occupational, general, transitional and continuing education, as well as community services.

In carrying out these functions and responsibilities, the District colleges have an obligation to assist students in attaining their educational goals by providing information and guidance concerning the choices that are available to them. Students, in turn, have a responsibility to pursue their goals with respect for college standards and a sense of accountability in the use of public funds.

The Matriculation Process: A Step-By-Step Guide

STEP 1 – COMPLETE & SUBMIT AN ONLINE APPLICATION FOR ADMISSION

- GO TO: www.lamission.edu
Click on "Apply Online"
- You will be sent directly to the CCCApply.Org website, where you will follow the steps listed on the website.

STEP 2 – ASSESSMENT

Campus Center Lower Level, Room 1529
ALL students who have submitted an application

and have been issued a STUDENT IDENTIFICATION NUMBER are required to take the assessment tests in English or English as a Second Language (ESL) and Math, unless exempt (please refer to exemptions below). The assessment process helps to place students in classes where they are most likely to succeed. Assessments are available on a walk-in basis, Monday through Thursday. See website for current office hours: www.lamission.edu/assessment. Students must have their LACCD ID number and present a valid form of picture ID prior to taking the assessment tests.

PLEASE NOTE: The Math assessment process requires students to self select the appropriate test level (Algebra Readiness, Elementary Algebra, Intermediate Algebra or Pre-Calculus). For more information on choosing the appropriate Math assessment test, please visit www.lamission.edu/math/MDTP%20sample%20test%20and%20guide.aspx

Any student with a verified disability may arrange for alternative administration of the Assessment Placement Process (English, Reading, and Mathematics) by contacting the Disabled Student Program and Services (Instructional Building Room 1018) at 818.364.7732

For More Information

- Visit www.lamission.edu/assessment/default.aspx
- Stop by the Assessment Office in the Campus Center Lower Level Room 1529
- Call 818.364.7613

Assessment Exemption

New students can request to be exempted from the assessment component if they meet any one of the following conditions:

- Participated in assessment placement services at another California Community College outside of the Los Angeles Community College District (LACCD) within the past two years.
- Participated in the Early Assessment Program (EAP) and received college-level placement in

English and/or math. (Please note that conditional acceptance is not accepted.)

- Completed both an English and/or ESL & Math course at another college/university.

LACCD Matriculation Assessment Exemption Request Process

Students will need to submit an "LACCD Matriculation Assessment Exemption Request" (download at www.lamission.edu/sssp/exemptions) with appropriate documentation to the Admissions Office located in the Student Services Wing of the Instructional Building. This form will clear any English, ESL and/or Math course prerequisites met. This process usually takes up to 10 working days.

STEP 3 – GROUP OR ONLINE ORIENTATION

Once the assessment tests have been completed and results received, students may sign-up in the Student Success Center or in the Counseling Office to attend a group or online orientation. It is highly recommended for all new students to attend an orientation session unless exempt (please refer to exemptions below). After group orientations, a counselor will review the College Catalog and Schedule of Classes to assist in planning the first semester abbreviated student educational plan. Students who complete the online orientation will need to meet with a counselor in the Counseling Office to develop the abbreviated student educational plan (SEP). Group or Online orientation presents important information about the college, educational programs, requirements, resources and services that will help students register for classes and succeed in meeting their goals.

For More Information

- Visit www.lamission.edu/sssp
- Stop by the Student Success Center (lower level of the Campus Center) or the Counseling Office (Student Services Wing of the Instructional Building)
- Call 818.364.7700

Admissions & Registration

STEP 4 – COUNSELING

All new and returning students should meet with a counselor before registering for courses unless exempt (please refer to exemptions below). Meeting with a counselor regularly, provides an opportunity to review educational goals, course requirements, research majors, and plan courses. New students will need to declare a program of study and complete a comprehensive student educational plan before the completion of 15 degree applicable units. It is **HIGHLY** recommended that students meet with a counselor each semester to receive updates on changes and review progress towards their educational goal.

Please contact the Counseling Office at 818.365.7655 for appointment and drop-in counseling availability.

For More information

- Visit www.lamission.edu/counseling
- Stop by the Counseling Office in the Instructional Building, Administration Wing
- Call 818.364.7655 or 818.364.7656

STEP 5 – APPLY FOR FINANCIAL AID

All students are encouraged to apply for financial aid. Eligible students should complete the Free Application for Federal Student Aid (FAFSA) online at www.fafsa.gov. The FAFSA is used to determine eligibility for federal and state financial aid, including grants, work-study, and loans. California residents can also apply for the Board of Governor's (BOG) Fee Waiver through either the FAFSA or a separate paper application, available at the Financial Aid Office and on our website at www.lamission.edu/financialaid, under "Apply for a Fee Waiver." Eligible AB540 students can apply for state financial aid (BOG fee waiver and Cal Grants) through the California Dream Act application, available online at www.caldreamact.org

STEP 6 – REGISTER FOR YOUR COURSES

Beginning fall 2014, the enrollment priorities will change. The following registration groups will register in this order:

Group 1: New and fully matriculated students as follows:

- Members of the armed forces of veterans in good standing with fewer than 100 degree-applicable units
- DSPS in good standing with fewer than 100 degree applicable units
- EOPS student in good standing with fewer than 100 degree-applicable units, and
- Foster youth, regardless of academic standing and units taken. CalWorks.

Group 2: Continuing students in good standing with fewer than 100 degree-applicable units, middle college student in good standing with fewer than 100 degree-applicable units, new, fully matriculated student, returning except.

Group 3: Students who have lost their enrollment priority

Group 4: Continuing K- 12 students, new and returning K-12 students and K-12 students.

Register for Courses Online

Check online at www.lamission.edu to verify that your class is open. Have your class section numbers ready.

1. Have your STUDENT IDENTIFICATION NUMBER ready before you log on
2. Have your four digit pin number ready, which is your birth day and month without the year
3. Go to www.lamission.edu and click on "Register for Classes" on the top right
4. Log in with your Student Identification Number and four digit pin
6. Click on "Registration"
7. Select "Los Angeles Mission College" as the college choice
8. Select the Semester and Year

9. Select "Add" and enter the course Section Number
10. Click "Submit"

EXEMPTIONS (TITLE 5 SECTION 55532)

Subject to change based on LACCD district board rules and policies.

Effective 2015, in compliance with SB 1456 - Student Success Act of 2012, all new students are expected to participate in the core matriculation services of Assessment, Orientation, and Counseling (Abbreviated SEP). However, some students may be exempted from these services if one or more of the following apply, if the student:

- Has completed an associate degree or higher. (As determined & certified at the time of Admission Application).
- Has enrolled at the college for a reason other than career development or advancement, transfer, attainment or a degree or certificate, or completion of a basic skills or English as a Second-Language course sequence. (Student needs to submit LACCD Matriculation Assessment Exemption Form)
- Has completed these services at another community college within a time period as identified by the district; (Student needs to submit LACCD Matriculation Assessment Exemption Form)
- Has enrolled at the college solely to take a course that is legally mandated for employment as defined in section 55000 or necessary in response to a significant change in the industry or licensure standards. (Student needs to submit LACCD Matriculation Assessment Exemption Form)
- Has enrolled at the college as a special admit student pursuant to Education Code section 76001. (As determined & certified at the time of both Admission Application & Concurrent K-12 Form)

If you meet one of these conditions you will be exempted from the core matriculation services and shall be notified at the time of submitting the admission application.

STUDENT AGREEMENT

Matriculation is a program that connects Los Angeles Mission College with the students who enroll for credit courses into an agreement for the purpose of realizing the student's educational goals through the college's programs, policies, and requirements.

Under this agreement, students are required to

1. Express at least a broad educational intent upon admission,
2. Declare a specific educational goal no later than the term after which the student completes fifteen (15) semester units of degree-applicable credit courses,
3. Diligently attend class and complete assigned coursework,
4. Complete courses and maintain progress toward an educational goal, and
5. Cooperate in the development of a Student Educational Plan with the assistance of counseling services.

If a student fails to fulfill the responsibilities listed above, the college may suspend or terminate matriculation services, however, the college will not terminate any service to which a student is otherwise entitled.

TERMINOLOGY

Prerequisite

A class or skill you must have prior to enrolling in the target class. The faculty of that discipline requires the prerequisite because they feel it is necessary for you to succeed in the target course

Corequisite

A class that must be taken simultaneously with the target course. A corequisite may be completed with passing grade ("C" or better) prior to enrollment in the target course

Advisory

A class or skill you are advised to have, but not required to have, prior to enrolling in the target course

Target Course

Any course which the faculty has determined that requires completion of a prerequisite, corequisite, or advisory course

Placement Level

The outcome from the assessment process which is used for placing students into the appropriate level of English, Mathematics, and English as a Second Language courses

PREREQUISITE CHALLENGE PROCEDURE

All students need to demonstrate meeting the prerequisite or corequisite requirement in order to enroll into the target course.

- If the student satisfies the requirements by completing a class with a grade of "C" or better at LAMC or through the assessment process, he/she will be cleared for registering into the target course.
- If the student has satisfied the prerequisite or corequisite and/or placement at another college or through another method, he/she must submit the appropriate documentation (i.e., a transcript and/or placement results) to the counseling Office located in the Instructional and Student Services Building.

Once a counselor reviews the documents and finds that the prerequisite or corequisite has been satisfied, the counselor will issue a course placement authorization form. This form, once signed by the counselor, needs to be turned into the Admissions Office along with the necessary add slip by the student for processing. Students without transcripts or other proof of meeting the specified prerequisite or corequisite but who believe that they have other clear and reliable evidence that they are adequately prepared to take the target course may go through the prerequisite or corequisite challenge process.

RIGHT TO CHALLENGE PREREQUISITES

Students have the right to file a challenge for any prerequisite or corequisites. Challenges can be based upon the following:

- The student has the knowledge or ability to succeed in the target course despite not meeting the prerequisite or corequisite. (Criteria for challenging based on knowledge or ability to succeed will be determined by each Academic Department.)
- The prerequisite or corequisite is not valid because it has not been established in accordance with the District's policy.
- The prerequisite or corequisite is being applied in an unlawfully discriminatory manner.
- The prerequisite or corequisite has not been made reasonably available, causing the student undue delay in completing his/her educational goal.

PREREQUISITE CHALLENGE PROCESS

1. Pick up the challenge form at the Counseling Office. It is required that students seeking to go through the challenge process meet with a counselor to discuss the process in further detail.
2. All challenge forms must be submitted at least five (5) working days prior to the first day of instruction as stated in the Schedule of Classes (PLEASE NOTE: the challenge process takes five working days to complete). Challenges filed after this deadline will be considered for the following semester. If the challenge is approved or the college fails to resolve the challenge within five (5) working days, the student shall be allowed to enroll in the course.
3. Once a petition packet is complete (including standard and discipline specific documents), the student will deliver it to the department responsible for the prerequisite or corequisite course. Once a complete packet is received, the department will have five (5) working days within which to make its decision, whereupon the department chair or department designee will sign and date the petition. Incomplete petition packets will not be accepted. If the Chair and/or Vice Chair is the instructor of the course that the student wishes to enter, then the Chair and/or Vice Chair will identify another faculty

Admissions & Registration

member in the discipline to review and approve the challenge form.

4. Upon review of the challenge, within three (3) working days of reaching its decision, the responsible department will attempt to notify the student using contact information provided on the petition form. All students requesting further information will be directed to contact the counselor of record. A copy of the form will be filed in the department office and the original will be returned to the counseling department.
- If the challenge is approved, the student must obtain a course placement authorization from the counseling department and take it to Admissions along with the necessary add form for processing.

APPEALING A CHALLENGE DETERMINATION

Challenge Determination Appeal Process

A student may appeal the validity of this challenge by filing the appeal with the Vice President of Academic Affairs. To appeal the student must submit a copy of the challenge form, supporting documentation and, if applicable, a brief statement explaining the reason for the appeal (beyond the written explanation already on the challenge form), via a general petition form that may be obtained in the Counseling Office.

PLEASE NOTE: Appeals will ONLY be processed for challenges that were reviewed and signed by one faculty member. If the challenge was reviewed and signed by a minimum of two faculty members (the department chair or designee and an additional faculty in the discipline) then the appeal will NOT be considered.

Challenge Determination Appeal Process

1. Student receives the challenge results from the Department or Counseling Office.
2. The student must complete a general petition form which may be obtained from the Counseling Office.
3. The completed petition and all accompanying documentation that supports the appeal (the general petition, a copy of the original challenge form and any other supporting documentation) is submitted to the Vice President in the Office of Academic Affairs.

4. The Vice President of Academic Affairs will convene a committee to review the appeal. The Committee will consist of the Vice President of Academic Affairs or designee, a counselor from General Counseling and the Department Chair, Vice Chair or a designee of the Department denying the initial challenge.
5. The copy of the general petition appeal will be forwarded to the Counseling office to be filed with the original Challenge form. If the appeal is granted, the counselor will prepare a course authorization to be picked up from the General Counseling Office.
6. The Student will be contacted by the Office of Academic Affairs via email regarding the outcome of the appeal. If the appeal is granted the student will be directed to pick up a course authorization in the General Counseling Office.
7. All appeal decisions that occur after the "Add Deadline" will be for course enrollment in the following semester.

Residency Requirements

CALIFORNIA RESIDENCE REQUIREMENTS

To attend any of the Los Angeles Community Colleges as a resident of California, a student is required to have been a California resident for more than one year immediately preceding the "Residence Determination Date." The Residence Determination Date is that day immediately preceding the opening day of instruction of the semester or summer session. Residence is defined as a union of act and intent.

NONRESIDENT

A nonresident student is one who has not had residence in the State of California for more than one year immediately preceding the Residence Determination Date. Residence is defined as a union of act and intent. Physical presence alone is not sufficient to establish California residency, nor is intent when not coupled with continuous physical presence in the state. Certain non-United States citizens are permitted to

establish residency, and certain others are not. Check with the Admissions Office regarding your particular status. A student classified as a nonresident will be required to pay nonresident tuition fees as established by the District Board of Trustees. For the year 2016-2017 the non-resident tuition fee will be \$193 and the capital outlay fee will be \$22.

RESIDENCE RECLASSIFICATION

Students who have been classified as nonresidents must reapply to be reclassified as residents at any time they feel their status has changed. An updated application should be submitted to the Admissions Office. The new application must be submitted prior to the semester in which reclassification as a resident is to be effective. A Supplemental Residency Questionnaire may also be requested by the Admissions Office.

RESIDENCE CLASSIFICATION APPEAL

A student may appeal the residence classification determined by the College. The appeal must be made within 30 calendar days of receipt of notification of the residence classification from the Admissions Office. The appeal must be submitted in writing to the college Admissions Office, which will forward it to the District Residency Appeal Officer.

CALIFORNIA NONRESIDENT TUITION EXEMPTION FOR ELIGIBLE CALIFORNIA HIGH SCHOOL GRADUATES

(The state law passed by the California Legislature in 2001, known as "AB 540")

General Information

Any student, other than a nonimmigrant alien, who meets all of the following requirements, shall be exempt from paying nonresident tuition at California Community Colleges, California State University, and University of California (all public colleges and universities in California).

Requirements

1. The student must have attended a high school (public or private) in California for three or more years.

2. The student must have graduated from a California high school or attained the equivalent prior to the start of the term (for example, passing the GED or California High School Proficiency exam).
3. An alien student who is without lawful immigration status must file an affidavit with the college or university stating that he or she has filed an application to legalize his or her immigration status or will file an application as soon as he or she is eligible to do so.
 - Students who are nonimmigrants (for example, those who hold F [student] visas, B [visitor] visas, etc.) are not eligible for this exemption.
 - Students must file an exemption request with the college including a signed affidavit that indicates the student has met all applicable conditions described above. Student information obtained in this process is strictly confidential unless disclosure is required under law.
 - Students eligible for this exemption who are transferring to another California public college or university must submit a new request (and documentation if required) to each college under consideration.
 - Nonresident students meeting the criteria will be exempted from the payment of nonresident tuition, but they will not be classified as California residents. They continue to be “nonresidents.”
 - AB 540 does not provide student financial aid eligibility for undocumented alien students. These students remain ineligible for state and federal financial aid.

Procedures for Requesting the AB540 Exemption from Nonresident Tuition

California Community Colleges - The AB540 Exemption Form, available in the Admissions and Records Office, should be submitted to the Admissions Office at the community college where

you are enrolled or intend to enroll. You may be required to submit additional documentation. Call the college Admissions Office if you have questions.

University of California - The AB540 Exemption Form, available in the Admissions and Records Office, should be submitted to the Office of the Registrar at the UC campus where you are enrolled or intend to enroll. Your campus has established deadlines for submission of exemption requests; however, requests are not to be submitted until students have been admitted to a UC campus. Some students, such as transfer, graduate, and professional students, also must submit their official high school transcripts; check with each campus regarding specific instructions. Once students are determined to be eligible for the exemption, they will continue to receive the exemption as long as they fulfill the eligibility requirements or until the University no longer offers this exemption. The exemption covers the Nonresident Tuition Fee and the Educational Fee differential charged to nonresident students. Applying for the exemption does not alter students’ responsibility to pay by the campus deadline any nonresident tuition and associated fees that may be due before their eligibility is determined.

For campus-specific instructions regarding documentation and deadline dates, contact the campus Office of the Registrar.

California State University - The AB540 Exemption Form, available in the Admissions and Records Office, should be submitted to the Office of Admissions and Records at CSU campus where you are enrolled or intend to enroll. You will be required to submit final high school transcripts and appropriate records of high school graduation or the equivalent, if you have not done so already. For instructions on submission, deadline information and additional requirements call the Office of Admissions and Records at the CSU campus.

International Students Admissions

Prospective nonimmigrant students and transfer (nonimmigrant students with valid “F” visa status), require the following to be considered for enrollment:

1. Be at least 18 years of age.
2. Submit completed International Student Application Package:
www.lamission.edu/international
3. Provide proof of adequate monetary funds to cover their entire costs of tuition and fees, housing and other living expenses.
4. Students are required to take the College Placement Assessment for English in place of the TOEFL exam.
5. Applications are accepted on a year-round basis.
6. Plan to arrive at the college up to 30 days but not less than one week prior to the date of enrollment.
7. All F-1 Visa Students are required to contact the International Student Office upon arrival. International students must enroll in a minimum of 12 units per semester, are classified as nonresident students, and must pay the regular tuition fees in addition to international student tuition fees, mandatory I-Med health insurance fee, SEVIS fee and the campus health fee for the duration of F1 status. F2 Visa students may enroll in 6 units or less of avocational courses. Grants-in-aid are not available to international students.

Effective April 12, 2002, the Department of the United States Citizenship and Immigration Services has issued an Interim Rule which requires those with B visas to change their visa status to an F-1 Student Visa prior to pursuing a course of study at a college.

International Students may not apply online.

Admissions & Registration

ESTIMATED INTERNATIONAL STUDENTS EXPENSES FOR ONE ACADEMIC YEAR		
There is a one-time fee of \$35 for the processing of the F1/I-20 Visa		
Item of Expense	Per Semester	Per Year
Nonresident Tuition (\$222 x 12 units)	\$2,664	\$5,328
Enrollment Fee (\$46 x 12 Units)	552	1104
Health Service Fee	11	22
Representation Fee	1	2
District SEVIS Fee	25	50
International Student Health PPO Plus	618	1,236
Total Tuition and Fees	\$3,871	\$7,742
Personal Living Expenses/ Room and Meals (May be less if living with relatives or sharing living quarters)	5,000	10,000
Student is responsible for costs of all Books and Supplies. Transportation Cost: Varies depending upon choice of transportation mode.		
Total Verified Expense Amount*		\$17,742

*Questions regarding Estimated International Students Expenses may be sent to estradgm@lamission.edu or call the International Student Office at 818.364.7741.

Fees & Costs

LAMC will be writing the new student identification (ID) number (not the social security number) on the front of all checks received for payment of fees, services, etc. If you do not wish to have this new student ID number written on your check, you may change your mode of payment (cash, credit card or money order).

ENROLLMENT FEE

Section 72252 of the Education Code requires community colleges to charge an enrollment fee of each student enrolling in college. The fee prescribed by this section shall be forty-six dollars (\$46) per unit per semester.*

Financial aid may be available to students who meet the qualification requirements. Students with questions concerning financial aid eligibility should contact the College Financial Aid Office. Applications should be submitted as soon as possible.

*Fees are subject to change without prior notification.

Enrollment Fee Assistance

The College offers enrollment fee assistance, called the Board of Governors (BOG) Fee Waiver, to students who are unable to pay the enrollment fee. You are eligible to apply for a waiver if you are a California resident and you are enrolled in at least one unit. You qualify if any one of the following statements apply to you.

- A. At the time of enrollment you are a recipient of benefits under the TANF/CalWORKs Program, SSI (Supplemental Security Income), or General Assistance (also known as General Relief).
- B. You meet the following income standards (Income Standards for 2012-2013)

Number in Household (Including Yourself)	Total 2013 Family Income (Adjusted Gross Income and/or Untaxed Income)
1	\$16,245
2	\$21,855
3	\$27,465
4	\$33,075
Each additional family member income	Add \$5,610

NOTE: The income standards for the Fee Waiver Program may change every year. Check with the Financial Aid Office for current income standard information.

C. You are qualified for need-based financial aid. If you qualify under this criteria, you will need to complete the Free Application for Federal Student Aid (FAFSA). If you qualify for financial aid after you pay your enrollment fees, you should complete a "Request for Refund" form available in the College Business Office.

D. Special Classifications

1. You have certification from the California Department of Veterans Affairs or the National Guard Adjutant General that you are eligible for a dependent's fee waiver. You must submit certification.
2. You have documentation that you are eligible as a recipient of the Congressional Medal of Honor or as a child of a recipient, or a dependent of a victim of the September 11, 2001, terrorist attack. You must submit documentation from the Department of Veterans Affairs or the CA Victim Compensation and Government Claims Board.
3. You have documentation that you are eligible as a dependent of a deceased law enforcement/ fire suppression personnel killed in the line of duty. You must submit documentation from the public agency employer of record and income information.
4. If you are in a Registered Domestic Partnership (RDP), you will be treated as an independent married student to determine eligibility for the fee waiver and will need to provide income and household information for your domestic partner. If you are a dependent student and your parent is in a Registered Domestic Partnership, you will be treated the same as a student with married parents, and income and household information will be required for the parent's domestic partner.

ENROLLMENT FEE REFUND POLICY

For full-term courses - The student will receive a full refund up to the end of the second week of classes. There will be no refunds after that, unless a class is canceled or rescheduled by the administration or college. Refunds are not automatic; students must request a refund at the Business Office.

For short-term courses - The student will receive a full refund up to the end of a period of time equal to 10 percent of total class time. There will be no refunds after that, unless the class is canceled or rescheduled by the administration or College.

Any student who is a member of an active or reserve United States military service and who has withdrawn from courses due to military orders may file a petition with the district requesting refund of the enrollment fee.

The district shall refund the entire enrollment fee unless academic credit has been awarded.

HEALTH SERVICES FEES

The Los Angeles Community College Board of Trustees at its April 29, 1992, meeting modified Board Rule 8502, thus making the \$11 Health Services fee a mandatory fee for all students enrolled in credit classes. Health Fees are no longer waived for students who are recipients of the Fee Waiver.

The Los Angeles Community College District policy exempts the following students from paying the student health fee: (a) students who depend exclusively on prayer for healing in accordance with the teaching of a bona fide religious sect, (b) students who are attending classes under an approved apprenticeship training program, (c) non-credit education students, (d) students enrolled in district colleges exclusively at sites where student health services are not provided, (e) students who are enrolled in district colleges exclusively through

Instructional Television or distance education classes, and (f) students who are enrolled in district colleges exclusively through contract education. Students exempted under the provisions of (a), (c) and (d) above are eligible to receive the services of the college health program; all other exempted students are not eligible to receive the services of the college health program. Exemption Request must be submitted to the Admissions and Records office.

Your registration fee receipt or your current student ID must be presented to receive services.

NONRESIDENT TUITION FEE

The tuition fee for nonresident (international) students is \$222 per semester unit. The tuition fee for nonresident (out-of-state) students is \$222 per semester unit. Fees MUST be paid at the time of registration and are subject to change each academic year.

NOTE: Nonresident students are also required to pay the community college enrollment fee of \$46 per unit and other fees as mandated.

NONRESIDENT IMED FEE

Effective Fall 2007, International students attending LACCD under an I-20 issued by a college in the district are required to pay a Medical Insurance Fee per semester. The rate for 2016-2017 will be \$103 per student/per month.

Please see following LACCD International Insurance Rates and Dates for 2016-2017:

DATES AND RATES OF COVERAGE

Fall - 8/15/16 to 1/31/17 Student Premium

Rates: \$636.00

Winter - 12/15/16 to 1/31/17 Student Premium

Rates: \$212.00

Spring/Summer - 2/01/17 to 8/14/17 Student

Premium Rates: \$618.00

Summer - 5/15/17 to 8/14/17 Student Premium

Rates: \$318.00

NONRESIDENT TUITION REFUND CRITERIA & SCHEDULE

A nonresident F-1 Visa student who formally drops or otherwise separates from part or all of his or her enrollment may request a refund of previously paid nonresident tuition in accordance with the schedule below. Such requests must be made in writing and are subject to the International student advisor's approval. The date used for nonresident refund purposes is the date on which the request is filed and time stamped, regardless of when separation may have occurred. All nonresident refunds will be made by mail.

CHART A (Nonresident Refunds)		
CLASS TYPE	Date Request Time Stamped	Refund
SHORT TERM (Less than regular length)	Thru 10% of class length	Full Tuition
	After 10% of class length	No Refund
REGULAR (Fall, Spring, Summer)	Thru second week	Full Tuition
	After second week	No Refund

ASSOCIATED STUDENTS ORGANIZATION FEE

Membership in the Associated Students Organization of Los Angeles Mission College is \$7 per semester. ASO fees support cultural, social, and co-curricular activities that are sponsored by the ASO. Participation in ASO entitles members to eligibility for ASO scholarships, computer and Internet access, free Scantrons and blue books (limited number), legal advice, tutoring, and discounts on goods and services from selected locations within the community. Membership in the ASO is not mandatory.

Admissions & Registration

ASSOCIATED STUDENTS ORGANIZATION FEE REFUND POLICY

A full refund of the ASO fee will be made up to the end of the second week of the semester. Thereafter, no refund is authorized.

DUPLICATE RECEIPTS

A \$1 fee will be charged for all duplicate receipts.

INSTRUCTIONAL MATERIALS

Students may be required to provide instructional and other materials required for a credit or non-credit course. Such materials shall be of continuing value to a student outside of the classroom setting and shall not be solely or exclusively available from the District.

PARKING FEE

Parking in all L.A. Mission College lots is by parking permit only. Student parking permits will be sold in the Business Office for \$20 for the full-length semester and \$10 for the summer and winter sessions. Vehicles that do not have a valid parking permit properly displayed on the vehicle will be cited. Please read the section on Student Parking Regulations.

SERVICE CHARGE FOR RETURNED CHECKS

A \$10 service charge must be paid for all returned checks (e.g., insufficient funds, stop payment, account closed, etc.)

STUDENT REPRESENTATION FEE

In accordance with the Education Code Section #76060.5, Los Angeles Mission College created the Student Representation Fee through the election process. This fee became effective in the Fall 1996 semester for the amount of \$1. The money collected is to be used to provide for the support of governmental affairs representatives who may be stating their positions and viewpoints before city, county, and district governments, and before offices and agencies of the state government.

Although this is a mandatory fee, a student may refuse to pay for religious, political, financial, or moral reasons. The waiver must be submitted to the college Business Office.

TRANSCRIPT & VERIFICATION FEES

TRANSCRIPTS (first two regular copies free)	FEE*
Transcripts (Will be mailed 5 to 7 business days)	\$3 each copy
Rush Transcripts (On the spot or mailed next day)	\$10 each copy
Verifications (Will be mailed 5 to 7 business days)	\$3 each copy
Rush Verifications (On the spot or mailed next day)	\$10 each copy

**Fees are subject to change by the Los Angeles Community College district Board of Trustees without further notification.*

ADMISSIONS TRANSCRIPT POLICY

Transcripts and verifications will take five to seven working days to process and will be sent by regular mail. Rush transcript and rush verification requests received by mail will be processed within 24 hours with a next day postmark and will be sent through regular mail. Rush transcripts and verifications for pickup will be processed while the student waits. A picture identification is required for pickup. Written authorization is required to request transcripts or verifications by a person other than the student.

In addition, payment needs to be done by cash, Cashier's check or money order due to Business Office procedure changes.

College & High School

Students may get a start on their college education by taking classes at Los Angeles Mission College while they are still in high school. Students may attend college classes on a limited basis with a permit from their high school counselor.

GETTING STARTED

Students may apply for admission while still in high school. Each semester that they wish to co-enroll, they will need to submit a high school counselor's permit. If students need assistance, they should see their high school counselor or contact the Los Angeles Mission College Recruitment Office at 818.364.7779.

CONCURRENT ENROLLMENT

Rules to know when attending college and high school classes at the same time:

- Classes available on campus or via the Internet or courses given on high school campuses.
- For English, Math, or a Science class requiring Math you must take a placement test prior to enrolling into the course. Take the exam as soon as possible after you apply for admissions. You may set an appointment or attain the Assessment Office's hours by calling 818.364.7613.

COST PER UNIT

The first 11 units for concurrently enrolled high school students are "free," as long as there are not any restrictions to your admissions process.

JUMP START ON COLLEGE

Community College units assist students to attain high school credits and graduate, they assist students to "get ahead" in their college requirements, and courses that are marked transferable will also transfer to the UC, CSU or Private University of their choice.

AB 540 is a State bill which allows students to enroll into college as a California Resident, and co-enrollment will be implemented for those who qualify. Regulations do apply, for more information please feel free to call our admissions office at 818.833.3322.

AUDITING CLASSES

Students may be permitted to audit a class under the following conditions:

1. Payment of a fee of \$15 per unit. Fees may not be refunded.
2. Students auditing a course shall not be permitted to change their enrollment in that course to receive credit for the course.
3. Priority in class enrollment shall be given to students desiring to take the course for credit.
4. Permission to enroll in a class on an audit basis is at the instructor's discretion.
5. Participation in class activities by student auditors will be solely at the discretion of the instructor, who may provide a written statement of the extent of participation allowed beyond observation.
6. Students may not drop classes taken on an audit basis.
7. Audited classes will not appear on the student transcript.

NOTE: See page 28 for Financial Aid policy regarding audited classes.

CANCELLATION OF CLASSES

The college reserves the right to cancel or change classes, instructors, or locations.

CHANGE OF PROGRAM

Program changes may be made starting the first full day of classes of the semester.

Add a Class

Students will be added into open classes until the add permit deadline. Students must obtain add permits from instructors once classes begin. If the instructor signs the add permit, the students must come to Admissions to process the add permit. The add permit deadline for semester length classes will be enforced by college administration.

Closed Classes/No Standby List

A student may request to be added by an instructor into a closed class. The add permit must be signed by the instructor and submitted to Admissions by the add permit deadline. Add permits for closed classes must be obtained from the instructor of record or the Department Chair. The college no longer uses standby lists. Students are advised to enroll in classes before the semester begins.

Drop a Class

Students may drop a class without the instructor's signature up to the twelfth week of a regular semester (16-week semester). Instructor approval is not needed to drop a class. Students are advised to drop a class by Internet. The student will receive a confirmation number if the process is successful.

DAY & EXTENDED DAY CLASSES (HOURS)

Los Angeles Mission College offers classes during the day and evening for the convenience of students. Day classes meet 7:00am to 3:25pm Monday through Friday. Extended day (evening) classes are those scheduled to start at 3:30pm or later.

FULL-TIME & PART-TIME STUDENTS

For purposes of establishing eligibility for financial aid, veterans' benefits, athletics and other activities, students taking 12 units or more are considered full-time students; those taking fewer than 12 units are considered part-time students. Veterans enrolled in 6 units or more during the summer or winter semesters will be considered full-time for veteran benefits.

OPEN ENROLLMENT

Unless specifically exempted by law, every course for which state aid is claimed is fully open to any person who has been admitted to the College and who meets the appropriate academic prerequisites.

SUGGESTED STUDY LOAD

In consultation with teachers and counselors, each student should determine what is an appropriate program. Most of the educational programs at Los Angeles Mission College are designed so that the full-time student, taking 12 to 15 units a semester, can complete those programs in 4 or 5 semesters. However, the student who works or who has unusual off-campus responsibilities may find that enrollment in 12 to 15 units of collegiate courses is excessive. The student must be sure to schedule adequate time for rest, for study, and for consultation with instructors. A student who is not working and who has no other restrictions on his or her study efforts should enroll in a minimum of 12 units. For those students who wish to accelerate their education, a maximum of 18 units is allowed. (Minimum and maximum units are exclusive of the kinesiology activity requirement.)

In unusual circumstances, it may be warranted for a student to carry more than the normal load of classes. Authorization to carry such a load may be granted by the counselor advising the student depending upon the excellence of the previous semester's scholarship and attendance.

Student Information



Student Services

COUNSELING OFFICE

Academic – Career – Personal

818.364.7655 or 818.364.7656

All students are strongly urged to make an appointment with a counselor for help in choosing a course of study in order to complete a comprehensive student educational plan prior to the completion of 15 degree applicable units. Counseling assistance is also available for college transfer requirements, career planning, and personal concerns. To schedule a day or evening appointment, contact the Counseling Office.

Career Planning Center

Career workshops and individual appointments provide students an opportunity to evaluate personal abilities and interests, to explore occupational areas, and to decide on a career direction. The Eureka Computer Information System is available for use by appointment.

Student Educational Plan

Prior to enrollment and during an in-person orientation, all new students are advised to complete a one semester abbreviated student educational plan. Students will also need to select a course of study and complete a comprehensive student educational plan prior to the completion of 15 degree applicable units. The Student Educational Plan allows students to chart out a path to help them meet their educational goals. Students are advised to make an appointment to visit with a counselor each semester to ensure that their course selections are on track with their Student Educational Plan.

INTERNATIONAL STUDENT SERVICES (ISS)

818.364.7741

www.lamission.edu/international

Los Angeles Mission College welcomes F1 Visa students from other countries who choose to experience an American Education. Support services include assistance with obtaining an F1 Visa, F2 Dependent Visas, SEVIS Transfer requests and concurrent enrollment. The International Student Advisor is available to assist F1 Visa students throughout their college experience.

All international students must meet with the International Student counselor to create a Student Education Plan (SEP) in accordance with United States Citizenship and Immigration Services (USCIS) regulations. Additional information, applications, and necessary forms may be found at the LAMC ISS webpage.

NEW STUDENT ORIENTATION & ASSESSMENT PROGRAM

818.364.7613

After new students submit their college application to the Admissions Office, they should complete the assessment and orientation process before enrolling in their first semester. Please call the Assessment Center for assessment times and dates. Online Orientation appointments are given at the assessment sessions. The Online Orientation may also be done from home or any internet capable computer by going to following website: lamission.edu/orientation. The online orientation provides important information about college programs, requirements, services, campus resources, academic expectations and institutional procedures. It also helps students to better understand the college catalog and schedule of classes which are necessary in planning a course of study and educational goals.

COUNSELING INSTRUCTION
(FORMERLY PERSONAL DEVELOPMENT)

818.364.7655 or 818.364.7656

These courses were established to assist students in their quest for success. Covering personal, career, and academic areas, counseling classes introduce concepts geared towards college success and personal fulfillment.

CHILD DEVELOPMENT CENTER

818.364.7865

The campus Child Development Center provides care and education for the children of Mission College student-parents (while they are attending classes) as well as for families in the community. A knowledgeable, licensed, and professional staff provides an educationally enriching and developmentally appropriate program for children from birth through age five. The program is free for parents who qualify or a fee is charged on a sliding scale according to income – from \$1 to \$5 per hour. While student-parents have priority registration, the Center is also open to community families. For hours and other information, contact the Child Development Center.

**DISABLED STUDENTS PROGRAMS
& SERVICES (DSPS)**

818.364.7732

Los Angeles Mission College recognizes and welcomes its responsibility to provide an equal educational opportunity to all disabled individuals. The Office of Disabled Students Programs and Services (DSPS) has been established to provide support services for disabled students pursuing a college education.

Services include registration assistance, academic advisement and program planning, high-tech computer center, alternate media production, electronic access, tutors, classroom notetakers,

recorded texts, instructor liaison, mobility assistance, testing assistance, interpreters, work experience, and the use of special equipment such as tape recorders and a courtesy wheelchair. Special classes are offered in basic skills, personal development, employment skills, study skills, and adaptive kinesiology. Other services may be arranged as needed. However, students are responsible for their own personal care while on campus.

Individuals qualify for Disabled Students Programs and Services by having a current LAMC application on file with the Admissions Office and verifiable documentation of a disability. If documentation is not readily available, the DSPS counselor may send for records with the individual's written permission. A special case may arise in which a learning disability is reasonably suspected, but no previous records are available or exist. In this case, DSPS can administer an assessment to see if the individual qualifies to be served as a person with learning disabilities. If qualified in this way, the individual may access all appropriate DSPS services.

The Office of Disabled Students Programs and Services maintains a liaison with the California Department of Rehabilitation and other public agencies.

Any vehicle parked in a space designated for "Handicapped Only" must display a valid handicapped permit or placard issued by the Department of Motor Vehicles. Disabled individuals with the placard and student-parking permit may park anywhere on campus, in staff/visitor, student, or staff lots. For additional information concerning services for disabled students, please contact the Office of DSPS.

**EXTENDED OPPORTUNITY
PROGRAM & SERVICES (EOPS)**

818.364.7645

EOPS is a program undertaken by Los Angeles Mission College and administered in accordance with state legislation (SB 164 and AB 1030). It is a state-funded program.

Its purpose is to provide positive educational support in order to improve retention, persistence, graduation, and transfer rates to students who may have language and socioeconomic disadvantages and who may be first generation college students. In addition, EOPS strives to facilitate these students' participation in college life and in successfully achieving their educational goals.

EOPS educational support services include in-depth academic counseling, tutoring, peer advising, transfer assistance, including completing university applications in addition to providing application fee waivers, university and cultural field trips, educational survival kits that include school supplies, book vouchers, and cash grants when available.

To be considered for EOPS, students must meet the following minimum requirements:

- A. Be a resident of California pursuant to the provisions of Part 41 commencing with Section 68000 of the Education Code
- B. Qualify to receive a Board of Governors Grant pursuant to Section 58620(1) or (2). (Code A or B)
- C. Be enrolled full-time (12 units or more) when accepted into the EOPS program. Exceptions for disabled students enrolled in less than full-time (must have documentation from LAMC Disabled Student Services Program).
- D. Not have completed more than 50 units of degree-applicable credit course work in any combination of post-secondary higher education institutions

Student Information

E. Be educationally disadvantaged as determined by the EOPS Director or designee. In making that determination, the EOPS Director shall consider one or more of the following factors:

1. Not qualified at the college of attendance for enrollment into the minimum level English or mathematics course that is applicable to the Associate Degree
2. Not have graduated from high school or obtained the General Education Diploma (G.E.D.)
3. Graduated from high school with a grade point average below 2.50 on a 4.00 scale
4. Been previously enrolled in remedial education
5. Other factors as approved by the California Community College Chancellor's Office

COOPERATIVE AGENCIES RESOURCES FOR EDUCATION (CARE)

818.364.7645

The Cooperative Agencies Resources for Education (CARE) program was established in 1982 to provide additional educational support services to Extended Opportunity Programs and Services (EOPS) students who are current recipients of assistance from CalWORKs/TANF/Tribal TANF, are single parents with at least one child under 14 years old at the time of acceptance into the CARE program.

The goal of the program is to provide academically high-risk students with educational support services, as a means of strengthening their retention, persistence, graduation and transfer rates. Supplemental services include counseling, tutoring, peer support, networking with other single parents, and workshops or activities that enhance their personal development and self-esteem. Meal tickets and child-care funding are provided for those who qualify

In order to obtain a CARE application, you first need to apply to the EOPS program.

INTERCOLLEGIATE ATHLETICS

The athletic programs of Los Angeles Community College District provide men and women with an equal opportunity to participate in intercollegiate athletics. The college teams, which include men's soccer and women's volleyball, men's baseball and women's softball, compete in the Western State Conference. Each sport activity is taught by highly qualified instructors, and individual attention is given to each student-athlete. All questions pertaining to athletic programs should be directed to the Director of Athletics.

TRANSFER CENTER

818.364.7827 | www.lamission.edu/transfercenter

The Transfer Center assists students seeking to continue their studies at a four-year college or university. The Transfer Center provides information regarding the application process, opportunities to meet with admissions representatives from four-year schools, a reference library, and workshops on transfer issues. Students are encouraged to begin planning for transfer as early as possible.

VETERAN AFFAIRS PROGRAM

818.364.7864 | www.lamission.edu/vets

Location: Campus Center Lower Level

Los Angeles Mission College academic programs are approved for eligible veterans and their dependents seeking regular and Post 9/11 Educational Benefits provided by The United States Department of Veteran Affairs. The Veterans Resource Center is a central location where Veteran, Reserve, Active Military and Dependents may find resources and receive additional support services.

Those planning to receive VA Educational Benefits should visit the Veteran Affairs Office for assistance with the enrollment and assessment process. Students must schedule an appointment

with the VA counselor to create a Student Education Plan (SEP) and register for courses prior to attaining certification. Those receiving benefits are responsible for observing VA regulations and college policy as they apply to all students. Additional information and forms may be found at the veteran student website.

See page 48 for information regarding "Credit for Military Service Training."

Financial Aid

WHAT IS FINANCIAL AID?

818.364.7648

Financial aid is funding provided by the federal and state governments, the college, and private entities, to assist students with their educational expenses and is available in the form of grants, scholarships, employment and loans. Financial aid is meant to supplement the family's existing resources in funding the costs of a college education.

WHO IS ELIGIBLE?

To be considered for federal and state financial aid, students must generally meet the following minimum requirements:

- Be a U.S. citizen or an eligible noncitizen
- Demonstrate financial need
- Be enrolled as a regular student, making satisfactory academic progress in a course of study leading to a certificate, an Associate degree, or transfer to a baccalaureate degree program
- Not be in default on any federal student loans and not owe a refund of any federal student grants
- Be registered with the Selective Service if required to do so
- Have a valid social security number
- Have a high school diploma, have passed a high school proficiency examination, or have received a certificate of General Education Development (GED).

Financial Aid for AB540 Students

With the passage of state laws AB130 and AB131 (known collectively as the California DREAM Act), students who are classified as "AB540 students" with the campus Admissions & Records Office may be eligible for state financial aid programs (BOG fee waiver and Cal Grants). Students can apply through the California Dream Act application, available online at www.caldreamact.org. All deadlines mentioned in this section regarding the Cal Grant application process are applicable for California Dream Act applicants.

U.S. Department of Education Disclosure Regulations Regarding Programs Leading to Gainful Employment

To qualify for federal financial aid students must declare participation in a program that leads to a degree (associate, bachelor, graduate or professional) or in a certificate program that prepares students for employment. Effective July 1, 2011, the U.S. Department of Education (Federal Regulations 75-FR66832) has established guidelines requiring that community colleges disclose specific information regarding programs that lead to gainful employment in a recognized occupation. Information includes but is not limited to occupational profiles, program costs, employment projections, number of students who complete the program and time to completion of the program. In accordance with these regulations, a website is provided by Los Angeles Mission College which provides this information: www.lamission.edu/careers/programs.aspx

WHAT IS THE PROCESS?

To apply for federal and state financial aid, you need to complete a Free Application for Federal Student Aid (FAFSA) every year of college. The FAFSA can be completed online at www.fafsa.gov. The form is available annually starting January 1st,

for the following academic year. We encourage students to apply early, as some financial aid resources are limited and awarded to students who apply early and have financial need.

Once you have submitted your FAFSA, you will receive your results (known as the Student Aid Report, or SAR). All schools listed on your FAFSA will also receive your results. The Financial Aid Office will send an email to you regarding any documents or forms we need to complete your file.

After your SAR information and any requested items are received and reviewed, the Financial Aid Office will send you an email regarding your Award Offer, with directions on how to view your information through the LACCD online Student Information System (SIS). Information on the SIS will provide you with the details of your financial aid eligibility.

To apply for scholarships through the Financial Aid Office at LAMC, check out our website at www.lamission.edu/financialaid and select the "Scholarships" link.

WHEN TO APPLY

You need to apply for financial aid every year. The FAFSA is available starting January 1st of each year for the following academic year. We encourage students to apply early, as financial aid resources are limited and awarded to students who apply early and have some financial need.

TIMELINE & DEADLINES

Jan 1	FAFSA application available online at www.fafsa.gov for the following academic year.
Mar 2	Application deadline for Cal Grant consideration.
May 1	L.A. Mission College "Priority" deadline. Submit your FAFSA and any follow up documents and items by this date for maximum financial aid consideration.
Sep 2	Extended Cal Grant B "competitive" awards deadline for community college students only.

Additional deadlines and important dates are available on the Financial Aid Office website (www.lamission.edu/financialaid) under "Calendar/Deadlines," and are also included on forms that have specific filing deadlines.

HOW IS FINANCIAL AID AWARDED?

Your financial aid eligibility is determined by using Federal Methodology. In practice, we subtract your Expected Family Contribution (EFC) from your Cost of Attendance (COA) to determine your Need. Your EFC is calculated from the information provided on your FAFSA and is a measure of your (or your family's) ability to pay for college. COA is the estimated allowable expenses related to a year of college (tuition and fees, books and supplies, room and board, personal expenses, and transportation) as determined by a number of factors. Once your Need is calculated, our Office will determine your financial aid awards. Awards can consist of a combination of grants, work-study, scholarships, and student loans.

THE AID AWARD OFFER

Aid Award Offers are posted to the LACCD online Student Information System (SIS) emails sent to students once an offer has been made. The SIS will summarize a student's Cost of Attendance (COA), Expected Family Contribution (EFC), total awards, resources, and unmet need. Students may accept or reject all or parts of their financial aid offer. However, if a student rejects an award, a substitute may not be available. Students may receive revised Aid Award Offers throughout the academic year which may reflect additional fees or allowances added to the cost of attendance, educational resources which must be accounted for, enrollment changes, and additions or deletions of awards.

Financial assistance is considered supplemental to the family's resources, student earnings, and assistance received from other sources. Applicants

Student Information

are reminded that they should NOT depend on financial aid to meet their basic living expenses.

The Financial Aid Office reserves the right to modify aid commitments at any time due to changes in the student's financial status; changes in the availability of funds; or changes in federal, state, Los Angeles Community College District, or institutional policies or regulations. The amounts that appear in an Aid Award Offer are based on full-time enrollment (12 units or more). Should a student decide to take fewer classes, disbursements will be adjusted accordingly.

FINANCIAL AID DISBURSEMENT

Financial Aid funds, in excess of institutional charges covered by financial aid, will be disbursed as either an Electronic Funds Transfer (EFT) to the student's bank account, or as deposit to a Debit Card issued in the student's name.

Additional information about the schedule of disbursements for the academic year will be included with the Aid Award Offer and in supplemental materials sent to the student at the time the Award Offer is made.

Students who have an approved Extension Petition will have their disbursements calculated based on the number of approved units for which they enroll (i.e., units for courses listed on the student's Student Educational Plan and approved by the Financial Aid Office).

CHANGE OF ENROLLMENT STATUS

It is your responsibility to drop your classes through the Admissions and Records office if you do not attend your classes. Failure to drop classes may result in a financial aid overpayment, which may require repayment of financial aid you received. Owing a repayment of financial aid will make a student ineligible for continued receipt of federal and state financial aid until the debt is repaid.

RETIREMENT / SCHOLARSHIP / MCID 6 BDC URN OF TITLE MCID FUNDS

A student who completely withdraws from a period of enrollment (i.e., semester) may incur an overpayment of aid. Federal rules assume that a student "earns" aid based on the length of time the student attended during a given period of enrollment. "Unearned" aid, other than Federal Work-Study, must be returned. The Financial Aid Office will calculate the amount the student owes and notify them of their repayment options. Additional information on this and other policies is available at the Financial Aid Office and at their website, www.lamission.edu/financialaid

It is advised that students contact the Financial Aid Office before withdrawing from all classes to receive guidance as to the effects of withdrawal.

AUDITED CLASSES

Students CANNOT receive financial aid (including the BOG Fee Waiver) for enrollment in audited classes.

CONSORTIUM AGREEMENTS & ITV CLASSES

(Enrollment at other colleges)

Consortium Agreements are in effect for all colleges within the Los Angeles Community College District (LACCD). If you are attending more than one college within the District in the same academic period, payment will be based on all units taken within the district.

If you are attending a college within the District and taking courses at a college outside of the District and you wish to have these courses count toward your total enrollment, you will need to complete a Financial Aid Consortium Agreement form, available through the Financial Aid Office.

Students taking only ITV classes must have their financial aid processed through the LAMC Financial Aid Office. If a student has ITV classes and classes at other LACCD colleges, but is not enrolled at

at the LACCD college they are enrolled through for the specified semester/academic year.

STUDENT RESPONSIBILITIES

Students must take responsibility for the following:

1. For the purposes of reporting Grade Point Average (GPA) information (for Cal Grant consideration) and enrollment information (for loan deferments), a valid social security number (SSN) must be on file in the Admissions and Records Office. For eligible AB 540 students, no SSN is required for the college submit GPA information.
2. Students must maintain satisfactory academic progress to receive financial aid and should meet with an academic counselor to develop or review a Student Educational Plan.
3. Students must submit all financial aid applications and documents by specified deadlines.
4. Students must complete all financial aid forms accurately and completely and submit them to the right place on time.
5. Students are responsible for reading and understanding all financial aid forms and information. We advise students to retain copies of all documents submitted.
6. Students MAY NOT receive financial aid from two or more institutions at the same time or periods of overlapping terms. The only exception to this rule is the BOG (Board of Governors) fee waiver.
7. Students must notify the appropriate entity (college, lender, California Student Aid Commission, U.S. Department of Education, etc.) of changes in your name, address, school enrollment status, or transfer to another college.
8. Intentional misreporting of information on application forms for financial aid is a violation of the law and is considered a criminal offense subject to penalties under the U.S. Criminal

Code and denial of the student's application. Additionally, regulations require that all cases of suspected fraud emanating from misrepresentation be reported to the Office of the Inspector General.

FRAUD

- A student who attempts to obtain financial aid by fraudulent means will be suspended from financial aid eligibility for unsatisfactory conduct.
- The college will report such instances to local law enforcement agencies, to the California Student Aid Commission, and to the federal government.
- Restitution of any financial aid received in such manner will be required.

Types of Financial Aid

FEDERAL FINANCIAL AID PROGRAMS

Federal Pell Grant

The Pell Grant Program is a federally funded program. Pell Grants do not need to be repaid (unless they are part of an overpayment of aid). To be eligible, an applicant must be an undergraduate student who has not earned a bachelor's or professional degree. Pell Grants range from \$400 to \$5,815 (as of the 2016-2017 academic year) per academic year. The amount of the award is based on the results of the student's FAFSA and enrollment level (i.e., full-time, half-time).

Federal Supplemental Educational Opportunity Grant (FSEOG)

The SEOG program is a federal grant program designed to supplement other sources of financial aid for students with exceptional need. FSEOG awards range from \$200 to \$400 per academic year, depending on need and packaging policy constraints.

Federal Work Study Program (FWS)

FWS is a federal program which enables students to earn part of their financial aid award through part-time employment on-campus. FWS is awarded

to students who indicated an interest in student employment through the online Federal Work Study Interest List and who demonstrate financial need. FWS is subject to funding availability.

Federal Student and Parent Loans

Students are in no way obligated to apply for a loan. All loans require a minimum of half-time enrollment.

Los Angeles Mission College participates in the following student loan programs:

1. Federal Perkins Loan Program

The Federal Perkins Loan Program is a low-interest loan to help students with exceptional need meet their educational expenses. Loan amounts awarded are determined by the college and the availability of funds.

Repayment begins nine months after the borrower graduates, withdraws, or ceases to be at least in halftime studies. The repayment period will last no longer than ten years and may be shorter if a small amount has been borrowed. During the repayment period, five percent interest is charged on the unpaid balance of the loan principal.

2. Subsidized Federal/Direct Stafford (Student) Loans

Subsidized Federal Direct Stafford Loans are fixed interest loans made to students who show financial need while attending college at least half-time. Please check with the Financial Aid Office for the current interest rate. Loans are made directly by the US Department of Education. "Subsidized" means the government pays the interest while you are in college. After a six-month grace period, repayment begins.

3. Unsubsidized Federal/Direct Stafford (Student) Loans

Unsubsidized Federal Direct Stafford Loans are non-need based loans that you may be eligible for if your financial need is not met by need-based financial aid programs. The government does not pay interest for you while you are in school, in

deferment status, or during your grace period. For both types of Direct Stafford Loans, an applicant must submit a Loan Request Form and complete the mandatory Loan Entrance Counseling requirement.

4. Federal Direct PLUS (Parent) Loans

The Federal Direct PLUS loan program allows parents with good credit histories to borrow for dependent children who are enrolled at least half-time. These loans are made directly by the US Department of Education. Repayment begins within sixty days after the last disbursement.

STATE FINANCIAL AID PROGRAMS

Board of Governors (BOG) Fee Waiver Program

The Board of Governors (BOG) Fee Waiver program is offered at the California Community Colleges for eligible students who are California residents. The waiver only waives the enrollment fees for the student. Applicants do not need to enroll in a specific number of units or courses to receive the BOG.

Students who have applied for financial aid through the FAFSA and listed Los Angeles Mission College (school code 012550) will automatically be reviewed for BOG eligibility. If they are eligible, a fee waiver will be automatically awarded and the student will be sent a postcard or email.

You are eligible to apply for a waiver if you are a California resident and one of the following statements applies to you.

BOG Type A - At the time of enrollment you are a recipient of benefits through the TANF/CalWORKs, SSI/SSP, or General Assistance programs.

BOG Type B - You meet the state-determined income standards.

BOG Type C - You are qualified for need-based financial aid, as determined by the results of your FAFSA.

Student Information

Special Classifications - There are a number of special classifications which may qualify you for BOG eligibility. Documentation or certification must be submitted for consideration. To find out if you meet one of these classifications, download the BOG Fee Waiver application form from the Financial Aid Office website: www.lamission.edu/financialaid

Cal Grant Program

Cal Grants are the largest source of free money or college from the state and are administered by the California Student Aid Commission (CSAC). Students must meet the basic requirements for state and federal aid for consideration. Students must also meet the following additional eligibility requirements:

- Submit the FAFSA and verified Cal Grant GPA by March 2nd
- Be a California resident
- Be attending at least half-time
- Have family income and assets below established income and asset ceilings
- Have not already earned a bachelor's or professional degree before receiving a Cal Grant

Deadline Date: The first deadline is March 2nd. A second deadline for community college applicants is September 2nd, but we highly recommend that applicants meet the March 2nd deadline as more funding is available. Students must also submit the FAFSA by the deadline date to apply for the Cal Grant. Students must submit their GPA verification to the California Student Aid Commission. GPA verification for students enrolled within LACCD will be electronically sent to the Commission before the deadline date for those who meet specific criteria. Please check with the Financial Aid Office to see if you meet the criteria to have your GPA electronically sent and for other possible options.

Cal Grant B

At community colleges, students may be eligible to receive up to \$1,656 per academic year (2015-2016 academic year amount)

Cal Grant C

Cal Grant C is for students in occupational or career training programs who are from low-income and middle-income families.

Applicants who demonstrate financial need will be sent the Cal Grant C Supplement to complete as part of the process. At community colleges, students may be eligible to receive up to \$576 per year (2015-2016 academic year amount).

Child Development Grant Program

The Child Development Grant Program is for students who plan to teach or supervise at a licensed children's center. The grant is renewable for an additional year. For more information about this program, you may call the California Student Aid Commission at 888.224.7268, E-mail: specialized@csac.ca.gov or visit the website at www.csac.ca.gov

Chafee Grant

The Chafee Grant provides grant money to foster youth and former foster youth to use for college courses or vocational school training. Eligible students may receive up to \$5,000 per academic year. For more information and to apply, you must complete the FAFSA and complete a California Chafee Grant Program Application available at their website: www.chafee.csac.ca.gov

SCHOLARSHIPS

Scholarships are gift-aid awarded on the basis of merit, academic excellence, and in some cases, additional criteria such as study in a particular major, leadership, or financial need. Please visit the Financial Aid Office for scholarship listings, or visit our webpage: www.lamission.edu/financialaid

Financial Aid Satisfactory Academic Progress Policy

To be eligible for federal and state financial aid programs, students are required by the U.S. Department of Education and the State of California to maintain satisfactory academic progress (SAP) as they work toward completing their educational objective - certificate, Associate degree, or transfer program. The Los Angeles Community College District (LACCD) has established guidelines to promote timely completion of its educational programs, which is applied to all classes taken in the LACCD.

Programs governed by the SAP policy

SAP policy include: Federal Pell Grant, Iraq and Afghanistan Service Grant, Federal Supplemental Educational Opportunity Grant (FSEOG), Federal Work-Study (FWS), Federal Perkins Loan, Federal Nursing Loan, Federal Direct Stafford (student) and PLUS (parent) Loans, Cal Grants (B & C), Child Development Grant, California Chafee Grant, and the California National Guard Education Assistance Award Program. The Board of Governors (BOG) fee waiver is exempt from these SAP requirements.

Who is affected by the SAP policy?

All students who apply for, receive, and/or wish to receive financial aid are affected by the SAP policy and requirements.

All students are monitored for Satisfactory Academic Progress at the end of each payment period (Summer, Fall/Winter, and Spring comprise our payment periods). Federal guidelines require that we count all classes even if a student was not receiving financial aid at the time they were enrolled. Units from all semesters and terms are counted and evaluated. Also, all units taken outside the LACCD and reported to any LACCD Admissions & Records Office will be counted toward a student's

total Attempted Units when determining SAP status.

Satisfactory Academic Progress Standards

- Maintain a cumulative Grade Point Average (GPA) of 2.00 or higher
- Successfully complete a minimum of 67% of all units attempted
- Have less than ninety (90) attempted units
- Have not earned an AA, AS, or higher degree outside of the LACCD

Application of Standards

Warning letters are sent to students who were initially in good standing but now have a cumulative GPA less than 2.0 and/or their cumulative non-grades are greater than 33%. Students who receive Warning letters should see an academic counselor as soon as possible.

Advisory letters are sent to students after the end of the semester when the number of units attempted reaches or exceeds forty-five (45). Again, you should see an academic counselor to make sure you are taking the classes you need to reach your educational goal before you reach the 90 attempted unit maximum.

Disqualification letters are sent to students if they continue to not meet the GPA or passing percentage requirements after the semester in which they received a Warning letter. Disqualification letters are also sent to students after they exceed 89 attempted units or they have earned an Associate degree or higher outside of the LACCD. Students receiving a Disqualification letter are no longer eligible for financial aid (other than a BOG fee waiver) in the LACCD.

Additional information on the SAP policy and process at LAMC is available through the Financial Aid Office and their website at www.lamission.edu/financialaid. Information regarding the petition process, timeline, and deadlines is available through the Financial Aid Office and their website.

Special Programs

NON-CREDIT PROGRAM

818.364.7774

The Non-Credit Program offers classes that are designed to provide opportunities for personal enrichment, enhancement of job opportunities orientation for a college career and preparation to successfully pass the GED or CAHSEE exams. Our instructors are trained in their fields and committed to providing our students with the best education.

GED Preparation Services

The General Education Development (GED) certificate is widely accepted as an equivalent to a high school diploma. The certificate is earned by passing five official GED tests in the areas of writing, reading, social studies, science and mathematics. Getting a GED certificate can make a big difference in a student's ability to get and keep a job or to qualify for further education. Prior to enrollment each student is assessed in the areas of math and English and placed into a class that best fits their needs. We offer free preparation classes that focus on all subjects tested by the GED exam. We do not offer the GED test at our location but our program will monitor the progress of each student and help them with the registration process and a convenient location to take the test.

English as a Second Language (ESL) Classes

Our ESL-NC program is designed to help our students speak, read and write English. We offer free courses that focus on conversation, reading and beginning grammar. Each student is assessed and placed into a class that best fits their needs. We offer free counseling services that help monitor the progress of each student; they also help with the transition into higher level credit ESL classes on campus.

Citizenship Test Preparation Classes, Evaluation of Form N-400 and Naturalization Assistance Services

During the naturalization eligibility interview, a USCIS Officer tests each applicant on the ability to read, write, and speak English (unless the applicant is exempt from the English requirements). Our program offers preparation for the civics test; we coach each student in the interview process, and teach them about U.S. history and government. Our classes are designed to help the student successfully pass the reading, writing and speaking tests. We also have services to help complete the N-400 form and to answer any questions regarding the process.

For more information about the Non-Credit program, call 818.833.3355 or log onto www.lamission.edu/noncredit

INSTRUCTIONAL TELEVISION (ITV) THE WEEKEND COLLEGE

818.833.3594 | www.lamission.edu/itv

Each semester the ITV/The Weekend College program of the Los Angeles Community College District offers college classes that meet general education and transfer requirements using a blended format of video lessons, online activities, and weekend class meetings. The classes are offered in five 8-week sessions.

ITV/The Weekend College classes are convenient, flexible, and especially suitable for working adults and college students wanting to supplement their on-campus program when campus attendance is not possible. Students complete reading and study assignments, watch video lessons broadcast on cable television or video streaming or on DVD, attend classes on weekends at a Los Angeles Community College near their home, and complete midterm and final examinations.

A Los Angeles Community College instructor is assigned to assist students in each class. It is

Student Information

advisable to meet with your counselor to ensure that you choose classes that meet your needs. For additional information, contact ITV in the Campus Center, Room 1528.

INTERNATIONAL EDUCATION PROGRAM - STUDY ABROAD CLASSES

213.891.2390 | www.laccd.edu

College credit classes are offered by the International Education Program with instructors and classes selected from the nine Los Angeles Community Colleges. Programs are offered in more than a dozen countries around the world. Opportunities for study include Spanish Language and Civilization; Art in Mexico, Spain, and Costa Rica; Creative Writing in Prague and Dublin; French, French Civilization and Art in Paris; Italian, Italian Civilization and Art in Florence; Marine Biology in Mexico; Theater in England; Business in China; Chinese Civilization and Chinese Language in China; and Art in Bali. Partnership programs are being established with overseas colleges and universities; international distance-learning programs are beginning to appear. Students may spend a semester in Salamanca, Spain; Paris, France; Florence, Italy; or London, England. Work-study programs are available in London, Paris, and Madrid. A program of cooperation has been arranged with Barnsley College in England for music students at Los Angeles Pierce College and theater students at Los Angeles Harbor College. On-site investigation of the history and cultures of other nations provides students and their instructors with some of the best educational experiences of their lives. The International Education Program demonstrates the commitment of Los Angeles Mission College to furthering development of international and intercultural awareness.

Student Activities

Cocurricular or extra class activities are intended to provide students with the opportunity to be better prepared to fulfill the duties of citizenship in a democratic society and to enrich their educational and personal development. This may be accomplished through extra class cultural activities; volunteer programs related to the instructional program; and participation in community-related affairs, athletics, and student government. Students who learn to work with groups will develop leadership skills to prepare them for cooperative and meaningful associations in both occupational and personal pursuits.

The development of a student activity program is a vital portion of the obligations that both faculty and administrators assume for students in any American college community. At Los Angeles Mission College, student activities are an integral part of the educational program.

ASSOCIATED STUDENTS ORGANIZATION

818.364.7600 x7120 | www.lamission.edu/aso

The Associated Students Organization (ASO) is open to all current students of Los Angeles Mission College. All students are welcomed and urged to participate. The Associated Students Organization provides a framework for many college student activities. Through active participation in student government and clubs, the student renders service, increases social and cultural awareness, improves leadership abilities, and creates a close association with other students. Students are encouraged to serve on campus and ASO committees.

Membership in the Associated Students Organization of Los Angeles Mission College is \$7 per semester and \$3 per summer and intersession. For more information, visit the Student Activities Office in the Campus Center, or visit the ASO website.

QUALIFICATIONS FOR ASO OFFICERS

Administrative Regulation E-22

Administrative Regulation E-22 pertains to all officers of the Associated Students Organization. Administrative Regulation E-22 does not apply to clubs, club representatives, ASO special committees and all-college committees, or student trustees.

1. As defined by the ASO constitution and by-laws, the following standards governing candidate and officer eligibility for appointed and elected Associated Students Organization officers (ASO) must be met:
 - a. The candidate or officer must be a currently paid member of the ASO at the college where the election is being held and have successfully completed no more than 80 degree-applicable units in the District.
 - b. The candidate may seek only one campus office within the District.
 - c. The candidate or officer must have and maintain a cumulative and current GPA of at least 2.00 in units completed at all the colleges in the District during the semesters in which the student government office is applied for and held. Current means the most recently completed semester or session.
 - d. The candidate or officer must not be on academic or progress probation. Progress probation is defined as having recorded grade entries of "W" (Withdrawal), "INC" (Incomplete) or "NC" (No Credit) for fifty percent or more of all units in which a student has enrolled. Academic probation results when a student fails to maintain an accumulated grade point average of 2.00.
 - e. At the time of election or appointment and throughout the term of office, the candidate or officer must be actively enrolled in and must successfully complete a minimum of six (6)

- units per semester. Students falling below this requirement will automatically forfeit their office. Candidates may be enrolled in more than one college in the District, but the candidate must be currently enrolled in a minimum of six (6) units at the college where the candidate is seeking office. Officers must maintain that enrollment at the college where the office is held.
- f. Exceptions on the maximum unit requirement in Section 1a of this regulation may be made for students enrolled in a college degree, certificate or transfer program where the combination of program requirements and prerequisites may result in the student exceeding the 80 degree-applicable unit limit. Exceptions will be decided by the College President based upon recommendations made by the Chief Student Services Officer. To be considered for an exemption, a student who exceeds the 80 degree-applicable unit maximum must satisfy at least one of the following conditions:
- i. The requirements of the student's declared Associate Degree major, certificate and/or transfer objective, as specified in the college catalog, caused the student to enroll in courses that exceeded the 80 degree-applicable unit maximum.
 - ii. Program prerequisites, as specified in the college catalog, caused the student to exceed the 80 degree-applicable unit maximum.
2. A candidate or officer is ineligible for ASO office in the following cases:
- a. If he or she has served more than four (4) semesters in any one (1) or more student government-elected or appointed offices in the District.
 - b. If a candidate or officer, who exceeded the unit maximum in Section 1a of this regulation and was granted an exception, fails to be enrolled in courses that are specifically required for his or her declared Associate Degree, certificate, or transfer objective requirements as specified in the college catalog.
 3. An officer may serve a fifth semester if eligible at the time of assuming office with the approval of the college president or designee (e.g., he or she has served three semesters and is a candidate for an office with a one-year term).
 4. The Chief Student Services Officer and/or designee will verify a candidate's or officer's eligibility. If the student should disagree with the findings of the Chief Student Services Officer and/or designee, he or she can appeal the decision through the student grievance procedures contained in LACCD Administrative Regulation E-55. Officers not adhering to the standards for office will be required to forfeit their positions.
 5. Candidates or officers must comply with the minimum standards of the District Code of Conduct. Failure to comply will result in forfeiture of the position (Board Rule, Article VIII, Sections 9801-9806).
 6. Any candidate or officer with a disability may request an accommodation for the requirements of Section 1e:
 - a. The approval of the accommodation for candidates with a disability will be made in individual instances on a case-by-case basis by the Chief Student Services Officer in consultation with the college Compliance Officer and/or the Director of the Disabled Students Programs and Services (DSPS) in compliance with Section 504 of the Rehabilitation Act and Title II of the Americans with Disabilities Act, as appropriate.
 - b. Qualification for an accommodation will be based on the impact of the disability on the candidate's or officer's ability to take six units. However, a candidate or officer must be enrolled in a minimum of five units throughout his or her term in accordance with Education Code Section 76071.
 - c. Procedures for requesting an accommodation under E-22:
 - 1) Candidates or officers must complete a written request form for accommodation available in the college's Student Services Office and return it to the Chief Student Services Officer.
 - 2) Each candidate or officer must present written documentation verifying the disability. Acceptable documentation includes, but is not limited to, written notice from the college DSPS office or a certified or licensed professional, such as a doctor, psychologist, rehabilitation counselor, or occupational or physical therapist.
 7. Students enrolled in college credit and/or non-credit courses are eligible to vote at the college of attendance. Enrollment in Community Services classes does not meet this requirement.
 8. Individual colleges may set forth standards for office in their ASO constitutions which are higher, but not lower, than those listed above with the exception of the accommodations listed in Section 6 above.
- For further information, contact the Office of Student Services 818.364.7766.

STUDENT CLUBS & ORGANIZATIONS

Student clubs and organizations provide a variety of cultural, community, and vocational opportunities. Service clubs, special-interest clubs, department-related organizations, and religious clubs offer a variety of opportunities for student involvement. Students will find their college experience more meaningful and valuable through active participation in some social or extracurricular activity of the college program. Any group wishing to become a recognized L.A. Mission College organization must submit a constitution and be approved by the Associated Students Organization Executive Council.

Student Information

STUDENT TRUSTEE ELECTION PROCEDURE

The Los Angeles Community College District conducts an election annually whereby each student in the District has an opportunity to be involved in the process of selecting a student representative to the Los Angeles Community College District Board of Trustees. The process described in Regulation E-78 provides for a thorough evaluation of the candidates' qualifications and ensures an equal opportunity for any individual from any District college to seek the position of student representative to the Los Angeles Community College District Board of Trustees. In accordance with existing law, candidates for Student Trustee must meet the following criteria:

- A. Be currently enrolled and in good standing (i.e., not on academic or progress probation) at one or more colleges in the District
- B. Be currently enrolled in 5 units
- C. Have completed a minimum of 12 units in the Los Angeles Community College District and a maximum of 80 transferable units of college work within the Los Angeles Community College District. Exceptions on the maximum units requirement may be made for students enrolled in Los Angeles Community College District degree, certificate, or transfer programs where the combination of program requirements and prerequisites may result in the student exceeding the 80 transferable unit limit. Exceptions will be decided by the Chancellor or designee based upon recommendations made by the Chief Student Services Officer or designee at the student's primary college of attendance. In order to be considered for an exemption, a student who exceeds the requisite 80 transferable unit maximum must satisfy at least one of the following conditions:

1. The requirements of the student's declared Associate Degree major, certificate and/or transfer objective, as specified in the catalog at the student's primary college of attendance, caused the student to enroll in courses that exceeded the 80 transferable unit maximum.
2. Program prerequisites, as specified in the catalog at the student's primary college of attendance, caused the student to exceed the 80 transferable unit maximum.
3. A returning student who has already completed a college degree or certificated is enrolled in courses that are specifically required for the student's declared certificate, Associate Degree or transfer objective, as specified in the catalog at the student's primary college of attendance.

For further information, contact the Office of Student Services 818-364-7820.

COLLEGE COLORS & THEME

The students, faculty, and staff of Los Angeles Mission College have selected desert blue (PMS281) and silver (PMS430) as the school colors, and the eagle as its mascot. These selections signify the quest for knowledge and pioneering enthusiasm of purpose, which are intrinsic values in a college.

Honors Program

UCLA HONORS TRANSFER ALLIANCE PROGRAM (TAP)

The Los Angeles Mission College UCLA Transfer Alliance/Honors Program (TAP) is designed for motivated students who plan on transferring to a four-year college or university. It consists of academically enriched general education courses in which both written expression and the critical analysis of ideas are stressed. The TAP program offers participating students priority admissions to UCLA and additional opportunities at other universities. Both current and new students may

apply to be part of the TAP program.

Honors program students receive -

- Priority admissions consideration to several prestigious four-year institutions, including UCLA. Admittance rates for UCLA (tabulated for Fall 2011) for TAP/Honors students was 74.3% versus 27.5% for non-TAP/Honors students!
- An enriched academic program allowing students to gain opportunities to pursue topics and projects of individual interest within courses taken; opportunity to gain valuable critical thinking, research and writing skills; opportunities to explore interdisciplinary approaches to course topics
- Assistance in the transfer process
- UCLA Library Card
- Transcripts that reflect participation in the program
- Participation in TAP/Honors allows you to have a non-impacted Alternative Major Selection at UCLA
- A "fast pass" into the bookstore during the first week of each semester
- Regular opportunities for interaction with faculty mentors and program director
- Individualized counseling with an Honors Counselor
- Opportunity to attend the annual Honors Students research Conference at UC Irvine and the TAP/Transfer Conference at UCLA

Program Participation - Students will complete five honors courses with a "B" or better on the Honors project and in the UC transferable class, and honors designation will appear on students' transcripts. For each honors course, students will complete a research project or paper designed in collaboration with the Honors Director Dr. Mike Fenton, and the faculty mentor teaching the course.

Current LAMC students must be eligible for English 101 and have completed 12 transferable units with a GPA of 3.25 or higher. Must be in the

Honors Transfer Program at least one year prior to transferring.

Entering students must have a high school GPA of 3.50 or higher or an SAT score above 1,000, and English placement tests must indicate eligibility for English 101 or higher.

Applying to the Honors Program - These are general guidelines. If you do not meet a specific requirement but would like to be able to participate in TAP, please write to Dr. Mike Fenton at fentonms@lamission.edu to discuss your particular situation.

Completing an Honors Contract - Students receive Honors credit by completing an Honors contract in any UC transferable course. In consultation with the Honors program, department and course instructor (mentor), the student develops a proposal for an Honors research project. In most cases, the project should be a written assignment that displays interpretation, critical analysis, and creative thinking of academic texts (journal articles or books written by experts in an academic discipline). The proposal is evaluated and graded by the mentor submitted to the Honors coordinator and evaluated by the Honors Director. The project will either be approved or returned with suggested revisions. When the final project is completed, the student must submit one copy to the instructor and a second copy to the Honors Coordinator along with an Honors Contract Completion form. This will result in an Honors notation on his or her transcript indicating that the course was completed for Honors credit.

Honors Certification - Students receive Honors certification by completing a total of five Honors contracts (minimum of 15 UC transferable units) and maintaining a minimum 3.25 overall transfer GPA.

For more information and to apply -

- Honors Coordinator: Dr. Mike Fenton, 818.364.7888
- Honors Counselor: Mr. Afri Walker, 818.364.7647
- www.lamission.edu/honors/default.aspx

ADDITIONAL HONORS TRANSFER AGREEMENTS

The Honors Transfer Council of California was created to promote academic excellence, to stimulate creative intellectual thinking and discussions of academic issues among students and faculty, to increase awareness of current social issues, to encourage community service, to celebrate cultural diversity, and to prepare students for successful university transfer.

Transfer agreements may be viewed at www.honorstcc.org, and include agreements with UCI, Occidental College, Chapman University, Pomona, La Sierra University, Whitman College, CSU Fullerton, San Diego State, Azusa Pacific University, Pitzer College, Loyola Marymount University, Mills College, Whittier College, and University of San Diego. Please go to www.honorstcc.org and view the agreements page where information on specific benefits of agreements with each school are listed (www.honorstcc.org/transfer/HTCC_Agreements.pdf).

Call Counseling 818.354.7655 or 818.364.7656 to meet with a counselor and to plan meeting the honors course requirements for these programs.

Standards of Student Conduct and Disciplinary Action

The Standards of Student Conduct and Disciplinary Action for violation of rules were established by the Board of Trustees of the Los Angeles Community College District on September 2, 1969. A student enrolling in one of the Los Angeles Community Colleges may rightfully expect that the faculty and administrators will maintain an environment in which there is freedom to learn. This requires that there be appropriate conditions and opportunities in the classroom and on the campus. As members of the college community, students should be encouraged to develop the capacity for critical judgment, to engage in a

sustained and independent search for truth, and to exercise their rights to free inquiry and speech in a responsible, non-violent manner. Students shall respect and obey civil and criminal law and they shall be subject to legal penalties for violation of laws of the city, county, state, and nation. Student conduct in all of the Los Angeles Community Colleges must conform to District and college rules and regulations.

Violations of such rules are subject to the following types of disciplinary actions, which are to be administered by appropriate college authorities against students who stand in violation. Each of the Los Angeles Community Colleges shall establish due process of law for administration of the penalties enumerated here. Penalties are listed in degree of severity but not as chronological administration. College authorities will determine which type of penalty is appropriate.

1. **WARNING** - Notice to the student that continuation or repetition of specified conduct may be cause for other disciplinary action.
2. **REPRIMAND** - Written reprimand for violation of specified rules. A reprimand serves to place on record that a student's conduct in a specific instance does not meet the standards expected at the college. A person receiving a reprimand is notified that this is a warning that continued conduct of the type described in the reprimand may result in formal action against the student.
3. **REMOVAL BY INSTRUCTOR** - An instructor may remove (suspend) a student from his or her class for the day of the incident and the next class meeting. During this period of removal, a Summary Investigation should take place as to determine the length of the suspension. Any classes missed during this process will be considered excused absences.
4. **DISCIPLINARY PROBATION** - Exclusion from participation in privileges or extra-curricular college activities set forth in the notice of disciplinary probation for a specified period of

Student Information

time. The imposition of disciplinary probation involves notification in writing of the reason for disciplinary probation to the student(s) or president of the student organization involved.

5. **RESTITUTION** – Reimbursement for damage or for misappropriation of property. Reimbursement may take the form of appropriate service to repair or otherwise compensate for damage.
6. **SUMMARY SUSPENSION** – A Summary Suspension is for purposes of investigation. It is a means of relieving the tension of the student body or individual class due to a serious infraction of student behavior standards, removing a threat to the well-being of the students, or removing for the good order of the college a student or students whose presence would prevent the continued normal conduct of the academic community. Summary Suspension is limited to that period of time necessary to insure that the purposes of the Summary Suspension are accomplished, and in any case, no more than a maximum of 10 school days. Summary Suspension is a type of suspension other than that ordinarily invoked by the instructor in the classroom. The College President, appropriate administrator, or other staff member designated by the President may summarily suspend a student when he deems it necessary for the safety and welfare of the college.
7. **DISCIPLINARY SUSPENSION** – Disciplinary Suspension follows a hearing based on due process of law. It shall be invoked by the College President, appropriate administrator, or other staff member designated by the President, upon students for misconduct when other corrective measures have failed or when the seriousness of the situation warrants such action.
8. **EXPULSION** – An expulsion is a long-term or permanent denial of all campus privileges including class attendance. The President of the

college and/or the Board of Trustees may expel a student who has been convicted of a crime arising out of a campus disturbance or, after a hearing by a campus body, has been found to have willfully disrupted the orderly operation of the campus. The President shall submit periodic reports on all expulsion cases to the Superintendent and the Board of Trustees.

Violations of the Standards of Student Conduct are as follows:

- 2419 Smoking/Nonsmoking Policy:** The Chancellor shall adopt regulations to prohibit the smoking of tobacco, plant, or processed substance, or the use of comparable, personal, vapor-generating devices in the District's buildings, offices, and any other enclosed spaces throughout the District, and limit such activity to a maximum of four locations on any campus.
- 2420 Gun-Free Campuses:** Possession or display of firearms of any kind shall not be allowed on the principal campuses of the District except by law enforcement officials, for theatrical performances, or by others that may have been issued a license or permit that allows the possession of a firearm on campus. This prohibition shall apply even where a firearm is not operational.
- 9803.10 Willful Disobedience:** Willful disobedience to directions of college officials acting in the performance of their duties.
- 9803.11 Violation of College Rules and Regulations:** Violation of college rules and regulations, including those concerning student organizations, the use of college facilities, or the time, place, and manner of public expression or distribution of materials.
- 9803.12 Dishonesty:** Dishonesty, such as cheating or knowingly furnishing false information to colleges.
- 9803.13 Unauthorized Entry:** Unauthorized entry to or use of the college facilities.

9803.14 College Documents: Forgery, alteration, or misuse of college documents, records, or identification.

9803.15 Disruption of Classes or College Activities: Obstruction or disruption of classes, administration, disciplinary procedures, or authorized college activities.

9803.16 Theft of or Damage to Property: Theft of or damage to property belonging to the college, a member of the college community, or a campus visitor.

9803.17 Interference with Peace of College: The malicious or willful disturbance of the peace or quiet of any of the Los Angeles Community Colleges by loud or unusual noise, or any threat, challenge to fight, fight, or violation of any rules of conduct as set forth in this Article.

9803.18 Assault or Battery: Assault or battery, abuse, or any threat of force or violence directed toward any member of the college community or campus visitor engaged in authorized activities.

9803.19 Alcohol and Drugs: Any possession of controlled substances which would constitute a violation of Health and Safety Code Section 11350 or Business and Professions Code Section 4230; any use of controlled substances the possession of which are prohibited by same, or any possession or use of alcoholic beverages while on any property owned or used by the District or colleges of the District. "Controlled substances," as used in this section, includes, but is not limited to, the following drugs and narcotics:

- a. Opiates, opium, and opium derivatives
- b. Mescaline
- c. Hallucinogenic substances
- d. Peyote
- e. Marijuana
- f. Stimulants and depressants
- g. Cocaine

9803.20 Lethal Weapons: Possession, while on a college campus or at a college-sponsored function, of any object that might be used as a lethal weapon is forbidden by all persons except sworn peace officers, police officers, and other government employees charged with policing responsibilities.

9803.21 Discriminatory Behavior: Behavior while on a college campus or at a college-sponsored function inconsistent with the District's non-discrimination policy, which requires that all programs and activities of the Los Angeles Community College District be operated in a manner which is free of discrimination on the basis of race, color, natural origin, ancestry, religion, creed, sex, pregnancy, marital status, sexual orientation, age, handicap, or veteran status.

9803.22 Unlawful Assembly: Any assemblage of two or more persons to do an unlawful act, or do a lawful act in a violent, boisterous or tumultuous manner.

9803.23 Conspiring to Perform Illegal Acts: Any agreement between two or more persons to perform an illegal act.

9803.24 Threatening Behavior: A direct or implied expression of intent to inflict physical or mental/emotional harm and/or actions (such as stalking) that a reasonable person would perceive as a threat to personal safety or property. Threats may include verbal statement, written statements, telephone threats or physical threats.

9803.25 Disorderly Conduct: Conduct that may be considered disorderly includes lewd or indecent attire, behavior that disrupts classes or college activities, breach of the peace of the college, or aiding or inciting other persons to breach the peace of college premises or functions.

9803.26 Theft or Abuse of Computer Resources: Theft or abuse of computer resources including but not limited to the following:

- a. Unauthorized entry into a file to use, read, or change the contents or for any other purpose
- b. Unauthorized transfer of a file
- c. Unauthorized use of another individual's identification or password
- d. Use of computing facilities to interfere with the work of a student, faculty member, or college official or to alter college or District records
- e. Use of unlicensed software
- f. Unauthorized copying of software
- g. Use of computing facilities to access, send, or engage in messages which are obscene, threatening, or defamatory; present a clear and present danger; violate a lawful regulation; and/or substantially disrupt the orderly operation of a college campus
- h. Use of computing facilities to interfere with the regular operation of the college or District computing system

9804 Interference with Classes: Every person who by physical force willfully obstructs or attempts to obstruct any student or teacher seeking to attend or instruct classes at any of the campuses or facilities owned, controlled, or administered by the Board of Trustees of the Los Angeles Community College District, is punishable by a fine not exceeding five hundred dollars (\$500) or imprisonment in a county jail not exceeding one year, or by both such fine and imprisonment.

9805 Interference with Performance of Duties of Employees: Action to cause, or attempt to cause, any employee of the District to do, or refrain from doing, any act in the performance of his or her duties by means of a threat to inflict any injury upon any person or property.

9805.10 Assault or Abuse of an Instructor: Assault or abuse of any instructor employed by the District in the presence or hearing of a community college student, or in the presence of other community college personnel or students, and at a place which is on District premises or public sidewalks, streets, or other public ways adjacent

to school premises, or at some other place where the instructor is required to be in connection with assigned college activities.

9806 Unsafe Conduct: Conduct which poses a threat of harm to the individual and/or to others. This includes, but is not limited to, the following types of conduct: unsafe conduct in connection with a Health Services Program (e.g., Nursing, Dental Hygiene, etc.); failure to follow safety direction of District and/or college staff; willful disregard of safety rules as adopted by the District and/or college; negligent behavior which creates an unsafe environment.

Academic Affairs

THE LEARNING CENTER (TLC)

818.364.7756 | www.lamission.edu/learningcenter
The Learning Center is a hub of activities designed to support student success. Our tutors and staff welcome the opportunity to assist students on their path to success by providing free academic support services to all students. Currently, the Center is comprised of the Academic Success Center, the Learning Lab, and the Math Lab. Students may access one-on-one and group tutoring as well as additional academic assistance for various college skills and subject areas including English, ESL, Literacy, Developmental Communications, and Mathematics. The tutoring staff includes peer tutors, graduate students, and professionals. Students may choose tutor assisted tutorial labs or may choose self-paced learning software. Walk-in workshops are offered periodically on areas such as critical thinking skills, study and test taking skills, essay writing, and computer literacy. The Learning Center also houses the Print Center and Computer Commons with 126 computers with internet access. Specialized software and hardware accommodate students with disabilities. For more information please contact our staff in person or visit the Learning Center online at lamission.edu/learningcenter

Student Information

LIBRARY – AN INSTRUCTIONAL SERVICE

818.364.7600 x7106 | www.lamission.edu/library

As the informational heart of Los Angeles Mission College, the library encompasses a wide variety of materials and services planned to meet the curricular needs of students and to provide facilities conducive to college study.

The Library maintains a collection of books, reference materials, magazines, newspapers, and reserve materials, videos and DVDs and provides individual study areas and group study rooms.

Computers located in the library provide access to word processing, the Internet, research databases, and study aids. Students can access most of this information from home through the library website.

The library staff welcomes your questions and suggestions. A reference librarian is available at all times to help with information needs and to provide instruction in the use of the library either to groups or individuals. Workshops scheduled throughout the semester provide students with instruction on how to do research and how to use computer resources.

The Library has been developed to support and enhance the instructional program of the College. Students are urged to make maximum use of its resources; the staff is eager to assist them.

Title V Programs

TITLE V STRENGTHENING HSI PROGRAM -IMPROVING STUDENT SUCCESS & ACCESS (LRC/ISSA)

818.364.7778

The Title V HSI Program-Improving Student Success and Access (LRC/ISSA) is a five-year program funded by the U.S. Department of Education and is designed to increase the College's capacity to support, retain and successfully transfer a greater proportion of Hispanic and other minority students

to four-year colleges and universities. The LRC/ISSA is comprised of three components, each proposing strategies designed to increase the capacity of L.A. Mission College to support, retain, and successfully graduate a greater proportion of Hispanic Students while strengthening the Learning Resource Center. The components are as follow:

1. Strengthening Academic Support for English, Developmental Communication, and ESL;
2. Strengthening Academic Support for Science;
3. Increase Access, especially for part-time, evening, weekends, and online students.

STEM PROGRAM

818.833.3425 | www.lamission.edu/stem

The LAMC STEM Program is made possible by a five-year grant (2011-2016) by the U.S. Department of Education. It serves as the hub for STEM faculty and students, strengthening academic services:

STEM Program Objectives:

- Offering STEM Summer Academy to incoming STEM majors
- Supporting curriculum development in math, life science, physical science and computer science
- Creating accelerated Math and Science series for STEM students
- Offering internships in industry and academia
- Development of mentoring program
- Development of seminar series
- Enhancing Technology in STEM classes

Benefits of Being a STEM Program Student:

- A scholarly community that provides support and mentoring opportunities
- Participation in the Summer Academy for Math and Sciences
- Priority enrollment in STEM funded Math and Science courses
- Provides free math and science tutoring

STEM CHART

ANATOMY	Course #
Introduction to Human Anatomy	Anatomy 101
ANTHROPOLOGY	Course #
Human Biological evolution	Anthro 101
Human Ways of Life: Cultural Anthropology	Anthro 102
Human Language & Communication	Anthro 104
Anthropology of Religion, Magic & Witchcraft	Anthro 121
ASTRONOMY	Course #
Elementary Astronomy	Astron 1
Fundamentals of Astronomy Laboratory	Astron 5
BIOLOGY	Course #
General Biology I	Biology 6
General Biology II	Biology 7
General Microbiology	Micro 20
CHEMISTRY	Course #
Fundamentals of Chemistry I	Chem 51
Introductory General Chemistry	Chem 65
General Chemistry I	Chem 101
General Chemistry II	Chem 102
COMPUTER SCIENCE INFORMATION TECHNOLOGY	Course #
Introduction to Computers & Their Uses	Co Sci 401
Programming Logic	Co Sci 407
Beginning Computer Architecture and Organization	Co Sci 416
Intro to Data Structures	Co Sci 436
Programming in C++	Co Sci 440
Programming in Java	Co Sci 452
MATHEMATICS	Course #
Trigonometry	Math 240
Pre-Calculus	Math 260
Calculus with Analytic Geometry I	Math 265
Calculus with Analytic Geometry II	Math 266
Calculus with Analytic Geometry III	Math 267
Linear Algebra	Math 270
Methods of Discrete Mathematics	Math 272
PHYSICS	Course #
General Physics I	Physics 6
General Physics II	Physics 7
Physics For Engineers and Scientists I	Physics 37
Physics For Engineers and Scientists II	Physics 38
Physics For Engineers and Scientist III	Physics 39
PHYSIOLOGY	Course #
Introduction to Human Physiology	Physiol 1

- STEM academic counseling that provides education plans and time management plans as well as transfer and career advisement
- Participation in the STEM activities (academic trips, fairs, and clubs)
- May be eligible to participate in Undergraduate Research internships in academia and industry

Student Tracks for the STEM Program

PRE-STEM STUDENT

- Recruit from high school through outreach program(s)
- Students that shows interest in STEM fields determined through counseling
- Student that has not taken a minimum of 2 defined STEM classes (see STEM chart on next page)
- Minimum overall high school GPA 2.5 or college GPA 2.5

STEM STUDENTS

- Students from the local area whose home school may or may not be LAMC
- Students that take STEM courses on the STEM chart and have declared a STEM major
- Students that take STEM funded courses and fill out a STEM funded course application (see college catalog for requirements and application)

PROB-STEM STUDENT TRACK 1

- Has completed two or more STEM courses on STEM Chart
- GPA requirement 2.5 in STEM courses
- Student must raise STEM GPA each semester until a minimum 3.25 STEM GPA is achieved

Services STEM will provide

- Must use Math and Science Tutoring
- Student receives a student education plan and time management plan
- Has priority in all STEM funded courses
- Exposure to new curriculum and teaching methods/improved laboratory facilities
- Will attend at least two STEM program events (i.e. field trips, speakers, etc...)

STEM STUDENT TRACK 2

- Has completed at 2 or more STEM courses
 - GPA requirement 3.25 in STEM courses
- Services STEM will provide
- May use Math and Science tutoring
 - Will enter a mentoring program with STEM faculty and track 1 students
 - Student receives a student educational plan and time management plan
 - Has priority in all STEM funded courses
 - Exposure to new curriculum and teaching methods/improved laboratory facilities
 - Priority for internships, research opportunities, and volunteer positions that STEM has established and develops
 - Can attend all STEM program events (i.e. field trips, speakers, etc.)
 - Eligible for the LAMC Honors Transfer Program

To obtain the STEM program or STEM course application, go to www.lamission.edu/stem

For more information visit the STEM office located in CMS 14.

STEM Director: Mike Fenton, PhD Phone: (818) 364-7888 fentonms@lamission.edu	STEM Counselor: Marina Sangkavichai Phone: (818) 833-3425 sangkam@lamission.edu
---	--

STEM Math Center

818.364.7811

The STEM Math Center provides tutoring for all mathematics courses offered by the college and guidance to complete online assignments and projects. Tutorial services and online resources are provided by friendly, knowledgeable, and patient tutors. Many instructors hold their office hours in the center to assist, advise and interact with students. Textbooks and computers for online homework and resources are available in the lab. All services are free for registered students. No appointment is needed.

Location: East Campus,
Center for Math & Science (CMS), Room 121
Website: www.lamission.edu/mathcenter
Contact: Maria Renteria, STEM Math Center Coord.
Email: rentermd@lamission.edu
Office: 818.833.3321 Lab: 818.364.7811

Workforce Development & Educational Programs

CALIFORNIA WORK OPPORTUNITY & RESPONSIBILITY TO KIDS (CalWORKs)

818.364.7760 | 818.833.3511

www.lamission.edu/calworks

The CalWORKs Program at Los Angeles Mission College assists students who are welfare recipients in making the transition from welfare to long-term self-sufficiency through the following coordinated student services:

- Books and supplies
- On and off-campus work study, which allows students the opportunity to meet the work requirements while attending a community college and obtaining valuable work experience. In many cases, the work study leads to permanent employment.
- Free of charge childcare available at the LAMC Child Development Center and with off-campus licensed childcare providers
- Academic counseling
- Job development and placement services
- Referrals to community resources
- Assistance with completion of all county paperwork
- Advocacy with DPSS and other county agencies
- Life Skills and Problem Solving Workshops
- Supportive atmosphere to enable students to achieve self-sufficiency

Student Information

Program Eligibility

- Must be enrolled in at least one class at Los Angeles Mission College
- Must be a CalWORKs Cash Aid recipient
- Post Employment Students: former welfare recipient (whose last cash aid was received within the last two years) who is currently employed but needs help in upgrading his or her skills, job retention, or job advancement

CALIFORNIA EARLY CHILDHOOD MENTOR PROGRAM

818.364.7714

The purpose of the program is to improve the quality of early childhood programs while creating a career track for experienced teachers and program administrators as they offer training options at their worksites. Mentor teachers are experienced and specially trained teachers of young children whose classroom have been approved as supervision sites for student teacher placements. Stipends are paid to Mentors for their time spent supervising students as well as for participating in professional development activities.

CAREER & TECHNICAL EDUCATION (CTE)

Carl D. Perkins Career and Technical Education Improvement Act of 2006

818.364.7723

The Career and Technical Education program supports continuous program improvement of existing and new programs to meet business/industry standards and promotes the development of programs of study with secondary schools. The goals include increasing student retention and completion of CTE programs, strengthening support services and career awareness for special populations and engaging business and industry in providing internships and work experience.

CAREER TECHNICAL EDUCATION (CTE) TRANSITIONS

818.364.3401

CTE Transitions is a federal initiative developed to address the demand for a highly skilled workforce. The program provides a means for students to begin a program of study in high school, which continues to a community college. These programs combine academic courses needed for success in college and technical courses needed to prepare students for high skilled, high demand careers.

SB1070 CAREER TECHNICAL PATHWAYS PROGRAM

The Pathways program goals are to improve linkages and pathways or course sequences from secondary to postsecondary to work. The components of the program include alignment of CTE high school curriculum to improve regional articulation and regional programs of study, regional alignment of dual enrollment/credit by exam practices, awarding college credit to high school students that have successfully completed articulated course and matriculation services to high school seniors that have completed CTE articulated coursework.

CHILD DEVELOPMENT TRAINING CONSORTIUM

818.364.7714

The Child Development Training Consortium (CDTC) was created to address the critical shortage of qualified early childhood teachers in the state of California. The demand for qualified workers continues to grow. To accomplish this, the Child Development Training Consortium provides financial resources through the Community College Programs who assist students in meeting the educational requirement for any of the Child Development Permits. In addition, the CDTC administers four other programs, including the Child Development

Permit Stipend Program, the Career Incentive Grant Program, and Professional Growth Advisory Project and Administrator Institute.

FAMILY CHILD CARE HOMES EDUCATION NETWORK (FCCHEN)

818.364.7865

The LAMC Family Child Care Homes Education Network consists of 20 licensed family child care homes that offer child care services for the students of Los Angeles Mission College and community. Thirteen of the homes have been accredited. All of the other providers have expressed an interest in completing the accreditation process. Accredited programs adhere to higher standards in all aspects of the program, including parent communication and interactions with children.

FOSTER/KINSHIP CARE EDUCATION (FKCE)

818.364.7600 x7135

LAMC provides more than 350 hours of training to licensed foster parents annually. Classes consist of general parenting information, as well as specific information related to the needs of foster and kinship families. Our training includes classes in both English and Spanish. The Foster and Kinship Care Education program receives funding from the State Chancellor's Office.

GUARDIAN SCHOLARS PROGRAM

818.364.7600 x7135

This program, which was granted through the California College Pathways, the John Burton Foundation and the Stuart foundation, utilizes a strength based approach with foster youth college students at Los Angeles Mission College. Eligible students receive support and resources to ensure college retention and educational success. Through this program, foster youth students meet with coaches and peer mentors on a monthly basis to prepare students for the necessary skills needed for future success.

LA HI-TECH CALIFORNIA CAREER PATHWAYS TRUST

LA HI-TECH Regional Consortium is a strategic partnership which links career pathways across five K-12 systems, three community college districts, and a host of industry and community partners that align with the Information and Communication Technology (ICT) sector. The pathways include Design, Visual and Media Arts, Information Support and Services, and Software Systems and Development. The mission is to provide career pathways for secondary and postsecondary students in an atmosphere of academic rigor and contextualization of numeracy and literacy through collaborative partnerships that lead to gainful employment, and meet the needs and demands of industry employers in the Los Angeles Region.

LINKED LEARNING: A BRIDGE TO COLLEGE AND CAREER SUCCESS

The Career Pathway Trust grant is collaboration between Los Angeles Unified School District – Youth Policy Institute Sylmar Biotech High School Academy and Los Angeles Mission College. The goal of the program is to develop a career pathway which will transform students' high school experiences by bringing together a strong academic component which prepares students for transition to community college, integrating a Career & Technical Component to provide authentic, industry focused real-world learning, offering work-based learning opportunities and providing comprehensive student support services.

LOS ANGELES HEALTHCARE COMPETENCY-TO-CAREER CONSORTIUM (LA H3C)

The Los Angeles Healthcare Competency-to-Career Consortium (LA H3C) is designed to build capacity through the Los Angeles community college system, while deploying innovative learning strategies that will greatly assist career-transitioning individuals. The project will result in a closer connection between community colleges and regional healthcare providers, which will result in many people benefitting by becoming better prepared to enter the workforce. The LA H3C project is designed to build upon prior TAACCCT grant projects in order to deploy a competency-based, stacked and latticed learning model that includes a common foundation for health science-related credential, certificates of achievement and AA/AS degrees.

PARTNERING FOR SAFETY & PERMANENCE - MODEL APPROACH TO PARTNERSHIPS IN PARENTING (PS MAPP)

818.364.7600 x7135

This program is offered through collaboration with the County of Los Angeles and the Community College Foundation. PS-MAPP offers potential foster and adoptive parents a 33-hour training course to help them explore the requirements and challenges that they will accept in the role of foster parent.

SAN FERNANDO VALLEY SCHOLARS NETWORK

818.364.7600 x7135

This program was granted through the California College Pathways, the John Burton Foundation and the Anthony & Jeanne Pritzker Family Foundation. This multi campus network comprised of 3 community colleges (Los Angeles Mission College, Los Angeles Valley College, Pierce college) and California State University, Northridge combines efforts to reduce foster youth student attrition rates and increase successful foster youth student transfer and graduation rates.

TRIO/STUDENT SUPPORT SERVICES (SSS)

818.364.7821 | 818.364.7629

The TRIO/Student Support Services (SSS) Program is a federally funded program designed to identify and provide resources to help students persist through college. SSS provides support services that promote and facilitate students' academic and personal success. To qualify for SSS, students must meet at least one of these requirements:

- Be a first-generation college student (neither parent has a bachelor's degree)
- Meet an income guideline
- Be a student with a disability

Students selected to participate in SSS will qualify for one-on-one academic advising and counseling, individual and group tutoring, career counseling, study skills workshops, trips to cultural sites and colleges, and grant aid through a selective process.

Our Mission Is Your Success

Student Information

Business & Fiscal Services

EAGLES' LANDING STUDENT STORE

(Bookstore) 818.364.7768

Student Store Check Policy

1. We accept checks if you have two forms of identification:
 - (a) A valid California driver's license or California identification card AND
 - (b) A current LAMC student registration receipt or current school ID.
2. Your current address must be imprinted on the check and verified by both your registration receipt and the California driver's license or California identification card.
3. Your check can be written for the amount of purchase only.
4. Your check cannot be a two-party or pre-signed check.
 - 4a. Students who use their parent's check must write their parent's driver's license number and expiration date on the face of the check.
5. Checks can be accepted from registered students only.
6. The student store charges a \$10 fee for each returned check. Los Angeles Mission College will place a hold on registration, transcripts, and all other college transactions until the fee and the amount of the returned check are paid.
7. We accept credit cards - VISA, MasterCard, Discover, and American Express.

Student Store Refund Policy

1. All materials must be returned in the same condition as when purchased. This means that you must not unseal shrink wrap books or class handouts, write in or in any way mark, even with a pencil, a textbook until you are positive you are going to stay in the class and use the book.

Watermarked books are "damaged" books and are non-refundable. The determination of the condition of a book is made by the student store staff. The student store manager is responsible for all decisions, approval or disapproval, concerning refunds.

2. Textbooks and required materials may only be returned between the first and ninth day of the Fall and Spring semesters and within the first week of the summer session and short-term courses.
3. Without exception, any refund, exchange, or replacement must be accompanied by a CURRENT DATED CASH REGISTER RECEIPT issued by the student store.
4. Generally, cash refunds are issued for cash purchases.
 - a. In the event that cash is limited for a particular day, a store credit is issued, which is redeemable on or after the following business day.
5. If you purchase a textbook after the ninth school day, it may only be returned within 24 hours accompanied by its dated cash register sales receipt with prior store manager's authorization, otherwise the sale is final. Any textbook or required material is a final sale after the ninth school day.
6. If a textbook fails to meet the refund policy, it will be treated as a used book. This means that it can be sold by the student during the book buyback period at a maximum of 50 percent of the original purchase price.
7. Supplies may be considered for refund under the following conditions: Items required as materials in certain classes may be refunded during the first nine days of the Fall and Spring semesters and within the first five days of the Summer session. Items returned must be accompanied by their dated cash register receipt,

and they must be in new condition. Athletic supporters, sweat socks, safety goggles, and other "personal items" governed by California health laws are not returnable.

8. Refunds for check purchases are subject to a twenty (20) day waiting period to allow time for bank processing.
9. No refunds will be given on books purchased during midterms and finals.

College Book Buy-Back Policy

During the first week and last week of Spring and Fall semesters ONLY, the student store buys back textbooks that have been pre-adopted by instructors at 50 percent or less of the original price.

STUDENT PARKING REGULATIONS

1. Liability: The Los Angeles Community College District and L.A. Mission College assume no responsibility for damage to any motor vehicle, theft of a vehicle or its contents, or injury to persons operating such vehicles on or off campus.
2. Students should avoid parking in designated LAMC STAFF PARKING LOTS and areas posted NO PARKING ZONES. A valid student parking permit must be displayed to park in the student parking lot.
3. The maximum speed limit is 10 mph on all parking facilities.
4. All persons driving a vehicle on the campus are required to comply with the traffic laws of the state of California and the rules and regulations pursuant to Section 21113A of the California Vehicle Code. Violations may result in a citation being issued.
5. All vehicles must be parked clearly within a designated parking stall.
6. All vehicles shall be parked heading into parking stall.
7. "No Parking" signs must be complied with.

8. Any vehicle parked in a space designated for "Disabled or Handicapped Only" must display a valid handicapped permit or placard issued by the Department of Motor Vehicles.
9. Persons parking illegally on campus will receive a parking citation.
10. Persons parking illegally in the "Disabled or Handicapped Only" parking area will be cited.
11. Parking citations are payable by mail to the address on the citation or online at www.paymycite.com. To appeal a citation, obtain an Administrative Review form from the college Sheriff's Office.
12. Short- term and visitor permits are available at the college Sheriff's Office.
13. The College reserves the right to remove vehicles from the campus for any of the following reasons:
 - a. Abandoned vehicles
 - b. Vehicles with no license plates
 - c. Vehicles parked in such a manner as to constitute a serious hazard
 - d. Vehicles which impede the operation of emergency equipment
 - e. Vehicles which are parked illegally on a recurring basis

NOTE: The registered owner will be responsible for impound costs.

COLLEGE SHERIFF'S DEPARTMENT

818.364.7843

Sheriff's office personnel are responsible for the safety and well being of staff and students and for the security of college property and facilities.

LOST & FOUND

Items left in classrooms or at other campus facilities should be turned in to the Sheriff's Office. Inquiries about lost belongings may be made during regular college hours. The college is not responsible for lost items. Students are advised to put their names on textbooks and other items of value.

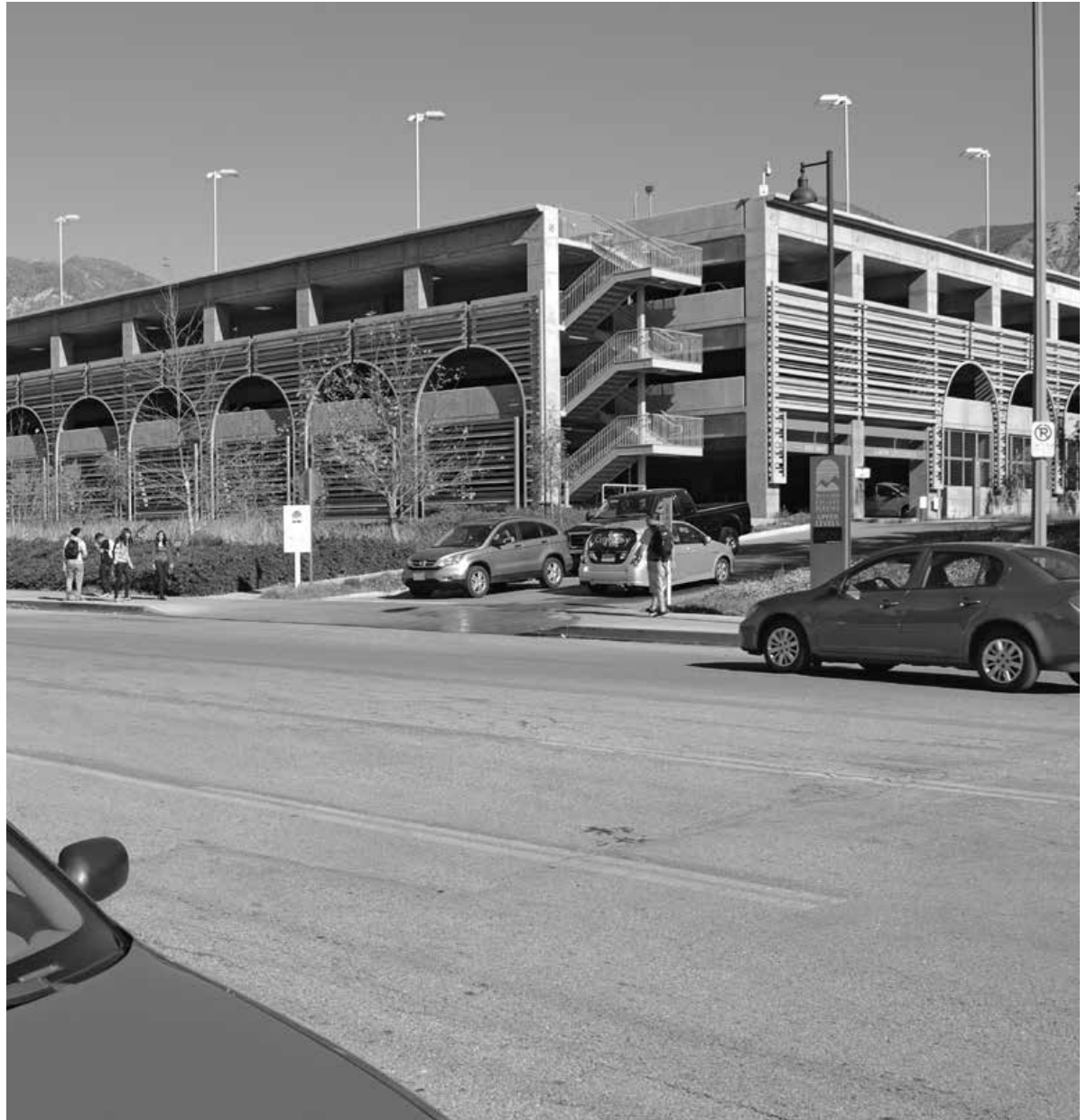

District Information



Academic Standards

ACADEMIC HONORS

Chancellor's Distinguished Honor Award

The Chancellor's Distinguished Honor Award is one of the most significant and praiseworthy honors available to students in the Los Angeles Community College District. This certificate is awarded at the College Commencement exercises. In order to be considered for the award, a candidate must meet the following criteria:

1. Petition for the Associate Degree.
2. Achieve a grade point average of 3.70 or better in all college work attempted at the time of petition and be in good standing.
3. Complete at least 50 percent of all units utilized for the award within the Los Angeles Community College District.
4. Achieve a grade point average of 3.70 and be in good standing in all college work attempted at the end of the Fall semester if graduation requirements will not be completed until the end of the Spring semester.

Please note, Spring candidates for this award will be listed as "Candidates" in the graduation program. After the final grade point evaluation, if the student achieved a 3.70 grade point average, he or she will be awarded the Chancellor's Distinguished Honor Award. Students who possess associate, the equivalent, or advanced degrees are not eligible for this award.

GRADUATION HONORS

Graduation honors and awards are to be based on the student's cumulative grade point average (GPA) for all degree applicable college work attempted. The overall GPA includes all work attempted at LAMC as well as all college-level transfer work attempted at any other regionally accredited institution, regardless of elapsed time.

Summa Cum Laude

Students in attendance at Los Angeles Mission College who have an overall grade point average of 3.90 to 4.00 in all work completed are placed on the Summa Cum Laude list of the College and are honored during graduation.

Magna Cum Laude

Students in attendance at Los Angeles Mission College who have an overall grade point average of 3.70 to 3.89 in all work completed are placed on the Magna Cum Laude list of the College and are honored during graduation.

Cum Laude

Students in attendance at Los Angeles Mission College who have an overall grade point average of 3.30 to 3.69 in all degree applicable college work completed are placed on the Cum Laude list of the College and are honored during graduation.

CRITERIA FOR HONORS CERTIFICATES

Definitions

- A. Full-time student: a student enrolled in twelve (12) or more graded units in the qualifying semester
- B. Part-time student: a student enrolled in six (6) to eleven (11) graded units in the qualifying semester
- C. Qualifying semester: the semester for which the student is considered for the Dean's Honors List
- D. Graded Units: courses in which grades of A, B, C, D, or F were received. Grades of "Pass," "No-Pass," and "Incomplete" will not be counted in meeting the unit requirement for the Dean's or President's Honors List.

Dean's Honors List Requirements

- A. Full-time Dean's Honors List
 - 1. Twelve (12) or more graded units completed in the qualifying semester
 - 2. Grade point average of 3.50 or higher in the qualifying semester
- B. Part-time Dean's Honors List
 - 1. Twelve (12) or more cumulative graded units completed, student is being considered for inclusion on the Dean's Honors List
 - 2. Grade point average of 3.50 or higher in the qualifying semester
- C. Course work used in determination: Only the grades from courses completed at the campus where student is considered for the Dean's Honors List will be used in calculating the grade point average.

President's Honors List

Students who have appeared on the college's full-time or part-time Dean's Honors List for three (3) consecutive semesters will be placed on the President's Honors List.

Transcript Designation

The designation "Dean's Honors List" and "President's Honors List" will be placed on qualifying students' transcripts.

ACADEMIC PROBATION & DISMISSAL

Academic Standards for Probation

The following standards for academic and progress probation shall be applied as required by regulations adopted by the Board of Governors of the California Community Colleges. Probation shall be determined based on student course work dating from Fall, 1981; course work completed prior to Fall of 1981 is excluded from probation calculations.

Probation

A student shall be placed on probation if any one of the following conditions prevail:

- A. *Academic Probation* - The student has attempted a minimum of 12 semester-units of work and has a grade point average less than a "C" (2.00).
- B. *Progress Probation* - The student has enrolled in a total of at least 12 semester-units and the percentage of all units in which a student has enrolled and for which entries of "W" (Withdrawal), "INC" (Incomplete), and "NP" (No-Pass) are recorded reaches or exceeds fifty percent (50%).
- C. *Transfer Student* - The student has met the conditions of (A) or (B) at another college within the Los Angeles Community College District.

Units Attempted to Determine Probation Status

"Units Attempted," for purposes of determining probation status only, means all units of credit in the current community college of attendance for which the student is enrolled.

Removal from Probation

A student shall be removed from probation upon meeting the criteria specified in this section.

Academic Probation

A student on academic probation for a grade point deficiency shall be removed from probation when the student's cumulative grade point average is 2.00 or higher.

Progress Probation

A student who is on progress probation shall be subject to dismissal if the cumulative percentage of units in which the student has been enrolled for which entries of No-Pass (NP), Incomplete (INC), and/or Withdrawal (W) are recorded in at least three (3) consecutive semesters reaches or exceeds fifty percent (50%).

A student who is on progress probation shall not be dismissed after a semester in which the percentage of units in which the student has been enrolled for which entries of "W," "INC," and "NP" are recorded is less than fifty percent (50%). VA students will have to get Academic Progress and Probation clarification from the Campus VA Office.

ACADEMIC STANDARDS FOR DISMISSAL

A student shall be subject to dismissal and subsequently be dismissed under the conditions set forth within this section.

Academic Probation

A student who is on academic probation shall be subject to dismissal if the student has earned a cumulative grade point average of less than 2.00 in all units attempted in each of three (3) consecutive semesters.

A student who is on academic probation and earns a semester grade point average of 2.00 or better shall not be dismissed as long as this minimum semester grade point average is maintained.

Progress Probation

A student who is on progress probation shall be subject to dismissal if the cumulative percentage of units in which the student has been enrolled for

District Information

which entries of No-Pass (NP), Incomplete (INC), and/or Withdrawal (W) are recorded in at least three (3) consecutive semesters reaches or exceeds fifty percent (50%).

A student who is on progress probation shall not be dismissed after a semester in which the percentage of units in which the student has been enrolled for which entries of "W," "INC," and "NP" are recorded is less than fifty percent (50%). VA students will have to get Academic Progress and Probation clarification from the Campus VA Office.

Appeal of Dismissal

A student who is subject to dismissal may appeal to the Vice President of Student Services. Dismissal may be postponed and the student continued on probation if the student shows significant improvement in academic achievement but has not been able to achieve to a level that would meet the requirements for removal from probation.

Dismissal

A student who is subject to dismissal and who has not been continued on probation through the appeal process shall be notified by the College President, or designee, of dismissal, which will become effective the semester following notification. Dismissal from any one college in the District shall disqualify a student from admission to any other college in the District.

Readmission After Dismissal

A student who has been dismissed may request reinstatement after two (2) semesters have elapsed. The student shall submit a written petition requesting readmission to college in compliance with college procedures. Readmission may be granted, denied, or postponed subject to fulfillment of conditions prescribed by the college.

Academic Renewal

Students may petition for an academic renewal action in order to alleviate substandard academic performance under the following conditions:

- A. Students must have achieved a grade point average of 2.5 in their last 15 semester units, or 2.0 in their last 30 semester units completed at any accredited college or university, and
 - B. At least one calendar year must have passed since the course work to be removed was completed.
- See a counselor to complete the academic renewal petition.

Granted, academic renewal shall result in:

- A. Eliminating up to 30 semester units of coursework taken within the Los Angeles Community College District from consideration in the student's cumulative grade point average, and
- B. Annotating the student academic record to note which courses have been removed through academic renewal. Academic renewal actions are irreversible.

Graduation honors and awards are to be based on the student's cumulative grade point average for all college work attempted. <http://www.laccd.edu/Board/Pages/Board-Rules.aspx>

ATTENDANCE

The student is expected to attend every meeting of all classes for which he or she is registered. A student absent from classes for emergency reasons must inform his or her instructor of the reason for the absence.

Students who have preregistered for a class and who do not attend the first meeting of the class may forfeit their right to a place in the class. Students should call the instructor's office to inform the instructor of the circumstances related to the absence. The instructor will then decide if the

reasons provided for the absence are appropriate for allowing the student to remain in class. Mitigating circumstances may be considered by the instructor. Whenever absences "in hours" exceed the number of hours the class meets per week, the student may be excluded from class by the instructor.

It is the student's responsibility to officially drop from any class he/she does not plan to continue to attend. Any drops or exclusions that occur between the end of the 4th week and the end of the 14th week will result in a "W" on the student's record. Drops are not permitted beyond the end of the 14th week. An evaluative grade ("A," "B," "C," "D," "F," "P," or "NP") will be assigned to students who are enrolled past the end of the 14th week. After the last day of the 14th week (or 75 percent of the time the class is scheduled, whichever is less) the student may petition to withdraw from class demonstrating extenuating circumstances. For further details, refer to the "W" section of "Grading Symbols and Definitions."

COURSE REPETITION & ACTIVITY REPETITION

Certain courses in the Catalog may be repeated for additional unit credit. These courses, marked "RPT" in the Course Section of the Catalog, allow the student an expanded educational experience each time the student enrolls in the course. Enrollment in these courses is limited in any similar activity to a maximum of three repeats for a total of four (4) enrollments, regardless of the repeatability of individual courses. The activity limitation also applies to courses which are not repeatable in themselves but for which similar activities exist. For example, there are several similar course titles in art, music, kinesiology and theater, which are considered to be the same activity. A student may

enroll four times in courses which are considered to be the same activity, such as twice in Music 341, Intermediate Piano (RPT 3). Any combination may be used as long as the limit of four (4) enrollments in one activity is not exceeded.

Excess enrollment will result in administrative drop. Consult a counselor for the latest restricted activity enrollment list.

NOTE: Whenever the student's record is reviewed for the purpose of determining her/his unit credits, all of the student's record is reviewed.

Course Repetition to Improve Substandard Grades

Students may petition for approval to repeat substandard grades (less than "C", 2.00) awarded. Students may repeat the same course only once for this purpose.

Upon completion of a repeated course, the highest grade earned will be computed in the cumulative grade point average, and the student's academic record will be so annotated. No specific course or categories of courses shall be exempt from course repetition.

This policy is adopted for use in the Los Angeles Community College District only. Other institutions may differ, and students planning to transfer to another college should contact that institution regarding its policy.

Course Repetition: Special Circumstances

Repetition of courses for which substandard work has not been recorded shall be permitted only upon advance petition of the student and with written permission of the College President or designee based on a finding that circumstances exist which justify such repetition. In such repetition under special circumstances, the student's permanent academic record shall be annotated in such a manner that all work remains legible. Grades awarded for repetition under special circumstances shall not be counted in calculating a student's grade point average.

CONCURRENT ENROLLMENT

Concurrent enrollment in more than one section of the same course during a semester is not permitted, with the exception of certain kinesiology classes on a limited basis.

Concurrent enrollment in courses which are cross-referenced to each other is not permitted (i.e., courses designated "same as" in the District Directory of Educational Programs and Courses). Violation of this regulation will result in exclusion from class and denial of course credit in both courses.

Enrolling in classes scheduled or conducted during overlapping times is not permitted. In addition to exclusion from both classes and denial of credits, violators will be subject to disciplinary action (See Standards of Student Conduct).

K to Eighth Grade Students (Young Students)

Any Concurrent Enrollment student application for a student who has not completed eighth grade must be reviewed by the K to 8 committee. These students must apply to the school and take the assessment test, if the student scores at English 101 and Math 125 then they could submit a letter of recommendation and current transcript. The application is reviewed by committee every semester until the student completes eighth grade.

AWARDING CREDIT

Los Angeles Mission College recognizes work completed at other accredited colleges and experiences outside of the traditional classroom setting.

CREDIT FOR COURSES COMPLETED AT NON-ACCREDITED INSTITUTIONS

Students transferring from non-accredited institutions may, after successful completion of 30 units with a "C" or better average, apply for up to fifteen (15) units of credit in courses which parallel the offerings of the college. The following exceptions may be made to this regulation:

1. Credit for Graduates of Diploma Schools of Nursing
The following amount of credit is authorized for

graduates of Diploma Schools of Nursing who enter the Los Angeles Community Colleges:

- a. Thirty (30) semester units of credit will be given to graduates of Diploma Schools of Nursing under the following conditions:
 - (1) The student presents a valid, current California certificate as a licensed registered nurse to the designated administrative officer;
 - (2) The student has completed at least 12 units of credit at the college to which application is made.
 - b. The work of graduates of Diploma Schools of Nursing outside California will be recognized if the student has a valid, current California license. Credit will be given even though the license was obtained on the basis of reciprocity with another state rather than by examination.
 - c. Candidates for the Associate in Arts or Associate in Science Degree are exempt from Health Education as a General Education Requirement. No other general education requirements will be waived.
 - d. Additional courses in nursing may be taken for credit only upon approval of the Nursing Department.
 - e. The transcript is not to reflect the major field nor should the diploma, where given, indicate Nursing as a major.
2. Credit for Military Service Training
Students who are currently serving in or have served in the military service may request an evaluation of credit earned through military service training schools and/or military occupational specialties. Credit units may be granted up to the number recommended by the American Council on Education (ACE). Former Military Personnel currently NOT on Active Duty: Active Duty documentation (DD214) must indicate student's length of services, which must include 181 days of active duty.
 3. Credit for Law Enforcement Academy Training
Credit for basic recruit academy training

District Information

instructional programs in Administration of Justice or other criminal justice occupations shall be granted as follows:

- a. Credit will be given for training from institutions which meet the standards of training of the California Peace Officers Standards and Training Commission. This only applies to training received at public law enforcement academies; training provided by private agencies does not apply.
- b. Course credit may be granted, if the faculty in the discipline determine that the content of the academy training is equivalent to courses offered in the discipline.
- c. One (1) unit of credit may be granted for each 50 hours of training, not to exceed eighteen (18) semester units or their equivalent.
- d. Twelve (12) units must be completed in residence at L.A. Mission College.
- e. Students granted block credit for basic academy training may receive 1 unit of Kinesiology (activity) to meet the AA/AS degree, general education requirements (area E2), at the time of graduation from LAMC.

CREDIT FOR COURSES COMPLETED AT FOREIGN INSTITUTIONS

Students who have completed college-level courses at schools outside the United States may petition for an unlimited number of lower division units of credit toward an associate degree or certificate after completion of 12 units at L.A. Mission College with a "C" or better GPA. The student may petition under the following conditions:

1. Students must submit a detailed evaluation from an approved evaluation service. Students are responsible for the cost of this service.
2. The foreign university or college must have been approved by that country's Ministry of Education

at the time the student attended.

3. No courses may be used to satisfy the associate degree's reading and written expression or oral communication requirement unless the course was taken in a country where English is the native language.
4. No course may be used to satisfy the associate degree's American Institutions requirement.
5. In cases where equivalent course credit is not granted, elective credit may be awarded.

PREVIOUSLY EARNED COLLEGE UNITS

College credits earned at regionally accredited institutions of higher education will be recognized. Acknowledgement of receipt of transcripts will be posted to the student's permanent record. Students must arrange for each college previously attended to mail official, sealed transcripts to the Office of Admission and Records, directly from that institution.

CREDIT BY EXAMINATION

Some courses in the college catalog are eligible for credit by examination.

1. Method of obtaining credit by examination
 - a. Credit by satisfactory completion of an examination administered by the college in lieu of completion of a course listed in the college catalog and approved for Credit by Exam.
 - b. Achievement of a score that qualifies for credit on an examination administered by other agencies approved by the college
2. Determination of eligibility to take the examinations
 - a. The student must be currently registered in the college, in good standing and with a minimum grade point average of 2.00 in any work attempted at the College
 - b. The student must have completed 12 units at the College, unless the student is petitioning

for a Career Technical Education course with an approved high school articulation agreement. The student has not completed a course or in the process of taking a course which is more advanced than the course for which credit is requested.

3. Maximum credit and limitations
 - a. The maximum number of credits allowable for credit by examination for the associate degree shall be fifteen (15) units. Credit by examination transferred from other institutions is counted toward this maximum.
 - b. Credits acquired by examination are not applicable to meeting such unit load requirements as Selective Service deferment, Veteran's, or social security benefits
 - c. Units for which credit is given pursuant to the provision of this section shall not be counted in determining the 12 units of credit in residence requirement.
 - d. A student who does not pass the exam for a course may not repeat the exam.

4. Recording of Credit
 - a. The student's academic record shall be clearly annotated to reflect that credit was earned by examination. Grading shall be according to the regular grading method of the course, except that students shall be offered a "pass-no pass" option if that option is ordinarily available for the course. The number of units of credit recorded for any course may not exceed those listed in the college catalog.

5. Filing a Petition
Students must work with the discipline faculty to verify eligibility and determine the date and time of the examination. Paperwork must be processed by a full-time faculty member in the discipline and can only be completed for a course approved for credit by exam, by the department.

ADVANCED PLACEMENT INFORMATION

Advanced Placement (AP) Exam Credit

Awarding of advanced placement exam credit is applicable based on academic goal. Every college and university has its own policy for awarding credit for passed AP exams. Credit acquired by AP examinations is not applicable toward meeting unit-load requirements for athletic eligibility, social security benefits, or Veterans Administration benefits. *PLEASE NOTE: Transfer students must check with the college or university they plan to transfer to for the institution's Advanced Placement policy.*

Students who take an Advanced Placement (AP) exam, an International Baccalaureate (IB) exam or College-Level Examination Program (CLEP) exam in the same topic area will receive credit for only one exam. (For example, if a student takes both the CLEP exam in Biology and the AP exam in Biology, they will only be awarded credit for one exam because the topics are duplicative). The college should award credit for the exam that most benefits the student.

Official AP score reports must be mailed directly to the Admissions Office from the College Entrance Examination Board (www.collegeboard.com).

1. Passed Advanced Placement exams must have a score of 3 or higher, administered by the College Examination Board. Some institutions require higher scores for course credit, therefore students should check with the Transfer Center, their counselor and/or the institution to which they plan to transfer.
2. Course applicability is for L.A. Mission College Associate Degree requirements. To be eligible for course applicability for Advanced Placement exams, the student must have completed a minimum of 12 units in residence. Request must be submitted in writing to the office of Admissions and Records. It is recommended that the student meet with a counselor.

3. Students interested in transfer to a CSU or UC campus and are following the CSU GE Breadth or IGETC may count passed AP exams toward fulfillment of subject areas on each of these plans as determined by the policies of the CSU and UC systems. Students must check with the individual campus to determine if any specific course credit will be awarded. There is no relation between the credit awarded on these general education patterns and the course credit that each CSU and UC campus may award; actual AP transfer credit awarded for these and other AP exams for admission is determined by the CSU and UC. Also, there is no relation between the credit awarded on these general education patterns and the course credit awarded by L.A. Mission College (see charts, pages 50-51). *NOTE: It is rare that a college or university allow a passed AP exam to fulfill a course requirement that is necessary to meet major preparation.* Private institutions also have their own AP policies that must be researched. It is highly recommended that students consult with a Counselor for more information. CSU GE AP Policy details may be found on the CSU Chancellor's website: www.calstate.edu/app/general-ed-transfer.shtml UC AP Policy details may be found on the UC website: www.universityofcalifornia.edu/admissions/counselors/ap-credits/index.html
4. Applicability as listed, will not grant course credit for L.A. Mission College Associate Degree major requirements, certificate requirements or units awarded. All course credit applicable to L.A. Mission College major requirements, certificate requirements or unit credit are listed separately. Please consult with a counselor for more information.

NOTE: L.A. Mission College course credit is not related to the AP policy of the CSU GE Breadth or IGETC patterns.

Campus Credit for AP Exams

All course credit applicable to L.A. Mission College major requirements, certificate requirements or unit credit ONLY, are listed separately in the following table. *PLEASE NOTE: Applicability for LAMC areas of general education are listed in the table below. All advanced placement exams used to fulfill LAMC requirements, as listed below, MUST have a passing score of 3, 4 or 5. All units listed as semester units only. Please consult with a counselor for more information.*

PLEASE NOTE: L.A. Mission College course credit is ONLY applicable to meet requirements for LAMC Associate Degree majors or Certificate requirements.

LAMC course credit is not related to the AP policy of the CSU or UC system or the granting of applicability for the CSU GE Breadth, IGETC or Certification. For more information on those policies or applicability for CSU GE, IGETC and/or Certification, please consult the grid entitled "LACCD Credit for AP Exams."

AP Subject area	LAMC Course Credit
Art: History Studio Drawing	Art 101, 102 Art 201, 202
Biology	Biology 3
Chemistry	Chem 65
English Language & Composition	English 101
Economics	Econ 1, 2
French Language	French 1
Government & Politics: US	PolSci 1
Government & Politics: Comparative	PolSci 2
History: U.S.	Hist 11 and 12
History: World	Hist 86 + 3 elective units
Math: Calculus AB Calculus BC	Math 265 Math 265 (+5 add'l elective units if both exams taken)
Music Theory	Music 111
Physics B	Physics 6, 7
Psychology	Psych 1
Spanish Language Spanish Literature	Spanish 3 Spanish 3 (+6 add'l elective units if both exams taken)

District Information

LACCD Credit for Advanced Placement (AP) Exams

All AP exams used to fulfill requirements as listed below MUST have a passing score of 3, 4 or 5. All units listed as semester units only. Please refer to the

chart for specific course applicability. Please consult with a counselor and/or the Transfer Center for more information. For CSU GE credit, please remember to verify date exam was taken (all gray boxes indicate effective removal dates).

AP Subject Area	AP Score	Total Semester Units Awarded Toward Associate Degree	Semester Units Applied Toward Associate Degree GE Requirements	Associate Degree GE Area Fulfilled Board Rule: Chapter VI: 6201.14	Graduation Competency Requirement Fulfilled Board Rule: Chapter VI: 6201.12	Title 5 American Institutions Requirement Fulfilled Board Rule: Chapter VI: 6201.14	IGETC Applicability Source: IGETC Standards v 1.5	CSU GE Breadth Applicability Source: CSU Coded Memo AA-2014-21
Art Studio Drawing	3, 4, 5	3	3	Section C: Humanities			NA	NA
Art Studio 2D Design	3, 4, 5	3	3	Section C: Humanities			NA	NA
Art Studio 3D Design	3, 4, 5	3	3	Section C: Humanities			NA	NA
Art History	3, 4, 5	6	3	Section C: Humanities			3A or 3B 3 semester units/4 quarter units	C1 or C2 3 semester units
Biology	3, 4, 5	6	3	Section A: Natural Science			5B and 5C 4 semester units/5 quarter units	B2 and B3 4 semester units
Chemistry	3, 4, 5	6	3	Section A: Natural Science			5A and 5C 4 semester units/5 quarter units	B1 and B3 4 semester units
Chinese Language & Culture	3, 4, 5	6	3	Section C: Humanities			3B and 6A 3 semester units/4 quarter units	C2 3 semester units
Computer Science Exam A	3, 4, 5	3	3	Section D: Language & Rationality: Area 2.Communication and Analytical Thinking			NA	NA
Computer Science Exam AB	3, 4, 5	6	3	Section D: Language & Rationality: Area 2.Communication and Analytical Thinking			NA	NA
Economics – Macroeconomics	3, 4, 5	3	3	Section B2: Social and Behavioral Sciences			4B 3 semester units/4 quarter units	D2 3 semester units
Economics – Microeconomics	3, 4, 5	3	3	Section B2: Social and Behavioral Sciences			4B 3 semester units/4 quarter units	D2 3 semester units
English Language & Composition	3, 4, 5	3	6	Section D: Language & Rationality: Area 1. English Composition	Reading and Written Expression Competency Satisfied		1A 3 semester units/4 quarter units	A2 3 semester units
English Literature & Composition	3, 4, 5	6	6	Section D: Language & Rationality: Area 1. English Composition	Reading and Written Expression Competency Satisfied		1A or 3B 3 semester units/4 quarter units	A2 and C2 6 semester units
Environmental Science	3, 4, 5	4	3	Section A: Natural Science			5A and 5C 3 semester units/4 quarter units	B1 and B3 4 semester units
French Language & Culture	3, 4, 5	6	3	Section C: Humanities			3B and 6A 3 semester units/4 quarter units	C2 3 semester units
French Literature	3, 4, 5	6	3	Section C: Humanities			3B and 6A 3 semester units/4 quarter units	C2 3 semester units (removal fall 09)
German Language & Culture	3, 4, 5	6	3	Section C: Humanities			3B and 6A 3 semester units/4 quarter units	C2 3 semester units
Government & Politics: U.S.	3, 4, 5	3	3	Section B1: American Institutions		American Institutions Satisfied	4H and US-2 3 semester units/4 quarter units	D8+US-2 3 semester units
Government & Politics: Comparative	3, 4, 5	3	3	Section B2: Social and Behavioral Sciences			4H 3 semester units/4 quarter units	D8 3 semester units

LACCD Credit for Advanced Placement (AP) Exams - continued

AP Subject Area	AP Score	Total Semester Units Awarded Toward Associate Degree	Semester Units Applied Toward Associate Degree GE Requirements	Associate Degree GE Area Fulfilled Board Rule: Chapter VI: 6201.14	Graduation Competency Requirement Fulfilled Board Rule: Chapter VI: 6201.12	Title 5 American Institutions Requirement Fulfilled Board Rule: Chapter VI: 6201.14	IGETC Applicability Source: IGETC Standards v 1.5	CSU GE Breadth Applicability Source: CSU Coded Memo AA-2014-21
History: European	3, 4, 5	6	6	Section B2: Social and Behavioral Sciences AND Section C: Humanities			3B or 4F 3 semester units/4 quarter units	C2 or D6 3 semester units
History: U.S.	3, 4, 5	6	6	Section B1: American Institutions		American Institutions Satisfied	3B or 4F and US-1 3 semester units/4 quarter units	C2 or D6 + US-1 3 semester units
History: World	3, 4, 5	6	6	Section B2: Social and Behavioral Sciences			3B or 4F 3 semester units/4 quarter units	C2 or D6 3 semester units
Human Geography	3, 4, 5	3	3	Section B2: Social and Behavioral Sciences			4 3 semester units/4 quarter units	D5 3 semester units
Italian Language & Culture	3, 4, 5	6	3	Section C: Humanities			3B and 6A 3 semester units/4 quarter units	C2 3 semester units
Japanese Language & Culture	3, 4, 5	6	3	Section C: Humanities			3B and 6A 3 semester units/4 quarter units	C2 3 semester units
Latin Literature	3, 4, 5	6	3	Section C: Humanities			3B and 6A 3 semester units/4 quarter units	C2 3 semester units (removal fall 09)
Latin: Vergil	3, 4, 5	3	3	Section C: Humanities			3B and 6A 3 semester units/4 quarter units	C2 3 semester units (removal fall 12)
Mathematics – Calculus AB	3, 4, 5	3	3	Section D: Language & Rationality: Area 2. Communication and Analytical Thinking	Mathematics Competency Satisfied		2A 3 semester units/4 quarter units	B4 3 semester units
Mathematics – Calculus BC	3, 4, 5	6	6	Section D: Language & Rationality: Area 2. Communication and Analytical Thinking	Mathematics Competency Satisfied		2A 3 semester units/4 quarter units	B4 3 semester units
Mathematics – Calculus BC/AB Subscore	3, 4, 5	3	3	Section D: Language & Rationality: Area 2. Communication and Analytical Thinking	Mathematics Competency Satisfied		2A 3 semester units/4 quarter units	B4 3 semester units
Music Theory	3, 4, 5	6	3	Section C: Humanities			NA	C1 3 semester units (removal fall 09)
Physics 1	3, 4, 5	3	4	Section A: Natural Science			Under review by UC	B1 and B3 4 semester units
Physics 2	3, 4, 5	3	4	Section A: Natural Science			Under review by UC	B1 and B3 4 semester units
Physics B	3, 4, 5	6	3	Section A: Natural Science			5A and 5C 4 semester units/5 quarter units	B1 and B3 4 semester units (removal fall 13)
Physics C Mechanics	3, 4, 5	4	3	Section A: Natural Science			5A and 5C 3 semester units/4 quarter units	B1 and B3 4 semester units
Physics C Electricity & Magnetism	3, 4, 5	4	3	Section A: Natural Science			5A and 5C 3 semester units/4 quarter units	B1 and B3 4 semester units
Psychology	3, 4, 5	3	3	Section B2: Social and Behavioral Sciences			4 3 semester units/4 quarter units	D9 3 semester units
Spanish Language & Culture	3, 4, 5	6	3	Section C: Humanities			3B and 6A 3 semester units/4 quarter units	C2 3 semester units
Spanish Literature & Culture	3, 4, 5	6	3	Section C: Humanities			3B and 6A 3 semester units/4 quarter units	C2 3 semester units
Statistics	3, 4, 5	3	3	Section D: Language & Rationality: Area 2. Communication and Analytical Thinking	Mathematics Competency Satisfied		2A 3 semester units/4 quarter units	B4 3 semester units

District Information

CLEP INFORMATION (COLLEGE-LEVEL EXAMINATION PROGRAM)

CLEP Credit

Awarding of CLEP exam credit is applicable based on academic goal. Every college and university has its own policy for awarding credit for passed CLEP exams. CLEP exams shall be used to meet general education requirements and graduation competency for the Associate Degrees (BR Chapter VI, Article II). *PLEASE NOTE: For more information, students should check with the Transfer Center, a counselor and/or the college or university they plan to transfer to for the institution's CLEP policy.*

Students who take an Advanced Placement (AP) exam, an International Baccalaureate (IB) exam or College-Level Examination Program (CLEP) exam in the same topic area will receive credit for only one exam (For example, if a student takes both the CLEP exam in Biology and the AP exam in Biology, they will only be awarded credit for one exam because the topics are duplicative). The college should award credit for the exam that most benefits the student.

Official CLEP score reports must be mailed directly to the Admissions Office from the College Entrance Examination Board (www.collegeboard.com).

1. Most CLEP exams must have a passing score of 50, except for Foreign Language level 2 which requires a higher score.
2. Course applicability is for LAMC Associate Degree requirements. To be eligible for course applicability for CLEP exams, the student must be enrolled at LAMC during the semester in which credit is to be granted and have completed a minimum of 12 units in residence. It is recommended that the student meet with a counselor prior to filing a petition with the Admissions and Records office.
3. Students interested in transfer to a CSU or UC campus and are following the CSU GE Breadth or IGETC may count passed CLEP exams toward fulfillment of subject areas on each of these plans as determined by the policies of the CSU and UC systems. Students must check with the individual campus to determine if any specific course credit will be awarded. There is no relation between the credit awarded on these general education patterns and the course credit that

each CSU and UC campus may award; actual CLEP transfer credit awarded for these and other CLEP exams for admission is determined by the CSU and UC. Private institutions also have their own AP policies that must be researched. It is highly recommended that students consult with a Counselor for more information.

CSU GE CLEP Policy details may be found on the CSU Chancellor's website: www.calstate.edu/app/general-ed-transfer.shtml

CLEP exams cannot be used on IGETC.

4. Applicability as listed, will not grant course credit for L.A. Mission College Associate Degree major requirements, certificate requirements or units awarded; course equivalency does not award unit credit. For the purpose of granting unit credit to meet general education and graduation competency requirements, the guidelines set by the American Council on Education (ACE) should be followed:
 - 3 semester hours are recommended in the case of a half-year course.
 - 6 semester hours for most full-year courses.
 - 12 semester hours for Level 2 Foreign Language exams equivalent to four semesters of college level foreign language course work.

LACCD Credit for College-Level Examination Program (CLEP) Exams

All CLEP exams used to fulfill requirements as listed below MUST have a passing score of 50 unless otherwise noted. The scores and credit hours that appear in this table (and on next page) are the credit-granting scores and semester hours recommended by the

American Council on Education (ACE). The scores listed are equivalent to a grade of "C" in the corresponding course. All units listed as semester units only.

Please consult with a counselor and/or the Transfer Center for more information.

CLEP Exam		Total Units Towards Associate Degree	Associate Degree GE Area Fulfilled Board Rule: Chapter VI: 6201.14	CSU GE Breadth min units (CSU Coded Memo AA-2015-02)	CSU GE Applicability (CSU Coded Memo AA-2015-02)√
Business	Financial Accounting	3	N/A	3	N/A
	Information Systems and Computer Applications	3	3 units, Section D2: Lang & Rationality - Communication and Analytical Thinking	3	N/A
	Introductory Business Law	3	N/A	3	N/A
	Principles of Management	3	N/A	3	N/A
	Principles of Marketing	3	N/A	3	N/A
Composition & Literature	American Literature	6	3 units, Section C: Humanities	3	3 units, Area: C2
	Analytical and Interpreting Literature	6	3 units, Section C: Humanities	3	3 units, Area: C2
	College Composition (replaces English Composition w/essay, effective 07/01/10)	6	6 units, Section D1: Lang & Rationality - English Comp	0	N/A
	College Composition Modular (replaces English Composition and Freshman College Composition Exams, effective 07/01/10)	6	6 units, Section D1: Lang & Rationality - English Comp	0	N/A
	English Literature	6	3 units, Section C: Humanities	3	3 units, Area: C2
	Humanities	6	3 units, Section C: Humanities	3	3 units, Area: C2
Foreign Languages	French Language, Level 1	6	3 units, Section C: Humanities	6*	N/A
	French Language, Level 2 ^	12	3 units, Section C: Humanities	12*	3 units, Area: C2
	German Language, Level 1	6	3 units, Section C: Humanities	6*	N/A
	German Language, Level 2 ^	12	3 units, Section C: Humanities	12*	3 units, Area: C2
	Spanish Language, Level 1	6	3 units, Section C: Humanities	6*	N/A
	Spanish Language, Level 2 ^	12	3 units, Section C: Humanities	12*	3 units, Area: C2

Level 1 - equivalent to the first 2 semesters (6 semester hours) of college-level foreign language course work

Level 2 - equivalent to the first 4 semesters (12 semester hours) of college-level foreign language course work

District Information

LACCD Credit for College-Level Examination Program (CLEP) Exams - continued

CLEP Exam		Total Units Toward Associate Degree	Associate Degree GE Area Fulfilled Board Rule: Chapter VI: 6201.14	CSU GE Breadth min units (CSU Coded Memo AA-2015-02)	CSU GE Breadth Applicability (CSU Coded Memo AA-2015-02) [∇]
Science and Mathematics	Biology	6	3 units, Section A: Natural Science	3	3 units, Area: B2
	‡ Calculus	3	3 units, Section D2: Lang & Rationality - Communication and Analytical Thinking	3	3 units, Area: B4
	Chemistry	6	3 units, Section A: Natural Science	3	3 units, Area: B1
	‡ College Algebra	3	3 units, Section D2: Lang & Rationality - Communication and Analytical Thinking	3	3 units, Area: B4
	‡ College Mathematics	6	3 units, Section D2: Lang & Rationality - Communication and Analytical Thinking	0	N/A
	‡ Precalculus	3	3 units, Section D2: Lang & Rationality - Communication and Analytical Thinking	3	3 units, Area: B4
	Natural Sciences	6	3 units, Section A: Natural Science	3	3 units, Area: B1 or B2
	College Algebra – Trigonometry			3	3 units, Area: B4
	Trigonometry			3	3 units, Area: B4
History and Social Sciences	⁺ American Government	3	3 units, Section B1: American Institutions	3	3 units, Area D8
	⁺ History of the United States I: Early Colonization to 1877	3	3 units, Section B1: American Institutions	3	3 units, Area: D6 +US-1
	⁺ History of the United States II: 1865 to present	3	3 units, Section B1: American Institutions	3	3 units, Area: D6 +US-1
	Human Growth and Development	3	3 units, Section B2: Social & Behavioral Sciences	3	3 units, Area: E
	Introduction to Educational Psychology	3	3 units, Section B2: Social & Behavioral Sciences	3	NA
	Introductory Psychology	3	3 units, Section B2: Social & Behavioral Sciences	3	3 units, Area: D9
	Introductory Sociology	3	3 units, Section B2: Social & Behavioral Sciences	3	3 units, Area: D0
	Principles of Macroeconomics	3	3 units, Section B2: Social & Behavioral Sciences	3	3 units, Area: D2
	Principles of Microeconomics	3	3 units, Section B2: Social & Behavioral Sciences	3	3 units, Area: D2
	Social Science and History	3	3 units, Section B2: Social & Behavioral Sciences	0	NA
	Western Civilization I: Ancient Near East	3	3 units, Section B2: Social & Behavioral Sciences	3	3 units, Area: C2 or D6
Western Civilization II: 1648 to Present	3	3 units, Section B2: Social & Behavioral Sciences	3	3 units, Area: D6	

¹The scores and credit hours that appear in this table are the credit-granting scores and semester hours recommended by the American Council on Education (ACE).

[∇]Areas of GE Breadth (A1-E) are defined in EO 1033. Areas of American Institutions (US-1 through US-3) are set forth in Sections IA and IB of EO 405, and at ASSIST.org.

[^]Level 2 Languages require the following minimum, passing score: French Level 2 = 59, German Level 2 = 60 (this is the recommended score for exams administered after June 30, 2008), Spanish Level 2 = 63. [Sources: <http://www.collegeboard.com/student/testing/clep/about.htm>]

*CSU Policy: if a student passes more than one CLEP exam in the same language other than English, only one exam may be applied to the baccalaureate.

‡Mathematics Competency Satisfied [Fulfillment of Graduation Competency, BR Chap VI: 6201.12]

⁺American Institutions Satisfied [Fulfillment of Title 5: American Institutions, BR Chap VI: 6201.14]

INTERNATIONAL BACCALAUREATE (IB)

The International Baccalaureate (IB) assesses student work as a direct evidence of achievement against the stated goals of the IB Diploma Program courses. Students must have completed a high school IB Diploma Program to be eligible to take the IB exams. For more information go to:

<http://www.ibo.org/diploma>

<http://admission.universityofcalifornia.edu/counselors/exam-credit/ib-credits/index.html>

<http://www.calstate.edu/app/general-ed-transfer.shtml>

CREDIT FOR PREREQUISITES

Students may not concurrently enroll in and receive credit for an advanced course and its prerequisite(s). Students may not enroll in and receive credit for the prerequisite(s) to an advanced course if they have previously completed the advanced course. Violation of this regulation will result in exclusion from class and denial of course credit.

PASS/NO-PASS OPTION

The College President may designate courses in the College Catalog wherein all students are evaluated on a "Pass/No-Pass" basis or wherein each student may elect on registration or no later than the end of the first 30 percent of the term whether the basis of evaluation is to be "Pass/No-Pass" or a letter grade. These courses will be noted in the College Catalog as being eligible for the Pass/No-Pass option.

1. Usage for Single Performance Standard

The Pass/No-Pass grading system shall be used in any course in which there is a single satisfactory standard of performance for which unit credit is assigned. A grade of Credit (CR) shall be assigned for meeting that standard, and a grade of No-Credit (NC) shall be assigned for failure to do so.

2. Acceptance of Credits

All units earned on a Pass/No-Pass basis in accredited California institutions of higher education or equivalent out-of-state institutions shall be counted in satisfaction of community college curriculum requirements.

3. Recording of Grade

A student who is approved to be evaluated on the Pass/No-Pass basis shall receive both course credit and unit credit upon satisfactory completion of the course. Satisfactory completion for credit is equivalent to the grade of "C" or better. A student who does not perform satisfactorily will be assigned a No-Credit (NC) grade.

4. Grade Point Calculation

Units earned on a Pass/No-Pass basis shall not be used to calculate grade point averages. However, units attempted for which No-Credit (NC) is recorded shall be considered in probationary and dismissal procedures.

5. Standards of Evaluation

The student who is enrolled in a course on a Pass/No-Pass basis will be held responsible for all assignments and examinations required in the course and must meet the standards of evaluation, which are identical for all students.

6. Conversion to Letter Grade

A student who has received Credit for a course taken on a Pass/No-Pass basis may not convert this Credit to a letter grade.

7. Course Repetition

A student who has received a grade of No-Credit (NC) may repeat the course by meeting the requirements set forth by the District Course Repetition to Improve Substandard Grades Policy.

Campus Procedure on Pass/No-Pass Option

A maximum of fifteen (15) units on a Pass/No-Pass basis may be applied toward the Associate Degree. Courses taken for Pass/No-Pass may be a requirement of the student's major.

Unit and course credit will be granted on a Pass/No-Pass basis under the following conditions:

1. A student wishing to take a course on a Pass/No-Pass basis will go to the Admissions and Records Office before the end of the 6th week of a semester (the 2nd week of a Summer session or the 3rd week of a nine-week short-term session) and record her/his choice by completing the proper form.
2. A student who elects to be evaluated on a Pass/No-Pass basis does not have the option of reversing her/his decision at a later date.
3. Veteran students will not receive VA payment for No-Credit grades.

The general practice at most four-year colleges is to not accept Pass/No-Pass grades for courses required in the major or preparation for the major. The student at L.A. Mission College has the option of taking the majority of the courses available on a Pass/No-Pass basis or for a letter grade. English 101 is NOT available on a Credit/No-Credit basis.

The following is a list of courses which are available only as Pass/No-Pass:

- Developmental Communications (all courses)
- English 21
- English as a Second Language (all courses)

FINAL EXAMINATIONS

Final examinations are held in all subjects according to the published final examination schedule. No student will be excused from the final examinations. Should any circumstance develop requiring a special examination at a time other than the scheduled time, special authorization must be secured from the Office of the Vice President of Academic Affairs.

District Information

GRADING SYMBOLS & DEFINITIONS

Only the symbols in the grading scale given in this section shall be used to grade all courses offered in fulfillment of the requirements for an associate or baccalaureate degree, a certificate, diploma, or license.

Grades shall be averaged on the basis of the grade point equivalencies to determine a student's grade point average, using the following evaluative symbols:

Symbol	Definition	Grade Point
A	Excellent	4
B	Good	3
C	Satisfactory	2
D	Passing, less than satisfactory	1
F	Failing	0
CR	Credit (at least equal to a "C" grade or better – units awarded are not counted in GPA)	
NC	No-Credit (equal to a "D" or "F" grade – units are not counted in GPA) CR and NC grades may be given only in courses authorized by the District Credit/No-Credit Option and Credit by Examination Policies	

The following non-evaluative symbols may be entered on a student's record:

SYMBOL: CR/NCR

DEFINITION: Credit or Pass (at least satisfactory-units not counted on GPA)/No-Credit or No-Pass (less than satisfactory – units not counted in GPA)

SYMBOL: INC

DEFINITION: Incomplete

Incomplete academic work for unforeseeable, emergency, and justifiable reasons at the end of the term may result in an "INC" symbol being entered in the student's record. The condition for removal

of the "INC" shall be stated by the instructor in a written record.

This record shall contain the condition for removal of the "INC" and the grade assigned in lieu of its removal. This record shall be given to the student with a copy on file in the college Admissions and Records Office until the "INC" is made up or the time limit has passed. A final grade shall be assigned when the work stipulated has been completed and evaluated or when the time limit for the work has passed.

The "INC" symbol shall not be used in calculating units attempted nor for grade points. THE "INC" MAY BE MADE UP NO LATER THAN ONE YEAR FOLLOWING THE END OF THE TERM IN WHICH IT WAS ASSIGNED. The student may petition for a time extension due to unusual circumstances.

NOTE: Courses in which the student has received an Incomplete ("INC") may not be repeated unless the "INC" is removed and has been replaced by a grade of "D" or "F." This does not apply to courses which are repeatable for additional credit.

SYMBOL: IP

DEFINITION: In Progress

The "IP" symbol shall be used only in those courses that extend beyond the normal end of an academic term. "IP" indicates that work is "in progress," and that assignment of a substantive grade must await its completion. The "IP" symbol shall remain on the student's permanent record in order to satisfy enrollment documentation. The appropriate evaluative grade and unit credit shall be assigned and appear on the student's record for the term in which the required work from the course is completed. The "IP" shall not be used in calculating grade point averages. If a student enrolled in an "open-entry, open-exit" course is assigned "IP" at the end of an attendance period and does not complete

the course during the subsequent attendance period, the appropriate faculty will assign an evaluative symbol (grade) as specified above to be recorded on the student's permanent record for the course.

SYMBOL: P/NP

DEFINITION: Pass and No-Pass

SYMBOL: RD

DEFINITION: Report Delayed

SYMBOL: W

DEFINITION: Withdrawal

Withdrawal from a class or classes shall be authorized through the last day of the 14th week of instruction or 75 percent of the time the class is scheduled to meet, whichever is less.

No notation ("W" or other) shall be made on the record of the student who withdraws during the first 4 weeks, or 30 percent of the time the class is scheduled, whichever is less.

Withdrawal between the end of the 4th week (or 30 percent of the time the class is scheduled to meet, whichever is less) and the last day of the 14th week of instruction (or 75 percent of the time the class is scheduled to meet, whichever is less) shall be authorized after informing the appropriate faculty. A student who remains in class beyond the 14th week or 75 percent of the time the class is scheduled shall be given a grade other than a "W," except in cases of extenuating circumstances.

After the last day of the 14th week (or 75 percent of the time the class is scheduled, whichever is less), the student may withdraw from class upon petition demonstrating extenuating circumstances and after consultation with the appropriate faculty. Students should obtain a petition in the Admissions and Records Office. Extenuating circumstances are verified cases of accidents, illness, or other circumstances beyond the control of the student.

Withdrawal after the end of the 14th week (or 75 percent of the time the class is scheduled, whichever is less) which has been recorded as "W." The "W" shall not be used in calculating units attempted nor for the student's grade point average. "W"s will be used as factors in progress probation and dismissal.

Military Withdrawal: The governing board of a district which decides to provide a withdrawal policy shall also adopt military withdrawal procedures consistent with the following:

"Military withdrawal" occurs when a student who is a member of an active or reserve United States military service receives orders compelling a withdrawal from courses. Upon verification of such orders, a withdrawal symbol may be assigned at any time after the period established by the governing board during which no notation is made for withdrawals. The withdrawal symbol so assigned may be a "W" or, if necessary to distinguish military withdrawals, may be a "MW." Military withdrawals shall not be counted in progress probation and dismissal calculations. "W"s incurred during the period between January 1, 1990, and the effective date of this paragraph that meet the definition of military withdrawal herein shall not be counted in progress probation and dismissal calculations and may be changed to "MW"s.

GRADES & GRADE CHANGES

The instructor of the course shall determine the grade to be awarded to each student in accordance with Board Rule 6702. The determination of the student's grade by the instructor is final in the absence of mistake, fraud, bad faith, or incompetency. The removal or change of an incorrect grade from a student's record shall only be done upon authorization by the instructor of the course.

In the case of fraud, bad faith, or incompetency, the College President will make the final determination concerning removal or change of grade.

No grade may be challenged by a student more than one year from the end of the term in which the course was taken; however, if a college's academic senate has determined that the period of time during which grades may be challenged should be more than one year, such longer period shall apply at that college.

NOTAS DE CALIFICACION Y CAMBIOS EN LAS NOTAS

El instructor de cada curso determinará la nota de calificación de cada estudiante de acuerdo a la Regla 6702. Las notas reflejan primordialmente el nivel de dominio logrado en relación con el material expuesto en clase. La determinación de la nota por el instructor es permanente a menos que se haya cometido un error, ocurra fraude, mala fe o exista incompetencia. La eliminación o el cambio de notas incorrectas solo se autorizará por el instructor de ese curso. Si existió fraude, mala fe o incompetencia, el estudiante podrá completar una Petición para el Cambio de Nota. La petición deberá ser entregada al Decano de Asuntos Estudiantiles. La determinación final se hará por el presidente del Colegio.

PREREQUISITE, COREQUISITE & ADVISORY

Many courses listed in the Schedule of Classes will indicate Prerequisite, Corequisite, or Advisory courses listed after the name of the course. These recommendations were made after careful consideration by the faculty of that discipline. Our faculty has determined that each prerequisite, corequisite, or advisory will prepare you to be successful when you are ready to enroll in the

next level course. L.A. Mission College follows the Los Angeles Community College District Policy on Prerequisites and state regulations that were designed to help you reach your goal.

TRANSCRIPTS

Upon written request from the student a copy of the student's academic record shall be forwarded to the student or his designated addressee promptly by U.S. mail or other responsible forwarding agency.

A student or former student shall be entitled to two free copies of the transcript of his or her record or to two free verifications of student records. Additional copies shall be made available to the student, or to an addressee designated by the student, at a cost of \$3. Students may request rush processing to expedite their request for a total fee of \$10. This option is subject to the college's ability to provide this service. Requests for transcripts or verifications may be obtained in the Office of Admissions and Records. Transcripts from another institution are not available for copying.

The student's transcript may be withheld if any library books or other library materials are charged to the student and are unreturned or if there are any unpaid fees or charges due to the College. The transcript may be withheld until these obligations of the student to the College are discharged.

District Information

District Policies

STUDENTS' STATEMENTS

Falsification of any record or signed statement or the withholding of information subjects the student to immediate suspension or expulsion.

INSTRUCTIONAL MATERIALS

Students may be required to provide instructional and other materials required for a credit or non-credit course. Such materials shall be of continuing value to a student outside of the classroom setting and shall not be solely or exclusively available from the District.

WITHDRAWAL

Students wishing to drop a class or withdraw from the college during the semester must do so by Internet. Failure to withdraw officially may result in an "F" grade. Students must withdraw on or before the 11th week (75 percent) in order to receive a "W." Students in short-term classes must withdraw before 75 percent of the course is completed. After the 11th week or 75 percent completion of the course, a student is assigned a letter grade ("A" through "F"). Instructors are not obligated to exclude a student for non-attendance. **IT IS THE STUDENT'S RESPONSIBILITY TO WITHDRAW OFFICIALLY.**

How to Drop Classes or Withdraw from College

1. Dropping classes or withdrawing from the college must be done online by the drop date deadlines.
2. You must have your STUDENT IDENTIFICATION NUMBER ready. Go to www.lamission.edu

and click on "register for classes" to access the STUDENT INFORMATION SYSTEM. Click on "Add/Drop Classes."

3. Once the class is dropped, print the page with the confirmation number. This will be your receipt to show the class was dropped.
4. Fees are not automatically refunded. Fee refunds must be requested from the Business Office if you drop classes or withdraw by the end of the second week (full-term classes). If you drop a class beyond the 2nd week of class (full-term classes), you will not receive a refund. Contact the Admissions and records office for refund deadlines on late-start and short-term classes.
5. You may also withdraw online before the 11th week or 75 percent completion of the class.
6. For special program classes, contact them directly to get information about dropping deadlines.

Withdrawal from Classes

THROUGH THE 3rd WEEK: No notation ("W" or other) will appear on the student's record if the class is dropped during the first three weeks of the semester (or 30 percent of the class for short-term classes).

THROUGH THE 11TH WEEK: A notation of "W" (withdrawal) is recorded on the student's record for classes dropped during the 4th through the 11th week of the semester.

AFTER THE 11TH WEEK: Students who remain in class beyond the 11th week (or 75 percent of the class for short-term classes) are given a grade by the instructor. **THAT GRADE CANNOT BE A "W" (withdrawal).**

THREE (3) REPEAT RULE

Effective summer 2012, course withdrawal ("W") or a substandard grade ("D," "F," or "NP") count as an attempt at a course. Only three attempts at any one course will be allowed, with some exceptions. Listed below are the new rules that all students need to know about.

- Students who drop or are excluded after the last day to drop without a grade of "W" will have a "W" appear on their transcript. The "W" will count as an attempt for that course.
- Deadlines to drop classes without a "W" are posted on the schedule of classes, available on the college website.
- A course in a student's transcript which currently shows a recorded "W" counts as an attempt for that course.
- Students will not be allowed to register for any course within the LACCD if there are three recorded attempts for that course in any combination of W, D, F, or NP grades.
- Add permits for a course within the LACCD will not be processed if there are three recorded attempts for that course in any combination of W, D, F, or NP grades.
- For courses specifically designated as "repeatable," students may repeat up to three times. (See Title 5 California Code of Regulations sections 55040, 55041, 58161)
- Where the student's number of enrollments in a course exceeds the allowable amount, the student may petition for an additional enrollment in cases of extenuating circumstances.

What students should do:

- Be sure you are academically ready for classes you enroll in.
- If you must drop a course, drop before the specified deadline for dropping a class without a grade of "W."

ACCESS TO RECORDS

The California Legislature passed S.B. 182 (Stull), which codifies provisions of the Education Code and the Federal statutes implementing the Family Educational Rights and Privacy Act of 1974 (Buckley Amendment). This permits students to inspect their personally identifiable records maintained by the College and permits access to these records only upon the student's request (other than to certain specified categories). Information on these laws and college procedures in implementing them may be obtained from the Associate Dean of Admissions, who serves as the College Records Officer. Copies of pertinent state and federal legislation are available for inspection.

Los Angeles Mission College considers the following information relating to a student to be directory information: student's name, city of residence, date of birth, major field of study, participation in officially recognized activities and sports, weight and height of members of athletic teams, dates of attendance, degrees and awards received, and the most recent previous educational agency or institution attended by the student. Students who do not wish any or all of the above categories of information to be given out should so indicate on their application at time of enrolling. Los Angeles Mission College uses the social security number as a student identification number. Students are asked to voluntarily provide their social security number for this purpose.

FAMILY EDUCATIONAL RIGHTS & PRIVACY ACT (FERPA) NOTIFICATION

The Family Educational Rights and Privacy Act (FERPA) affords students the following rights with respect to their educational records:

1. The right to inspect and review the student's educational records, including discipline records, within 45 days from the date the College receives a request for access.
 - Students may submit to the College Admissions Office written requests that identify the specific record(s) they wish to inspect. Within 45

days, the College Admissions Office will make arrangements for access and will notify the student of the time and place where the records may be inspected.

- Educational records are those records that are directly related to students and are maintained by the College. Students may not inspect educational records pertaining to parents' financial records and certain confidential letters or recommendations.
2. The right to request an amendment of the student's educational records that the student believes to be inaccurate, misleading, or otherwise in violation of the student's privacy rights.
 - With the exception of grade grievances which are handled through Administrative Regulation E-55, students may ask the College President or his/her designee to amend a record that they believe is inaccurate, misleading, or in violation of their privacy rights. A student seeking to amend an educational record should write to the College President and clearly identify the part of the record he/she wants changed and specify why it is inaccurate, misleading, or in violation of his/her privacy rights.
 - If the College President or his/her designee decides not to amend the record as requested by the student, the College, in accordance with section 99.21 of the Code of Federal Regulations and Section 76232 of the Education Code, will notify the student of the decision and of his/her right to a hearing.
 3. The right to consent to disclosures of personally identifiable information contained in the student's educational records, except to the extent that FERPA and California law authorize disclosures without consent.
 - If a student authorizes the release of his/her education record to a third party, he/she shall notify the College Admissions Office authorizing said release with a specific list of the information to be released.
- Federal and California law authorize certain disclosures of personally identifiable information without a student's written consent. One such exception is the disclosure of personally identifiable information to school officials with legitimate educational interests. School officials with legitimate educational interests are employees or agents of the Los Angeles Community College District who need to review educational records in order to fulfill their professional responsibilities.
4. The right to restrict disclosure of personally identifiable information that the College has designated as directory information which may be released without the written consent of the student.
 - Directory information may be disclosed without a student's consent unless the student has notified the college that he/she does not want all or portions of the directory information released. To do so, the student must submit the appropriate District form to the College Admissions Office requesting that some or all of the categories of directory information not be released without his/her consent. This form must be submitted in accordance with College policy.
 - Pursuant to Board Rule 5201.10, the Los Angeles Community College District has designated the following student information as directory information:
 - a. The student's name, city of residence, participation in officially recognized activities and sports, weight and height of members of athletic teams, dates of attendance, degrees and awards received, and the most recent previous educational agency or institution attended by the student.
 - b. Student employee records may be released in order to comply with collective bargaining agreements.

District Information

c. The names, addresses, and telephone numbers of students or former students may be released to the foundation for each college for college-related activities at the discretion of the College President, unless the student or former student has informed the College that such information should not be released. The release of this information is conditional upon the foundation's agreement that such information will be released in accordance with District policy and that information will not be released to third parties.

d. At the discretion of the College President, the names, addresses, and telephone numbers of students from the College may be released to heads of private and/or public institutions of higher education or their designees for the purpose of providing information to the student regarding transfer opportunities to those institutions, unless the student has indicated that such information should not be released. The release of this information will be conditional upon the institution's agreement that student privacy rights under federal and state law will be protected and that information will not be released to third parties.

5. The right to file a complaint with the U.S. Department of Education concerning alleged failures by the College to comply with the requirements of FERPA. The name and address of the office that administers FERPA is:

Family Policy Compliance Office
U.S. Department of Education
400 Maryland Avenue S.W.
Washington, DC 20202-4605

STUDENT RIGHT-TO-KNOW DISCLOSURE

In compliance with the Student Right-to-Know and Campus Security Act of 1990 (Public Law 101-542), it is the policy of the Los Angeles Community

College District and Los Angeles Mission College to make available its completion and transfer rates to all current and prospective students. Beginning in Fall 1996 a cohort of all certificate, degree, and transfer-seeking first-time, full-time students was tracked over a three-year period. Their completion and transfer rates are listed below. These rates do not represent the success rates of the entire student population at all California community colleges, nor do they account for student outcomes occurring after this three-year tracking period.

Based upon the cohort defined above, 28.2 percent attained a certificate, degree, or became "transfer-prepared" during a three-year period from Fall 1997 to Spring 2000. Students who are transfer-prepared have completed 56 transferable units with a GPA of 2.00 or better.

Based upon the cohort defined above, 29.8 percent transferred to another post-secondary institution (CSU, UC, or another California community college) prior to attaining a degree, certificate, or becoming "transfer-prepared" during a five-semester period from Spring 1998 to Spring 2000.

Further information about Student Right-To-Know Rates and how they should be interpreted can be found at the California Community Colleges Chancellor's Office Student Right-To-Know Disclosure website located at <http://srtk.cccco.edu/index.asp>

STUDENT GRIEVANCE PROCEDURE

The Student Grievance Procedure is to provide a prompt and equitable means for resolving student grievances. The grievance procedure may be initiated by a student or group of students who reasonably believe that he/she/they have been subject to unjust action or denied rights that adversely affect his/her/their status, rights, or privileges as a student. The grievance procedure is detailed in District Administrative Regulation E-55,

which is available to any student or applicant to the college in the Student Services Office and from the Campus Ombudsperson.

This grievance procedure does not apply to the challenge process for prerequisites, corequisites, advisories, and limitations on enrollment; alleged violations of sexual harassment; actions dealing with student discipline; alleged discrimination on the basis of ethnic group identification, religion, age, sex, color, sexual orientation, or physical or mental disability; an appeal for residency decision; or to eligibility, disqualification, or reinstatement of financial aid.

In addition, Section 76224 of the California Education Code provides the following:

"When grades are given for any course of instruction taught in a community college district, the grade given to each student shall be the grade determined by the instructor of the course and the determination of the student's grade by the instructor, in the absence of mistake, fraud, bad faith, or incompetency, shall be final."

The following steps should be taken to begin the grievance procedure:

Step I - Informal Resolution

All parties involved in a potential grievance should be encouraged to seek an informal remedy. The student shall make a reasonable effort to resolve the matter on an informal basis by:

1. Meeting with the person with whom the student has a grievance
2. Meeting with that person's immediate supervisor
3. Meeting with the College administrator of the area
4. Meeting with the College ombudsperson to explore student rights and responsibilities, receive assistance with an informal resolution, and submit a written "Statement of Grievance"

Step II - Formal Resolution

Students unable to resolve their grievance

through the informal process may file a "Formal Grievance Hearing Request Form" with the College ombudsperson. The College ombudsperson will provide students with information about the formal grievance hearing process and their rights and responsibilities in this process.

Students pursuing a formal grievance have the right to be represented by a student advocate who will assist students in the formal grievance process.

Additional information and assistance with the Student Grievance Procedure may be obtained from the Student Services Office.

Student Grievance Appeal Process

- A. Parties to the grievance may appeal the Grievance Hearing Committee's actions to the Grievance Appeals Committee. The Grievance Appeals Committee, consisting of the Chief Instructional Officer, the Chief Student Services Officer, the Academic Senate President (or designee), and one faculty member selected by the Academic Senate, shall review all appeals.
- B. Appeal of a Decision Not to Hold a Grievance Hearing. If the Grievant is dissatisfied with the decision of the Grievance Hearing Committee not to hold grant a Grievance Hearing, the Grievant may file a written appeal with the Grievance Appeals Committee (through the Chief Student Services Officer) within ten (10) instructional days after receipt of the Grievance Hearing Committee's decision or as soon thereafter as practicable. The appeal must state the specific basis on which it is made along with any supportive information. Within ten (10) instructional days of receipt of the appeal or as soon thereafter as practicable, the Grievance Appeals Committee will meet and review the Grievance Hearing Committee's decision not to hold a Grievance Hearing. Within ten (10) instructional days of its review of the appeal, the Grievance Hearing Committee will make a recommendation to the College President, through the Ombudsperson, on whether or not to hold a

Grievance Hearing. Within ten (10) instructional days of receiving the recommendation from the Grievance Appeals Committee, the College President will make a final decision and notify the Grievant and the Respondent, through the Ombudsperson, on whether or not there will be a Grievance Hearing.

If the College President decides that a Grievance Hearing should be held, a Grievance Hearing Committee with different membership shall hear the grievance.

- C. Appeal of a Grievance Hearing Committee's Recommendation After a Grievance Hearing. If the Grievant or Respondent is dissatisfied with the Grievance Hearing Committee's recommendations regarding the merits of the grievance, a written appeal may be filed with the Grievance Appeals Committee (through the Chief Student Services Officer) within ten (10) instructional days after receipt of the Grievance Hearing Committee's recommendation. The appeal must state the specific basis on which it is made along with any supportive information. Within ten (10) instructional days of receipt of an appeal or as soon thereafter as practicable, the Grievance Appeals Committee will meet and review the Grievance Hearing Committee's recommendations and the appeal. Within ten (10) instructional days of its review of the Grievance Hearing Committee's recommendations and the appeal, the Grievance Appeals Committee will make one of the following written recommendations to the College President: 1) uphold the Grievance Hearing Committee's recommendation, 2) reverse the Grievance Hearing Committee's recommendation or 3) order a new Grievance Hearing, because proper procedures were not followed. Within ten (10) instructional days of receipt of the Grievance Appeals Committee's recommendations, or as soon thereafter as practicable, the College President will review the Grievance Appeals Committee's

recommendations, make a final decision, and notify the Grievant and Grievance Hearing Committee, through the Ombudsperson, of that final decision.

- D. If, after meeting and reviewing an appeal, the Grievance Appeals Committee fails to make a determination regarding the appeal, the Ombudsperson will forward the appeal to the College President, who shall make a final decision on the appeal. The Grievance Appeals Committee will also provide the College President with a written explanation as to why it was unable to make a determination.

Role of the Chancellor

If the College President is a party to the action resulting in the grievance, the Chancellor or designee shall assume the responsibilities of the College President in the grievance process.

Role & Duties of the Ombudsperson

- A. The role of the Ombudsperson is that of a facilitator of the grievance process, and not that of an advocate for either the Grievant(s) or Respondent(s). Each college shall have an Ombudsperson.
- B. The Ombudsperson shall provide information to Grievant(s) and Respondent(s) concerning the grievance procedures at any stage in the grievance process.
- C. The Ombudsperson may collect information, documents and records pertinent to the case.
- D. The Ombudsperson may hold and facilitate meetings and discussions that may lead to a resolution of the grievance.
- E. The Ombudsperson may train the Student Advocates prior to the Student Advocates assuming the duties of the position.
- F. The Ombudsperson shall sit with the Grievance Hearing Committee and may answer questions upon request but shall not serve as a member or vote.
- G. During the formal hearing stage of the grievance process, the Ombudsperson shall coordinate

District Information

the preparation and conduct of the Grievance Hearing, including providing in-service training to committee members on hearing procedures and operation.

- H. The Ombudsperson shall ensure that the entire grievance process is conducted in an orderly, fair and respectful manner. The Ombudsperson shall have the authority to exclude from the hearing any individuals who fail to conduct themselves in an orderly, fair and respectful manner.
- I. The Ombudsperson shall be responsible for audio recording the Hearing and arranging for safe storage of the grievance file including the audio recording(s) and documents, for a period not less than seven (7) years.
- J. The Ombudsperson, shall assist the Grievant(s) in understanding the grievance procedures, filing the appropriate forms, meeting all the time lines of these procedures, communicating with college employees and officials and participating in the hearing process. (See Section 10 for non-student advocate options)

RECORDING DEVICES IN THE CLASSROOM

Section 78907 of the California Education Code prohibits the use of any electronic listening or recording device without prior consent of the instructor. Any student violating this section is subject to disciplinary action. Any non-student who willfully violates this section is guilty of a misdemeanor.

COMPLIANCE OFFICER

If students feel they have grounds for a grievance, they may contact the college President, who will help explain college rules and regulations, and, if a problem is resolvable, suggest the best method for resolving the problem. For additional information and a copy of Administrative Regulation E-55 (Student Grievance Procedures), see the College President, 818.364.7795.

OFICIAL DE ARBITRAJE

Si un estudiante cree que tiene motivos para formular una acusación, puede comunicarse con el presidente del colegio que le ayudara dándole una explicación de las reglas y procedimientos de la institución. Si el problema puede ser resuelto, le dara una sugerencia de cual es la mejor manera de resolverlo. Para obtener información adicional y para conseguir la formula E55 de las regulaciones administrativas (student grievance procedure), por favor de comunicarse a la oficina del presidente, 818.364.7795.

STANDARDS OF STUDENT CONDUCT & DISCIPLINARY ACTION

The Standards of Student Conduct and Disciplinary Action for violation of rules were established by the Board of Trustees of the Los Angeles Community College District on September 2, 1969. A student enrolling in one of the Los Angeles Community Colleges may rightfully expect that the faculty and administrators will maintain an environment in which there is freedom to learn. This requires that there be appropriate conditions and opportunities in the classroom and on the campus. As members of the college community, students should be encouraged to develop the capacity for critical judgment, to engage in a sustained and independent search for truth, and to exercise their rights to free inquiry and speech in a responsible, non-violent manner. Students shall respect and obey civil and criminal laws, and they shall be subject to legal penalties for violation of laws of the city, county, state, and nation. Student conduct in all of the Los Angeles Community Colleges must conform to District and college rules and regulations.

Violations of such rules are subject to the following types of disciplinary actions, which are to be administered by appropriate college authorities

against students who stand in violation. Each of the Los Angeles Community Colleges shall establish due process of law for administration of the penalties enumerated here. Penalties are listed in degree of severity but not as chronological administration. College authorities will determine which type of penalty is appropriate.

1. WARNING

Notice to the student that continuation or repetition of specified conduct may be cause for other disciplinary action.

2. REPRIMAND

Written reprimand for violation of specified rules. A reprimand serves to place on record that a student's conduct in a specific instance does not meet the standards expected at the college. A person receiving a reprimand is notified that this is a warning that continued conduct of the type described in the reprimand may result in formal action against the student.

3. REMOVAL BY INSTRUCTOR

An instructor may remove (suspend) a student from his or her class for the day of the incident and the next class meeting. During this period of removal, a Summary Investigation should take place as to determine the length of the suspension. Any classes missed during this process will be considered excused absences.

4. DISCIPLINARY PROBATION

Exclusion from participation in privileges or extracurricular college activities set forth in the notice of disciplinary probation for a specified period of time.

The imposition of disciplinary probation involves notification in writing of the reason for disciplinary probation to the student(s) or president of the student organization involved.

5. RESTITUTION

Reimbursement for damage or for

misappropriation of property. Reimbursement may take the form of appropriate service to repair or otherwise compensate for damage.

6. *SUMMARY SUSPENSION*

A summary suspension is for purposes of investigation. It is a means of relieving the tension of the student body or individual class due to a serious infraction of student behavior standards, removing a threat to the well-being of the students, or removing for the good order of the college a student or students whose presence would prevent the continued normal conduct of the academic community. Summary suspension is limited to that period of time necessary to insure that the purposes of the summary suspension are accomplished, and in any case, no more than a maximum of ten school days.

Summary suspension is a type of suspension other than that ordinarily invoked by the instructor in the classroom. The College President, appropriate administrator, or other staff member designated by the President may summarily suspend a student when he/she deems it necessary for the safety and welfare of the college.

7. *DISCIPLINARY SUSPENSION*

Disciplinary suspension follows a hearing based on due process of law. It shall be invoked by the College President, appropriate administrator, or other staff member designated by the President upon students for misconduct when other corrective measures have failed or when the seriousness of the situation warrants such action.

8. *EXPULSION*

An expulsion is a long-term or permanent denial of all campus privileges including class attendance. The President of the college and/or the Board of Trustees may expel a student who has been convicted of a crime arising out of a campus disturbance or, after a hearing by a campus body, has been found to have willfully disrupted the orderly operation of the campus. The President shall

submit periodic reports on all expulsion cases to the Superintendent and the Board of Trustees.

Violations of the Standards of Student Conduct are as follows:

2419 Smoking/Nonsmoking Policy:

The Chancellor shall adopt regulations to prohibit the smoking of tobacco, plant, or processed substance, or the use of comparable, personal, vapor-generating devices in the District's buildings, offices, and any other enclosed spaces throughout the District, and limit such activity to a maximum of four locations on any campus.

2420 Gun-Free Campuses: Possession or display of firearms of any kind shall not be allowed on the principal campuses of the District except by law enforcement officials, for theatrical performances, or by others that may have been issued a license or permit that allows the possession of a firearm on campus. This prohibition shall apply even where a firearm is not operational.

9803.10 Willful Disobedience: Willful disobedience to directions of college officials acting in the performance of their duties.

9803.11 Violation of College Rules and Regulations:

Violation of college rules and regulations, including those concerning student organizations, the use of college facilities, or the time, place, and manner of public expression or distribution of materials.

9803.12 Dishonesty: Dishonesty, such as cheating or knowingly furnishing false information to colleges.

9803.13 Unauthorized Entry: Unauthorized entry to or use of the college facilities.

9803.14 College Documents: Forgery, alteration, or misuse of college documents, records, or identification.

9803.15 Disruption of Classes or College Activities: Obstruction or disruption of classes, administration, disciplinary procedures, or authorized college activities.

9803.16 Theft of or Damage to Property:

Theft of or damage to property belonging to the college, a member of the college community, or a campus visitor.

9803.17 Interference with Peace of College:

The malicious or willful disturbance of the peace or quiet of any of the Los Angeles Community Colleges by loud or unusual noise, or any threat, challenge to fight, fight, or violation of any rules of conduct as set forth in this Article.

9803.18 Assault or Battery: Assault or battery, abuse, or any threat of force or violence directed toward any member of the college community or campus visitor engaged in authorized activities.

9803.19 Alcohol and Drugs: Any possession of controlled substances which would constitute a violation of Health and Safety Code Section 11350 or Business and Professions Code Section 4230; any use of controlled substances the possession of which are prohibited by same, or any possession or use of alcoholic beverages while on any property owned or used by the District or colleges of the District. "Controlled substances," as used in this section, includes, but is not limited to, the following drugs and narcotics:

- a. Opiates, opium, and opium derivatives
- b. Mescaline
- c. Hallucinogenic substances
- d. Peyote
- e. Marijuana
- f. Stimulants and depressants
- g. Cocaine

9803.20 Lethal Weapons: Possession, while on a college campus or at a college-sponsored function, of any object that might be used as a lethal weapon is forbidden by all persons except sworn peace officers, police officers, and other government employees charged with policing responsibilities.

9803.21 Discriminatory Behavior: Behavior while on a college campus or at a college-sponsored function inconsistent with the District's

District Information

non-discrimination policy, which requires that all programs and activities of the Los Angeles Community College District be operated in a manner which is free of discrimination on the basis of race, color, natural origin, ancestry, religion, creed, sex, pregnancy, marital status, sexual orientation, age, handicap, or veteran status.

9803.22 Unlawful Assembly: Any assemblage of two or more persons to do an unlawful act, or do a lawful act in a violent, boisterous or tumultuous manner.

9803.23 Conspiring to Perform Illegal Acts: Any agreement between two or more persons to perform an illegal act.

9803.24 Threatening Behavior: A direct or implied expression of intent to inflict physical or mental/emotional harm and/or actions (such as stalking) that a reasonable person would perceive as a threat to personal safety or property. Threats may include verbal statement, written statements, telephone threats or physical threats.

9803.25 Disorderly Conduct: Conduct that may be considered disorderly includes lewd or indecent attire, behavior that disrupts classes or college activities, breach of the peace of the college, or aiding or inciting other persons to breach the peace of college premises or functions.

9803.26 Theft or Abuse of Computer Resources: Theft or abuse of computer resources including but not limited to the following:

- a. Unauthorized entry into a file to use, read, or change the contents or for any other purpose
- b. Unauthorized transfer of a file
- c. Unauthorized use of another individual's identification or password
- d. Use of computing facilities to interfere with the work of a student, faculty member, or college official or to alter college or District records

e. Use of unlicensed software

f. Unauthorized copying of software

g. Use of computing facilities to access, send, or engage in messages which are obscene, threatening, or defamatory; present a clear and present danger; violate a lawful regulation; and/or substantially disrupt the orderly operation of a college campus

h. Use of computing facilities to interfere with the regular operation of the college or District computing system

9804 Interference with Classes: Every person who by physical force willfully obstructs or attempts to obstruct any student or teacher seeking to attend or instruct classes at any of the campuses or facilities owned, controlled, or administered by the Board of Trustees of the Los Angeles Community College District, is punishable by a fine not exceeding five hundred dollars (\$500) or imprisonment in a county jail not exceeding one year, or by both such fine and imprisonment.

9805 Interference with Performance of Duties of Employees: Action to cause, or attempt to cause, any employee of the District to do, or refrain from doing, any act in the performance of his or her duties by means of a threat to inflict any injury upon any person or property.

9805.10 Assault or Abuse of an Instructor: Assault or abuse of any instructor employed by the District in the presence or hearing of a community college student, or in the presence of other community college personnel or students, and at a place which is on District premises or public sidewalks, streets, or other public ways adjacent to school premises, or at some other place where the instructor is required to be in connection with assigned college activities.

9806 Unsafe Conduct: Conduct which poses a threat of harm to the individual and/or to others.

This includes, but is not limited to, the following types of conduct: unsafe conduct in connection with a Health Services Program (e.g., Nursing, Dental Hygiene, etc.); failure to follow safety direction of District and/or college staff; willful disregard of safety rules as adopted by the District and/or college; negligent behavior which creates an unsafe environment.

COLLEGES AS NON-PUBLIC FORUM

9901 The colleges of the Los Angeles Community College District are non-public forums, except for those portions of each college designated as Free Speech Areas by their respective college presidents. The Free Speech Areas are hereby designated as limited public forums, which designation may be removed and reverted to non-public forum designation by the Board of Trustees.

9902 Free Speech Areas: The College President shall designate an area or areas on the college campus as areas for free discussion and expression by all persons. A Free Speech Area may only be located where there is a normal flow of student traffic with unlimited accessibility. Necessary campus rules governing the operation of such areas are to be used. All such rules shall be applied equally and fairly to all persons desiring to use the Free Speech areas. No restriction shall be placed on subject matter, topics, or viewpoints expressed in Free Speech Areas.

9902.10 Responsibilities of Persons Using Free Speech Areas: All persons using the Free Speech Area of a college are expected to monitor the content of their speech such that the expression (1) is not obscene, libelous, or slanderous according to current legal standards, (2) does not create a clear and present danger of the commission of unlawful acts on community college premises, (3) is not violative of lawful community college regulations, (4) does not substantially disrupt the orderly

operation of the college. Any person who is found to have expressed speech in violation of this section may be subject to the sanctions applicable respectively to students, staff, faculty, or visitors.

9902.11 Distribution of Materials: Persons using a Free Speech Area shall be allowed to distribute petitions, circulars, leaflets, newspapers, miscellaneous printed matter, and other materials, subject to the following restrictions:

1. Such distribution shall take place only within the geographical limits of the Free Speech Area;
2. Any material being distributed which is discarded or dropped in or around the Free Speech Area other than in an appropriate receptacle must be retrieved and removed or properly discarded by those persons distributing the material prior to their departure from the Free Speech Area that day.
3. Persons distributing material shall not impede the progress of passers-by into taking the offered material.

9902.12 Forms of Speech: Persons using the Free Speech Area shall be entitled to exercise their speech privileges in any manner which does not violate the rules of conduct set forth in Article VII or in the Article; including but not limited to the use of printed materials and the wearing of buttons, badges, or other insignia, except that:

1. No means of amplification may be used, electronic or otherwise, which creates any noise or diversion that disturbs or tends to disturb the orderly conduct of the campus or classes taking place at the time;
2. No person using the Free Speech Area shall physically touch, strike or impeded the progress of passers-by;
3. No person using the Free Speech Area shall solicit donations of money, through direct requests for funds, sales of tickets, or otherwise, except where he/she is using the Free Speech Area on behalf of

and collecting funds for an organization which is registered with the Secretary of State as a non-profit corporation, or is an approved Associated Student Organization or Club.

9902.13 Time Allotments for Speech: The President of each college or his/her representative may set reasonable time restrictions on the use of the Free Speech Areas, in order to ensure that all persons are given equal access to the use of the Free Speech Area. If it appears to the President or his/her representative that granting extra time to a person for the use of the Free Speech Area will not impair equal access to the forum for all interested persons, such extra time shall be granted. Access to the Free Speech Area shall be granted on a weekly schedule on a first come, first served basis; however, priority shall be given to any person who has not yet used the Free Speech Area during a week over any persons who have already used the forum during that week. The times at which the Free Speech Area may be used shall be subject to reasonable campus regulations.

9903 Student Exercise of Free Speech in Areas Outside of Designated Free Speech Area: The President of each college may designate areas outside of the Free Speech Areas where students, faculty, and staff may exercise freedom of expression subject only to reasonable time, place and manner restrictions.

9903.10 Bulletin Boards: Students shall be provided with bulletin boards for use in posting student materials at campus locations convenient for student use. The location and number of such bulletin boards shall be determined by the College President or his/her representative. Each college may have bulletin boards. The use of the bulletin boards shall be open to use only by the students or recognized student organizations and shall be based on a first come, first served basis. Posting of material on bulletin boards shall be

subject to the limitations concerning the manner of exercising students' right of free expression in Free Speech Areas pursuant to Section 9902.10. All materials displayed shall clearly indicate the author or agency responsible for its production and shall be dated with the date of posting by the College President's designee. The President of each college shall prescribe reasonable lengths of time during which such printed materials may be posted on the bulletin boards with the object of assuming fair access to the bulletin boards for all students.

9903.11 Posting Areas: The President of each college, or his/her representative, may designate areas other than the bulletin boards for display of material.

9904 Student Use of Areas Not Designated for Free Speech Activities: Student use of classrooms, buildings, facilities and grounds not designated as Free Speech Areas or otherwise designated for student free speech exercises in accordance with this article shall be governed by the rules and regulations established pursuant to Article X, relating to student activities and events.

9905 Visitor Use of Areas Not Designated Free Speech Activities: Visitor use of any areas, classroom, buildings, facilities and grounds not designated as Free Speech Areas is subjected to the Civic Center Permit rules set for in Chapter VII, Article 2 of these Board Rules.

91204 Non-Student on Campus Without Lawful Business Theron: Any person who is not a student, officer, or employee of the District, or one who is not required by his/her employment to be on a campus or any other facility owned, operated, or controlled by the Board of Trustees, shall not be allowed on any campus or any facility owned, operated, or controlled by the Board of Trustees, unless he/she has lawful business thereon. "Lawful business" means a reason for

District Information

being present which is not otherwise prohibited by statute, by ordinance, or by regulation adopted pursuant to statute or ordinance.

POLICY ON ILLEGAL FILE SHARING

Unauthorized distribution of copyrighted material, including unauthorized peer-to-peer file sharing, may subject students to civil and criminal liability. Civil liability for copyright infringement may include payment of monetary damages to the copyright owner. Criminal penalties for copyright infringement may include fines up to \$250,000 and imprisonment up to ten years. Students who violate the District's computing facilities usage policy (LACCD Administrative Regulation B-28) may also be subject to college disciplinary action, including, but not limited to, suspension or expulsion.

NON-DISCRIMINATION POLICY

All programs and activities of the Los Angeles Community College District shall be operated in a manner which is free of discrimination on the basis of ethnic group identification, race, color, national origin, ancestry, religion, creed, sex, pregnancy, marital status, medical condition (cancer related), sexual orientation, age, physical or mental disability (including AIDS), or veteran status (Reference: Board Rule 1202).

Non-Discrimination Policy Compliance Procedure

In order to ensure nondiscrimination policy compliance at Los Angeles Mission College, please direct inquiries to the President of the college, 818.364.7795. Matters involving Section 504 may be directed to the Director of Disabled Students Programs and Services at 818.364.7734. In addition, inquiries may be directed to the District Office of Diversity Programs at 213.891.2315.

POLITICA NO DISCRIMINATORIA

Todos los programas y actividades de los colegios de la comunidad de Los Angeles se administrarán de

una manera que no discrimine respecto a la identidad de grupos étnicos, raza, color, nacionalidad, origen, ascendencia, religión, credo, sexo, embarazo, estado civil, condición médica (relacionada con cáncer), preferencia sexual, edad, incapacidad mental o física (incluyendo SIDA) o el ser veterano.

Politica De Acuerdo Con Los Procedimientos De Igualdad De Oportunidades

Para cumplir con la póliza no discriminatoria en Los Angeles Mission College, dirija sus preguntas a la oficina del Presidente, 818.364.7795. Para la Sección 504, dirijase al Coordinador del Programa de Personas Incapacitadas, al 818.364.7734. Además, puede dirigir sus preguntas a la oficina "Diversity Programs," 213.891.2315.

SEXUAL ASSAULT

The Los Angeles Community College District is committed to providing a safe environment for its students, faculty, and staff. The Los Angeles Community College District Board of Trustees condemns any act of sexual assault committed on any of its facilities. In the event of sexual assault committed on grounds or in facilities maintained and/or used by the District, any victim of a sexual assault who is one of the District's students, faculty, staff, or visitors shall promptly receive appropriate treatment and full and accurate information. Individuals who commit sexual assault while on properties within the control of the District shall be subject to appropriate criminal prosecution and/or District disciplinary procedures.

Confidentiality is fundamental to all aspects of cases dealing with sexual assault. The names of sexual assault victims shall not be revealed by persons responsible for implementing and enforcing the provisions of this Chapter, except with the consent of the victim. Victims of sexual assault may obtain a list of referrals to community agencies from the College Sheriff's office.

POLITICA DE ABUSO SEXUAL

El "Community College District," se compromete a proveer un ambiente seguro a los estudiantes, visitantes y personal. Cualquier incidente de abuso sexual debe ser reportado de inmediato al departamento de policía del colegio al 818.364.7843. La palabra "abuso sexual," que se encuentra registrada bajo el código de educación de California en la sección 67385(d), incluye amenazas de violencia sexual. Cualquier persona acusada de abuso sexual en el colegio puede ser sujeto a penalización bajo las leyes de California. Los estudiantes también pueden ser sujetos a disciplina bajo los procedimientos disciplinarios para estudiantes. La política de acoso sexual puede ser aplicada y se puede comunicar con el presidente del colegio al número de teléfono 818.364.7795. Esta información se mantendrá confidencial.

SEXUAL HARASSMENT POLICY

The Los Angeles Community College District has a policy which provides formal and informal procedures for resolving complaints. Copies of the policy and procedures may be obtained from the Compliance Officer by calling 818.364.7701 or by calling the District Office of Diversity Programs at 213.891.2315. It is the policy of the Los Angeles Community College District to provide an educational, employment, and business environment free from unwelcome sexual advances, requests for sexual favors, and other verbal or physical conduct or communications constituting sexual harassment. Employees, students, or other persons acting on behalf of the District who engage in sexual harassment as defined in this policy or by state or federal law shall be subject to discipline, up to and including discharge, expulsion, or termination of contract.

POLITICA DE ACOSO SEXUAL

La política de "Los Angeles Community College District," es proveer un ambiente educativo, de empleo y de trabajo excmpto de avances sexuales, solicitación de favores sexuales o cualquier otra conducta inapropiada física o verbal o comunicación que se envuelva en acoso sexual. Los empleados, estudiantes u otras personas que representen el Distrito y que acosen a alguien sexualmente pueden ser de acuerdo a la política de discriminación sexual o del Estado o la ley federal sujetos a disciplina que puede incluir: despido, expulsión o finalización del contrato. Las reglas y procedimientos específicos para reportar acusaciones de acoso sexual que buscan una solución, se encuentran en el libro "Board of Rules" en el capítulo quince. "Los Angeles Community College District," tiene una política que provee procedimientos formales e informales para resolver quejas. Copias de esta política y sus procedimientos pueden obtenerse del presidente del colegio, al número de teléfono 818.364.7795, también puede comunicarse con el "Senior Director" de educación y apoyo a los servicios del estudiante (Educational and Student Support Services) al teléfono 213.891.2279 o a la oficina de diversificación de programas (Diversity Programs) al teléfono 213.921.2315. Cualquier miembro del "Community College" y que incluye: estudiantes, profesorado y personal y que cree, percibe o en realidad experimenta un comportamiento que pudiera significar acoso sexual, tiene el derecho de pedir ayuda del colegio. Todo empleado tiene la responsabilidad de reportar tal conducta cuando envuelve al estudiante al oficial de arbitraje. Se les informa a los posibles denunciantes que soluciones por la ley civil y administrativas y que incluyen pero no se limitan a interdictos judiciales, órdenes de restricción u otras órdenes pueden estar disponibles.

Academic Freedom

Academic freedom insures the faculty's right to teach and the student's right to learn. The discussion

of sexual ideas, taboos, behavior, or language which is an intrinsic part of the course content does not constitute sexual harassment. The Board of Trustees reaffirms its commitment to academic freedom but recognizes that academic freedom does not allow discriminatory or harassing conduct.

Definition of Sexual Harassment

Harassment occurs when unwelcome sexual advances, requests for sexual favors, and other verbal or physical conduct of a sexual nature:

1. Is made either explicitly or implicitly a term or condition of an individual's employment, academic status, or progress;
2. Has the purpose or effect of having a negative impact upon the individual's work or academic performance, or creating an intimidating, hostile, or offensive work or educational environment;
3. Is used as the basis for employment or academic decisions or any decision affecting the individual regarding benefits and services, honors, programs, or activities available at or through the District, regardless of submission to or rejection of such conduct.

For the purpose of further clarification, sexual harassment may include, but is not limited to, the following types of conduct:

- Making unwelcome, unsolicited written, verbal, physical, and/or visual contact with sexual overtones
- Verbal harassment or abuse
- Unwelcome pressure for dates
- Disparaging remarks about one's gender
- Sexist jokes about one's clothing, body, or sexual activities
- Deliberate blocking of physical movement
- Obscene gestures
- Demands for sexual favors accompanied by implied or overt threats
- Display of sexually suggestive objects, cartoons, or posters
- Request for sex in exchange for grades, earned

or deserved; letters of recommendation; or employment opportunities

- Making reprisals, threats of reprisal, or implied threats of reprisal following rejection of harassment by suggesting or actually withholding grades, a promotion recommendation, scholarship recommendation, or a poor performance evaluation

Complaint Procedure

When an employee, student, or other individual feels, perceives, or has actually experienced conduct that may constitute sexual harassment, it is that person's responsibility to inform the individual engaging in such conduct that the behavior being demonstrated is offensive and must stop. When it is not possible or practical to confront the person directly, or if the situation continues, the conduct must be reported to the Sexual Harassment Compliance Officer at the work site. Complaints may be filed by persons other than the person who is the recipient of the unwanted conduct.

The Sexual Harassment Compliance Officer shall receive the complaint, make notes, conduct a preliminary investigation, and notify the alleged offender, the appropriate college President or District administrator, and the Director of the Office of Affirmative Action Programs within five (5) business days of a potential violation of this policy. During the process of the investigation, the complainant/victim and the alleged offender have the right to be represented, at all times, by a representative of their choice.

Each college President shall designate a Sexual Harassment Compliance Officer. The Chancellor shall designate the SHCO at the Educational Services Center. The District shall provide annual notice of the summary of this policy to each District employee. A summary of the policy shall be published in each college catalog and class schedule.

The Director of Diversity Programs shall be assigned the responsibility of District compliance. The Director shall provide mandatory education and

District Information

training programs on sexual harassment as stipulated in this policy.

Necessary forms to file a complaint of sexual harassment may be obtained from the Sexual Harassment Compliance Officer at the site and from the Office of the Vice President of Student Services. Anyone who believes that he/she is a victim of sexual harassment may also call 213.891.2315.

The entire policy and procedures shall be prominently posted with other official District announcements.

Pre-Complaint Questionnaire

Prior to filing a formal complaint, the complainant must pursue informal resolution by filing a pre-complaint questionnaire. This process is limited to 30 days.

False Allegations

Anyone who files a pre-complaint questionnaire or a complaint in which he/she knowingly makes false allegations of facts shall also have violated this policy and shall be subject to applicable disciplinary action.

Formal Complaint

If an informal resolution is not reached within thirty (30) days, the formal process will begin at the request of the complainant. In conducting the investigation, the Sexual Harassment Compliance Officer (SHCO) will take every reasonable step to ensure due process for all parties. The Compliance Officer shall, within the prescribed time frame, make appropriate notification to the complainant, the alleged offender, and to the District administration.

Within sixty (60) calendar days, the SHCO shall complete the investigation and provide a written report to the college President at his/her college site, or at the District office, the Vice Chancellor or the Chancellor. A copy of the report shall be sent to the Director of Diversity Programs.

The College President or, at the District office, the Vice Chancellor or the Chancellor, shall

independently assess the investigative report and render a decision. Prior to making the decision, the alleged offender with a representative of his/her choice shall have the opportunity to make an oral statement within fifteen (15) calendar days from the receipt of the SHCO report.

By certified mail, a written decision shall be mailed to the complainant and to the alleged offender, with a copy to the Director of Diversity Programs.

Appeal

If the complainant/victim is not satisfied with the Written Decision he/she may appeal to the District's Board of Trustees by submitting a written appeal to the Chancellor's Office within fifteen (15) days. The appeal shall state with particularity the basis for the appeal.

The Chancellor shall present the written appeal, the Written Decision and the investigative report to the Board of Trustees in closed session.

The Board of Trustees' decision shall be the District's Final Written Decision. The complainant/victim has the right to file a written appeal with the State Chancellor's Office of the California Community Colleges within thirty (30) days of this Final District Decision.

Additional Remedies

The complainant or alleged victim may pursue independently civil law remedies, including but not limited to injunctions, restraining orders, or other orders. An individual who believes that he/she is the victim of sexual harassment may also file a complaint with the Department of Fair Employment and Housing, the Equal Employment Opportunity Commission, the Office for Civil Rights, or the United States Department of Education, whether or not the complainant chooses to utilize the District's internal procedure.

Confidentiality

All persons involved in investigation of complaints shall maintain the confidentiality of the matters discussed, except as may be required or permitted by law, which include the rules and regulations of the District. A complete record of each complaint and investigation shall be kept by the Director of Diversity Programs. The Written Decision regarding the results of the investigation shall be placed in the personnel file of each employee involved as an alleged offender or alleged victim or complainant.

Disciplinary Procedure

Disciplinary action, if any, shall be pursued in accordance with the alleged offender's due process rights, as defined by law, the Board Rules, the Personnel Commission, and/or any applicable collective bargaining agreement or Memoranda of Understanding.

Disciplinary action shall include, without limitation, verbal warning, probation, suspension or expulsion, letters of reprimand, Notices of Unsatisfactory Service, suspensions, demotions, or dismissals.

Retaliation

Anyone who makes a complaint or participates in any action authorized under this policy shall not be subject to retaliatory action of any kind by any employee or student of the Los Angeles Community College District.

OMBUDSPERSON'S ROLE

The President of each college appoints an ombudsperson to assist students with resolving problems, concerns, and complaints through informal means. If a problem cannot be resolved informally, the student may file a grievance under Administrative Regulation E-55 (Student Grievance Procedures). The ombudsperson will assist the

student to prepare a case under this policy and present it to the Grievance Hearing Committee.

An ombudsperson handles complaints (hears and informally addresses problems, concerns, and complaints; opens channels of communication; serves as a neutral third party in conflict resolution; and seeks fair and equitable solutions to problems), provides information, and makes referrals to other campus resources as necessary.

DIVERSITY PROGRAM

The policy of the Los Angeles Community College District is to implement equal opportunity to all qualified employees and applicants for employment without regard to race, color, national origin, ancestry, religion, creed, sex, pregnancy, age, disability, marital status, medical condition (cancer related), sexual orientation, or veteran status. Positive action will be taken to ensure that this policy is followed in all personnel practices, including recruitment, hiring, placement, upgrading, transfer, demotion, treatment during employment, rate of pay or other forms of compensation, selection for training, layoff, or termination. Inquiries regarding equal opportunity practices at Los Angeles Mission College should be directed to the college Compliance Officer located in the Campus Center (818.364.7701).

DRUG-FREE ENVIRONMENT

Los Angeles Mission College adheres to, supports, and is in full compliance with requirements that maintain our college as a drug-free institution of higher education.

Standards of Conduct

On September 5, 1990, the Board of Trustees adopted the following standards of conduct: Students and employees are prohibited from unlawfully possessing, using, or distributing illicit drugs and alcohol on district premises, in district vehicles, or as part of any activity of the Los Angeles Community College District.

Legal Sanctions

Federal laws regarding alcohol and illicit drugs allow for fines and/or imprisonment. Other legal problems include the loss of driver's license and limitations of career choices.

Health Risks

Health risks associated with the abuse of controlled substances include malnutrition, damage to various organs, hangovers, blackouts, general fatigue, impaired learning, dependency, disability, and death. Both drugs and alcohol may be damaging to the development of an unborn fetus.

Other Risks

Personal problems include diminished self-esteem, depression, alienation from reality, and thoughts of suicide. Social problems include loss of friends, academic standing, and co- and extracurricular opportunities; alienation from and abuse of family members; and chronic conflict with authority. Economic problems include loss of job, financial aid eligibility, homes, savings, and other assets.

Students should contact the Student Health Center or the campus Counseling Office for assistance and referrals; employees should contact the Los Angeles Community College District Employee Assistance Program.

Disciplinary Action

Violation of Board Rule 9803.19 shall result in student discipline, imposed in accordance with the Student Discipline Procedures as stated in Board Rule 91101. Furthermore, institutional policies and practices may impose disciplinary sanctions on students and employees consistent with local, state, and federal law, up to and including expulsion, termination of employment, and referral for prosecution for violations of the standard of conduct.

The Los Angeles Community College District is committed to drug- and alcohol-free campuses, and we ask you to share in this commitment and dedication.

Counseling, Treatment & Rehabilitation

The following resources are available for the treatment of alcohol and drug dependence and abuse:

- Los Angeles Community College District Employee Assistance Program
818.907.7701 or 800.521.9944
- National Council on Alcoholism and Drug Dependence
213.384.0403 or 818.997.0414
- Los Angeles County Drug Abuse Program
213.624.DRUG
- Alcoholics Anonymous
213.387.8316 or 818.988.3001
- Cocaine Anonymous
213.839.1141 or 818.988.1777
- Narcotics Anonymous
213.283.1745 or 818.997.3822
- Families Anonymous
800.736.9805

SMOKING POLICY

In accordance with Board Rule 9804, smoking is permitted in designated areas only.

CAMPUS CRIME REPORT

Los Angeles Mission College's general statistics and crime can be viewed at the following URLs:

GENERAL INFORMATION

<http://nces.ed.gov/ipeds/cool/InstDetail.asp?UNTID=117867>

CRIME

<http://ope.ed.gov/SECURITY/instDetail.asp?UNTID=117867> then click on Criminal Offenses, Hate Offenses, or Arrests.

CAMPUS SECURITY

The campus Sheriff's office personnel are responsible for the safety and well being of staff, faculty, and students and for the security of college property and facilities (818.364.7843).

CAMPUS SECURITY ESCORT

Escorts can be arranged 24-hours a day through the Sheriff's office.

Graduation Information



Graduation Requirements

The Board of Governors of the California Community Colleges has authorized the Los Angeles Community College District Board of Trustees to confer Associate Degrees and Certificates of Achievement.

The awarding of an Associate Degree symbolizes a successful attempt on the part of the college to lead students through patterns of learning experiences designed to develop certain capabilities and insights. Among these are the ability to think and to communicate clearly and effectively both orally and in writing; to use mathematics; to understand the modes of inquiry of the major disciplines; to be aware of other cultures and times; to achieve insights gained through experience in thinking about ethical problems; and to develop the capacity for self-understanding. In addition to these accomplishments, the student should possess sufficient depth in some field of knowledge to contribute to lifetime interest.

The following requirements apply to all students.

Continuing students with uninterrupted attendance and demonstrating satisfactory progress, exclusive of summer and winter sessions, should refer to the graduation requirements listed in the catalog in effect at the time of their initial enrollment (catalog rights). A continuing student is one who has completed a minimum of one course per semester, except that completion with a "W" will be accepted for one semester only. Students who interrupt their attendance become subject to any new requirements which are in effect at the time they re-enroll.

LATE PETITIONS: Students, who petition to graduate after the deadline, will receive a graduation date of the semester that the petition is received. The permanent record and diploma will reflect the semester date when the student petitioned. A transcript memo will reflect the date that the AA degree was granted.

- I. Unit Requirement - A minimum of 60 degree-applicable units of course credit in a selected curriculum. One credit hour of community college work is approximately three hours of recitation, study, or laboratory work per week throughout a term of 16 weeks.
- II. Scholarship Requirement - A "C" (2.00) grade point average or better in all work attempted.
- III. English and Math Competency Requirement (Title 5) - Students must demonstrate competence in reading, and written expression, and in mathematics. The following courses and examinations are approved to meet the competency requirement for the Associate Degree in Board Rule 6201.12:

- A. The competency requirement in reading and written expression may be met by completion of one of the following courses (or its equivalent at another college) with a grade of "C" or better:
 1. English 101
 2. In meeting the reading and written expression competency requirement, course work is the primary measure of competency. However, competency may be met through credit-by-examination, as determined by the individual colleges.
- B. The competency requirement in mathematics may be met by completion of one of the following:
 1. Completion of one of the following courses (or its equivalent at another college) with a grade of "C" or better: Mathematics 123C, 125 or any higher level mathematics course with a prerequisite of Mathematics 125 or its equivalent
 2. A score of 3 or higher on one of the following AP Exams: Calculus AB, Calculus BC, Statistics
 3. Completion of the college assessment exam in Mathematics and achieve a score determined comparable to satisfactory completion of Intermediate Algebra (that is, placement in a Math course above Math 125 level)

- IV. Residence Requirement - Completion of at least 12 units of work in residence at the college awarding the degree. Exceptions may be made under special circumstances.
 - V. Major Requirements - A minimum of 18 semester units in a major or area of emphasis. Each major course must be completed with a grade of "C" or better.
 - VI. General Education Requirement: Students must complete one of the following general education plans: Los Angeles Mission College General Education Plan: this plan may NOT be used to meet the Associate Degree for Transfer (ADT) general education requirements, California State University General Education Breadth Plan (CSUGE Plan), Intersegmental General Education Transfer Curriculum.
- Please see a counselor to determine the best option.



Graduation Information



U.S. Department of Education Disclosure Regulations Regarding Programs Leading to Gainful Employment

To qualify for federal financial aid students must declare participation in a program that leads to a degree (associate, bachelor, graduate or professional) or in a certificate program that prepares students for employment. Effective July 1, 2011, the U.S. Department of Education (Federal Regulations 75-FR66832) has established guidelines requiring that community colleges disclose specific information regarding programs that lead to gainful employment in a recognized occupation. Information includes but is not limited to occupational profiles, program costs, employment projections, number of students who complete the program and time to completion of

the program. In accordance with these regulations, a website is provided by Los Angeles Mission College which provides this information: www.lamission.edu/careers/programs.aspx

ADDITIONAL AND CONCURRENT ASSOCIATE DEGREE REQUIREMENTS

Additional Associate Degrees: Students who have previously earned an associate degree from a United States regionally accredited institution will be granted an additional associate degree when the following requirements have been met:

1. Pursuant to catalog rights, described in Board Rule 6202, completion of all current degree requirements – i.e., scholarship, residency, competency, general education and major requirements.

2. Completion of a minimum of six (6) new units in a major. Major course requirements completed in previous degrees awarded can be used again for additional degrees.
3. All courses that count towards the associate degree major or area of emphasis must be satisfactorily completed with a grade of "C" or higher or "P" (pass).
4. There is no limit to the number of additional associate degrees that can be awarded provided that all the above requirements have been met.

Concurrent degrees: Concurrent degrees are degrees awarded in the same semester. Students may petition and be awarded concurrent associate degrees in different majors if the following criteria are met:

1. Pursuant to catalog rights, described in Board Rule 6202, completion of all current degree requirements: scholarship, residency, competency, general education and major requirements.
2. There is no maximum number of concurrent degrees that a student may be awarded.
3. If a course is a major requirement for each concurrent degree, it may be applied toward satisfaction of each major degree requirement.
4. Completion of the General Education requirements for one associate degree will fulfill the general education requirements for concurrent degrees, if the same general education pattern applies to the additional degree. If each degree requires the completion of different general education patterns, the general education pattern of each degree must be fulfilled. Courses may be applied toward the general education requirements for each concurrent degree.
5. All courses that count towards the associate degree major or area of emphasis must be satisfactorily completed with a grade of "C" or higher or "P" (pass).
6. The LACCD does not offer double majors.
<http://www.laccd.edu/Board/Pages/Board-Rules.aspx>

ASSOCIATE DEGREE – GENERAL EDUCATION REQUIREMENTS 2016-2017

General Education Requirements: Minimum of 21 semester units.

Major Requirements: Minimum of 18 units in a single or related field. Effective for all students entering Fall 2014 or later, each course counted towards the major or area of emphasis requirement must be completed with a “C” (2.0 or equivalent) or better.

THIS FORM IS SUBJECT TO CHANGE EACH YEAR: Please see a counselor and check the college catalog for specific major requirements.

A. Natural Sciences

Lab courses are underlined.

3 semester/4 quarter units

Anatomy	<u>1</u>
Anthro	101
Astron	1, <u>5</u>
Biology	<u>3, 5, 6, 7, 40</u>
Chem	<u>51, 52, 65, 101, 102, 211, 212</u>
EarthSci	<u>1, 2</u>
EnvSci	2
Fam&CS	21
Geog	1, 14, <u>15</u>
Geology	1
Micro	<u>20</u>
Ocean	1
PhysSc	1, <u>14</u>
Physics	<u>6, 7, 37, 38, 39</u>
Physiol	<u>1</u>
Psych	2

B. Social & Behavioral Sciences

6 semester/8 quarter units

B1. American Institutions
(3 semester units)

AfroAm	4
Chicano	7, 8
Econ	10
History	11, 12
PolSci	1

B2. Social & Behavioral Sciences
(3 semester units)

AdmJus	1, 4
AfroAm	2, 4
Anthro	102
Bus	1, 5
Chicano	2, 7, 19, 20, 44, 47, 71
ChDev	1
Econ	1, 2, 10
Educ	203
Fam&CS	6, 31, 91
Geog	2, 7, 14
History	1, 2, 11, 12, 86
Law	1
PolSci	2, 5, 7
Psych	1, 13, 14, 41, 52
Soc	1, 2, 3, 4, 11, 24, 28, 31

C. Humanities

3 semester/4 quarter units

AfroAm	2
Anthro	104, 121
Art	92, 101, 102, 103, 105, 109, 111, 201, 300, 501, 502, 700
ArtHist	161
Chicano	37, 42, 44, 46, 52, 54, 58
Cinema	3, 4
DanceStud	805
English	102, 127, 203, 205, 206, 208, 240
French	1, 2
History	86
Human	1, 2, 3, 30, 31
IntrDgn	104
Italian	1, 2
Linguistics	1
Music	101, 111, 141, 411
Philos	1, 14, 20, 33
Photo	10, 11, 47
Portgse	1, 2
Spanish	1, 2, 3, 4, 5, 6
Theater	100, 114, 200, 271, 300

D. Language & Rationality

6 semester/8 quarter units

D1. English Composition*#
(Min. 3 semester units)

ESL	8
English*	28, 101

D2. Communication &
Analytical Thinking**
(Min. 3 semester units)

Comm	101, 102, 121, 151 (previously Speech)
CoSci	401, 484
English	102, 103
LibSci	101
Math**	115, 121, 123B, 123C, 125, 129B, 215, 227, 238, 240, 245, 260, 265, 266, 267, 270, 272, 275
Philos	5, 6, 9, 20
Psych	74

E. Health & Kinesiology

3 semester/4 quarter units

E1. Health Education
(one course minimum)

Health	8, 11
KinMaj	101

E2. One Physical Education
Activity (1 semester/1
quarter unit minimum)

DanceTq	121, 141, 142, 462
KinAth	503-564
Kinesiology	35-552 (previously PE)

*English competency can be met
by completing English 101 with a
“C” (2.0) or better.

**Math competency can be met by
completing Math 123C, 125 or a
higher Math course with a grade
of “C” (2.0) or better OR Math
placement above intermediate
algebra level.

Graduation Information



THREE (3) REPEAT RULE

Effective summer 2012, course withdrawal ("W") or a substandard grade ("D," "F," or "NP") count as an attempt at a course. Only three attempts at any one course will be allowed, with some exceptions. Listed below are the new rules that all students need to know about.

- Students who drop or are excluded after the last day to drop without a grade of "W" will have a "W" appear on their transcript. The "W" will count as an attempt for that course.
- Deadlines to drop classes without a "W" are posted on the schedule of classes, available on the college website.
- A course in a student's transcript which currently shows a recorded "W" counts as an attempt for that course.
- Students will not be allowed to register for any course within the LACCD if there are three recorded attempts for that course in any combination of W, D, F, or NP grades.
- Add permits for a course within the LACCD will not be processed if there are three recorded attempts for that course in any combination of W, D, F, or NP grades.
- For courses specifically designated as "repeatable," students may repeat up to three times. (See Title 5 California Code of Regulations sections 55040, 55041, 58161)
- Where the student's number of enrollments in a course exceeds the allowable amount, the student may petition for an additional enrollment in cases of extenuating circumstances.

What students should do:

- Be sure you are academically ready for classes you enroll in.
- If you must drop a course, drop before the specified deadline for dropping a class without a grade of "W."

Degrees & Certificates

DISCIPLINES	ADT	AA	AS	Cert Achieve	Cert Accompl
ACCOUNTING		X			
ADMINISTRATION OF JUSTICE	X		X		
Probation/Correction Officer				X	
Basic Police Academy Prep					X
ART		X			
Art, Gallery and Museum Studies		X			
Painting		X			
Studio Arts	X				
BIOLOGY	X		X		
BUSINESS ADMINISTRATION	X	X			
CHICANO STUDIES		X			
CHILD DEVELOPMENT		X		X	X
Early Childhood Education (degree for transfer)	X				
Specializing in Preschool		X		X	
Specializing in Bicultural/Bilingual Preschool		X		X	
Specializing in Infant/Toddler		X		X	
Specializing in School-Age Care		X		X	
Specializing in Family Child Care		X		X	X
Specializing in Special Needs		X		X	
Child Dev in Administration					X
COMMUNICATION STUDIES	X				
COMPUTER APPLICATIONS & OFFICE TECHNOLOGIES		X			
Communications					X
Computer Applications					X
Office Assistant					X
COMPUTER SCIENCE – INFORMATION TECHNOLOGY		X			
CSIT - Business Emphasis		X			
Microcomputer Applications Management				X	X
Microcomputer Programming				X	
Cyber Security Associate					X
CSU CERTIFICATE OF ACHIEVEMENT				X	

ADT is Associate Degree for Transfer
AA is Associate of Arts
AS is Associate of Science

DISCIPLINES	ADT	AA	AS	Cert Achieve	Cert Accompl
CULINARY ARTS		X		X	
Baking Specialist I					X
Baking Specialist II					X
Culinary Specialist I					X
Culinary Specialist II					X
Restaurant Management		X		X	X
ELEMENTARY TEACHER EDUCATION	X				
ENGLISH	X	X			
FAMILY & CONSUMER STUDIES					
Family Studies		X			
Foods & Nutrition		X			
Gerontology		X		X	
Introduction to Hospitality					X
GENERAL STUDIES		X			
Arts & Humanities		X			
Communication & Literature		X			
Natural Sciences		X			
Social & Behavioral Sciences		X			
HEALTH OCCUPATIONS					
Health Occupations Fundamentals					X
HEALTH SCIENCES			X		
HUMANITIES		X			
IGETC Certificate of Achievement			X		
INTERIOR DESIGN		X		X	
Introduction to Interior Design					X
Introduction to Space Planning					X
Technology & Interior Design					X
LAW					
Legal Assisting (Paralegal)		X		X	
LIBERAL STUDIES - MULTIPLE SUBJECT TEACHER PREP		X			
MANAGEMENT		X			
Retail Management				X	
MATHEMATICS	X	X			

DISCIPLINES	ADT	AA	AS	Cert Achieve	Cert Accompl
MULTIMEDIA STUDIES					
Animation & 3D Design		X		X	X
Graphic & Web Design		X		X	X
Video Production		X		X	X
NURSING					
Nursing Assistant and Home Health Aide					X
PHILOSOPHY	X				
PHYSICAL SCIENCE		X			
POLITICAL SCIENCE	X				
PSYCHOLOGY	X	X			
SOCIOLOGY	X				
SPANISH	X	X			

PETITION FOR GRADUATION (to receive an AA/AS Degree):

- Schedule an appointment with a counselor each semester to check progress toward your degree.
- If applicable, have an official copy of all transcripts (including those from College Board for AP exams) from other institutions SENT directly to the Admissions Office (by the institution via US Mail ONLY) reflecting grades of all coursework completed.
- Schedule an appointment with your counselor during your final semester to verify that all degree requirements have been met and complete a Graduation Petition (deadlines for graduation petitions are posted each term).
- Submit your petition with all supporting documents to the Admissions Office.

Continuing students with uninterrupted attendance and demonstrating satisfactory progress, exclusive of Summer and Winter sessions, should refer to the graduation requirements listed in the catalog in effect at the time of their initial enrollment. A continuing student is one who has completed a minimum of one course per calendar year; completion with a "W" will be accepted. Students with interrupted attendance become subject to any new requirements that are in effect at the time of re-enrollment.

Please consult with a counselor to keep informed of the latest changes in graduation and transfer requirements.

NOTE: Completion of the General Education and Major Requirements for an Associate Degree do NOT make the student eligible to transfer to a four-year college or university. Consult the college catalog, your counselor and ASSIST (www.assist.org) regarding transfer requirements

Transfer Information

Transfer Center

818.364.7827 | www.lamission.edu/transfercenter

The Transfer Center helps students prepare to continue their education at a four-year college or university. Counselors and the Transfer Center Staff are your link to transfer to UC, CSU and private institutions. Consult with a counselor regarding general education course requirements needed to transfer. The counselor will help you develop an educational plan to facilitate the process. Transfer center staff will help establish specific goals and objectives.

Transfer Center resources include online/traditional application filing, opportunities to meet with representatives from four-year institutions, a resource library, workshops on transfer issues and information regarding articulation agreements. Students are encouraged to begin planning for transfer as early as possible. Transfer students can earn an Associate Degree while completing transfer requirements.

Essential information for transfer students can be accessed via the following websites:

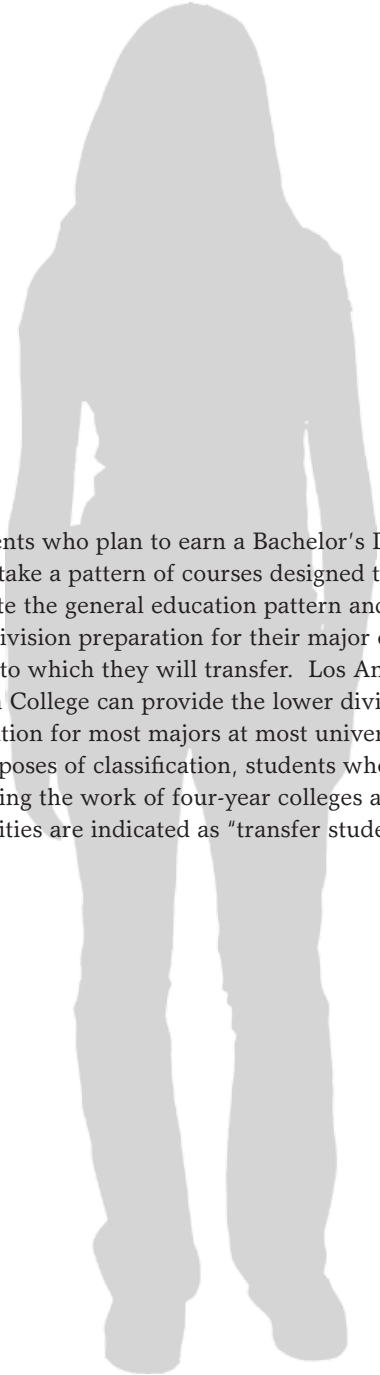

Students who plan to earn a Bachelor's Degree should take a pattern of courses designed to complete the general education pattern and the lower division preparation for their major of the college to which they will transfer. Los Angeles Mission College can provide the lower division preparation for most majors at most universities. For purposes of classification, students who are paralleling the work of four-year colleges and universities are indicated as "transfer students."

Articulation Agreements: www.assist.org

ASSIST (Articulation System Stimulating Interinstitutional Student Transfer) is a computerized information system. It provides students with detailed course transfer and articulation information to help them plan their academic careers. The system facilitates a seamless transfer process, and reduces the number of redundant courses a student may take as they transition from the community college to the university. ASSIST is available for free to all students, faculty and staff via the Internet. It is the official statewide source for course articulation information and includes:

- Articulation agreements between the California Community Colleges and UC or CSU
- List of UC and CSU transferable courses
- List of IGETC approved courses for the advising form
- List of CSU GE approved courses for the advising form

CSU: www.csumentor.edu

CSU Mentor is a free online resource designed to help students learn about the CSU system. Students will be able to select a CSU campus, apply for admission and plan how to finance their higher education. The student will only pay the application fee charged directly by the CSU campus when an application for admission is submitted. Personal data entered by the user is not released without the user's express consent and direction.

UC: www.ucop.edu

University of California Pathways is a free online resource designed to help students learn about the UC system. Students will be able to use one online application to apply to various UC campuses. The student will only pay the application fee for each university when an application for admission is submitted. UC Pathways provides Answers for Transfers, Financial Aid Information, Campus Publications, Directories and links to all UC campus web pages. Personal data entered by the user is not released without the user's express consent and direction.

With careful planning, a student can complete the requirements for the Associate Degree while simultaneously completing the lower division preparation for most universities. Three requirements must be met in order to attain full junior standing at the UCs, the CSUs, or most independent universities to which students expect to transfer. These requirements are as follows:

1. Completion of 60 transferable units (units may vary at independent universities)
2. Completion of the specific General Education Requirements for junior standing in the proposed college or university
3. Completion of the lower division prerequisites for selected majors. These vary according to the institution in which students expect to enroll.

NOTE: Students expecting to transfer to such institutions should contact the Los Angeles Mission College Transfer Center to see a counselor and consult the respective catalog of these institutions regarding specific requirements for upper division standing.

INTERSEGMENTAL GENERAL EDUCATION TRANSFER CURRICULUM (IGETC) (IGET EMC /Span/MCID 10 BDCr C)

Disclaimer: Every effort has been made to ensure the information below is accurate and timely. However, this information is unofficial and should be checked against the official information found on the ASSIST website @ www.assist.org. At the time of publication, the 2015-2016 IGETC was available. Please check the Assist website in late Spring 2016 for the updated 2016-2017 IGETC and see a counselor for help in planning your coursework.

A minimum "C" grade is required in each course. A "C" is defined as a minimum 2.0 grade points on a 4.0 scale.

What is the Intersegmental General Education Transfer Curriculum?

The Intersegmental General Education Transfer Curriculum (IGETC) is a general education program which community college transfer students can use to fulfill lower-division General Education Requirements in either the UC or CSU system without the need to take additional lower-division general education courses after transfer.

The IGETC is NOT an admission requirement to the UC or CSU system. There is no connection between completion of the IGETC and eligibility for admission to the UC or CSU system, or admission to a specific campus or program. Existing segmental and campus-specific admission requirements for transfer students remain unchanged. Requirements for lower division courses for admission to particular majors also remain unchanged.

A minimum total of 60 transferable units must be completed before transfer, for priority admission status. It is recommended that students complete lower division (the first two years of a four-year college) major requirements and general education requirements for the UC and/or CSU prior to transfer.

It is NOT advisable for all students to follow the IGETC. Some students may be better served by taking courses that fulfill the CSU General Education Breadth requirements or those of the UC campus or college to which they plan to transfer. Students pursuing majors that require extensive lower division major preparation, (such as engineering and computer science majors on all campuses or business majors at University of California, Berkeley) may not find the IGETC option to be advantageous. The Eleanor Roosevelt College and Revelle College of the University of California, San Diego do not accept IGETC. Additional lower division General Education Requirements may be needed prior to transfer. The IGETC will probably be most useful for students who want to keep their options open before making a final decision about transferring to a particular UC or CSU campus.

If you are approaching readiness for transfer and are unable to complete one or two IGETC courses you may be eligible for Certification. "Certification" means that LAMC has verified that a student has completed the lower division General Education requirements listed in each area of the IGETC. Certification does not guarantee admission or admission eligibility. Certification is not required

Transfer Information

and is not automatic; it must be requested by the student at the time the final official transcript is sent. A student may only be granted IGET EMC /Span /MCID 6 once (either partial or complete) prior to their first semester at the 4-year university. Students receiving partial certification must ensure that admission criteria for the university has been met (IGETC areas I and II). Students may complete the necessary coursework at the transfer institution and may NOT return to the Community College for complete certification if partial certification was granted. Without certification, the student will be held to the specific general education requirements of the university campus of choice. Please note, the UC Berkeley, College of Letters and Science does not accept partial Certification. Courses taken at several institutions may be used to fulfill the IGETC. Students should be aware, however, that placement of courses within IGETC subject areas may vary from college to college. Placement of a course will be based on the college of attendance and its IGETC pattern at the time the course was completed. Completion of the IGETC program will be certified by the last community college which the student attends.

CALIFORNIA STATE UNIVERSITIES Transfer Requirements

Disclaimer: Every effort has been made to ensure the information below is accurate and timely. However, this information is unofficial and should be checked against the official information found on the ASSIST website @ www.assist.org. At the time of publication, the 2015-2016 CSU-GE was available. Please check the Assist website in late Spring 2016 for the updated 2016-2017 CSU-GE and see a counselor for help in planning your coursework.

It is recommended that students complete lower division (the first two years of a four-year college) major requirements and general education requirements of the California State University before transferring. Note that some California State Universities and some departments may require more than a "C" average for admission.

Requirements for the Associate in Arts for Transfer (AA-T) or Associate in Science for Transfer (AS-T)

The Student Transfer Achievement Reform Act (Senate Bill 1440, now codified in California Education Code sections 66746-66749) guarantees admission to a California State University (CSU) campus for any community college student who completes an "associate degree for transfer", a newly established variation of the associate degrees traditionally offered at a California community college. The Associate in Arts for Transfer (AA-T) or the Associate in Science for Transfer (AS-T) is intended for students who plan to complete a bachelor's degree in a similar major at a CSU campus. Students completing these degrees (AA-T or AS-T) are guaranteed admission to the CSU system, but not to a particular campus or major. In order to earn one of these degrees, students must complete a minimum of 60 required semester units of CSU-transferable coursework with a minimum GPA of 2.00. Students transferring to a CSU campus that does accept the AA-T or AS-T will be required to complete no more than 60 units after transfer to earn a bachelor's degree (unless the major is a designated "high-unit" major). This degree may not be the best option for students intending to transfer to a particular CSU campus or to university or college that is not part of the CSU system. Students should

Transfer Information

consult with a counselor when planning to complete the degree for more information on university admission and transfer requirements. At the time of publication, no majors for the AA-T or AS-T have been approved. Majors are under development and pending approval from the State of California. For more information, please see a counselor for more information.

Requirements:

The following is required for all AA-T or AS-T degrees:

1. Minimum of 60 CSU-transferable semester units
2. Minimum grade point average (GPA) of at least 2.00 in all CSU-transferable coursework. While a minimum of 2.00 is required for admission, some majors may require a higher GPA. Please consult with a counselor for more information.
3. Completion of a minimum of 18 semester units in an AA-T or AS-T major. All courses in the major must be completed with a grade of C or better or a "P" if the course is taken on a "pass-no pass" basis (title 5 section 55063)
4. Certified completion of the California State University General Education-Breadth pattern (CSU GE Breadth) (see page 81); OR the Intersegmental General Education Transfer Curriculum (IGET EMC /Span /MCID 11 BDC C) pattern (see page 80)

What is the CSU-GE (CSU General Education)?

Los Angeles Mission College has an agreement with the California State University System through which students at LAMC can complete all lower division General Education Requirements for any of the 23 CSU campuses. If the 39 unit pattern described is completed, Los Angeles Mission College will certify to the California State University System that all lower division General Education Requirements have been met. Students can receive partial certification in one of the categories A through E after completing the requirements for that category. However, a minimum of 12 units from the certification requirements must be completed for partial certification. CSU GE Breadth Certification may be certified by the last community college the student attends.

Students must petition for full or partial certification by seeing an LAMC counselor. With careful preparation, it is possible for a student to complete the AA General Education Requirements for Los Angeles Mission College while completing these certification requirements. Some courses appear in several areas, but one course may NOT be used to meet more than one General Education Requirement.

INDEPENDENT CALIFORNIA COLLEGES & UNIVERSITIES

California's fully accredited independent colleges and universities provide a host of options at undergraduate, graduate, and professional levels for students planning to continue their education beyond community college. Students who transfer to independent colleges or universities find they are given academic credit for most, if not all, of their community college studies. Virtually all institutions give full credit for general education courses and usually other courses designated for transfer by the community college.

Some colleges and universities stipulate a certain number of completed units before considering students eligible for transfer. Others do not and will accept students at any time. The requirements are outlined in the respective college catalogs, available for viewing at the Transfer Center.

Independent institutions are generous in awarding credit. They invite students to make an appointment with their Office of Admissions in order to discuss transfer opportunities on a personal basis.

2016-2017 INTERSEGMENTAL GENERAL EDUCATION TRANSFER CURRICULUM (IGETC)

Disclaimer: Every effort has been made to ensure the information below is accurate and timely. However, this information is unofficial and should be checked against the official information found on the ASSIST website @ www.assist.org. A minimum "C" grade is required in each course. A "C" is defined as a minimum 2.0 grade points on a 4.0 scale.

1. English Communications

CSU: 3 courses required, one from each Area 1A, 1B, 1C

UC: 2 courses required, one from each Area 1A and 1B

1A. ENGLISH COMPOSITION

English 101

1B. CRITICAL THINKING/ENGLISH COMPOSITION

English 102, 103

Philosophy 5

1C. ORAL COMMUNICATION (CSU ONLY)

Communication Studies 101, 102, 151

2. Mathematical Concepts & Quantitative Reasoning

1 course (3 semester/4 quarter units)

Mathematics 227, 238, 245, 260, 265, 266, 267, 270, 272, 275

3. Arts & Humanities

3 courses (9 semester/12 quarter units)

Choose one course from A, one course from B, and a third course from A or B.

3A. ART

Art 101, 102, 103, 105, 109, 111, 201, 300, 501, 502

Art History 161

Chicano Studies 52, 58

Cinema 3

Dance Studies 805

Humanities 1, 3

Music 111, 141

Theater 100, 114

3B. HUMANITIES

Anthropology 104

Art History 161

Chicano Studies 37, 42, 44, 46

Cinema 4

English 203, 205, 206, 208, 240

Humanities 1, 2, 3, 30, 31

Linguistics 1

Philosophy 1, 14, 20, 33

Spanish 3, 4, 5, 6

4. Social & Behavioral Sciences

(9 semester/12 quarter units)

Choose three courses from at least two different disciplines:

Administration of Justice 1, 4

African American Studies 2, 4

Anthropology 102, 104, 121

Child Development 1

Chicano Studies 2, 7, 8, 19, 20, 44, 47

Economics 1, 2, 10

Geography 2, 7, 14

History 1, 2, 11, 12, 86

Journalism 100

Linguistics 1

Political Science 1, 2, 5, 7

Psychology 1, 2, 13, 14, 41, 52

Sociology 1, 2, 3, 11, 24, 28, 31

5. Physical & Biological Sciences

(7 semester/9 quarter units)

At least 2 courses, with one from the Physical Science and one from the Biological Science, at least one of the two courses must include a corresponding lab course:

see Area 5C

5A. PHYSICAL SCIENCE

Astronomy 1, 5

Chemistry 51, 52, 65, 101, 102, 211, 212

Earth Science 1

Geography 1, 15

Geology 1

Oceanography 1

Physical Science 1, 14

Physics 6, 7, 37, 38, 39

5B. BIOLOGICAL SCIENCES

Anatomy 1

Anthropology 101

Biology 3, 5, 6, 7, 40

Environmental Science 2

Microbiology 20

Physiology 1

Psychology 2

5C. LABORATORY SCIENCE REQUIREMENT

Anatomy 1

Astronomy 5

Biology 3, 5, 6, 7, 40

Chemistry 51, 52, 65, 101, 102, 211, 212

Earth Science 2

Geography 15

Microbiology 20

Physical Science 14

Physics 6, 7, 37, 38, 39

Physiology 1

6. Language Other Than English (UC Requirement ONLY)

Proficiency equivalent to two years of high school study in the same language:

French 2 or higher

Italian 2 or higher

Portuguese 2 or higher

Spanish 2 or higher

If a language level 3 or higher is used to satisfy this requirement, it may also be used in Area 3B.

High School: 2 year of the same foreign language with a "C-" or better GPA in the final second-year course.

CSU Requirement only

Not part of IGETC, but may be completed prior to transfer.

For IGETC Certification purposes, courses used to satisfy this CSU graduation requirement may also be used to satisfy IGETC area 3 and/or 4. If a course is used to satisfy both an IGETC subject area and this CSU graduation requirement, some CSU campuses may require students to take an additional course(s) after transfer.

US 1. African American Studies 4, Chicano Studies 8, Economics 10, History 11, 12

US 2. Political Science 1

US 3. Political Science 1

2016–2017 CALIFORNIA STATE UNIVERSITY SYSTEM – GENERAL EDUCATION PLAN

Disclaimer: Every effort has been made to ensure the information below is accurate and timely. However, this information is unofficial and should be checked against the official information found on the ASSIST website @ www.assist.org.

A. English Language Communication & Critical Thinking

9 semester/12 quarter units
Select one course from each area below.

A-1 Oral Communication:
minimum grade of C required
Comm 101, 102, 151

A-2 Written Communication:
minimum grade of C required
English 101

A-3 Critical Thinking:
minimum grade of C required
Comm 102
English 102, 103
Philos 5, 6, 9

EFFECTIVE FALL 2016:

CSUGE Areas **A1**, **A2**, **A3**, and **B4** must be completed with a grade of "C" or higher.

B. Scientific Inquiry & Quantitative Reasoning

9 semester/12 quarter units
At least one course from Physical Science, Life Science, and Mathematics/Quantitative Reasoning. At least one of the science courses must contain a laboratory component that corresponds to the lecture course used. See Area B-3 below.

B-1 PHYSICAL SCIENCE

Astron 1, 5
Chem 51, 52, 65, 101, 102, 211, 212
Earth Sci 1
Geog 1, 15
Geology 1
Ocean 1
PhysSci 1, 14
Physics 6, 7, 38, 39

B-2 LIFE SCIENCES

Anatomy 1
Anthro 101
Biology 3, 5, 6, 7, 40
EnvSci 2
Micro 20
Physiol 1
Psych 2

B-3 LABORATORY ACTIVITY

Anatomy 1
Astron 5
Biology 3, 5, 6, 7, 40
Chem 51, 52, 65, 101, 102, 211, 212
Earth Sci 2
Geog 15
Micro 20
PhysSci 14
Physics 6, 7, 37, 38, 39
Physiol 1

B-4 MATHEMATICS/QUANTITATIVE REASONING:

minimum grade of C required
Math 215, 227, 238, 240, 245, 260, 265, 266, 267, 270, 272, 275

C. Arts & Humanities

9 semester/12 quarter units
Select one course from C-1, one from C-2, and a third from C-1 or C-2.

C-1 ARTS

Art 101, 102, 103, 105, 109, 111, 201, 300, 501, 502
Art Hist 161
Chicano 52, 58
Cinema 3
DanceStd 805
English 240
Human 1, 3, 31
Intrdsgn 104
Music 101, 111, 141, 321, 322, 323, 324, 341
Photo 10, 11, 12
Theater 100, 114

C-2 HUMANITIES

Anthro 104
Art Hist 161
Chicano 37, 42, 44, 46, 58
Cinema 4
English 127, 203, 205, 206, 208, 240
French 1, 2
History 86
Human 1, 2, 30, 31
Italian 1, 2
Ling 1
Philos 1, 14, 20, 33
Portgse 1, 2
Spanish 1, 2, 3, 4, 5, 6

D. Social Sciences

9 semester/12 quarter units
Courses must be chosen from at least two disciplines.

The American Institutions requirement may be completed as part of the 9 units required in Area D.

AMERICAN HISTORY AND INSTITUTIONS REQUIREMENT

May be met by completing Political Science 1 AND one of the following courses:

AfroAm 4, Chicano 8, Econ 10; History 11, 12.

It is highly recommended students complete these requirements, as it will meet the CSU graduation requirement.

AdmJus 1, 4
AfroAm 2, 4
Anthro 102, 104, 121
Bus 5
ChDeev 1, 42
Chicano 2, 7, 8, 19, 20, 44, 47, 71
Comm 121
Econ 1, 2, 10
Geog 2, 7, 14
History 1, 2, 11, 12, 86
Journ 100
Law 1
Ling 1
Math 272
PolSci 1, 2, 5, 7
Psy 1, 2, 13, 14, 41, 52
Soc 1, 2, 3, 7, 11, 24, 28, 31

E. Lifelong Understanding & Self Development

3 semester/4 quarter units, not all in 1-unit Kinesiology/Dance Activity courses

Chicano 47
ChDev 1
DanceTec 121, 141, 142, 462
EnvSci 2
Fam&CS 6, 21, 31, 91
Health 8, 11
Kin Athlt 503, 511, 512, 516, 552, 557, 558, 563, 564
Kin Maj 100
Kin 35-552
Psy 1, 2, 41, 52

Transfer Information

ASSOCIATE DEGREE FOR TRANSFER

California Community College students interested in transfer to a California State University (CSU) are encouraged to learn more about the Associate in Arts or Associate in Science for Transfer (AA-T or AS-T) Degrees. These Transfer Degrees are designed to provide a clear pathway for transfer. California Community College students awarded an AA-T or AS-T degree are guaranteed admission with junior standing in a program that is deemed "similar" within the CSU system. Although priority admission consideration is given to the student's local CSU campus within a "similar" program, it does not guarantee admission to a specific major or campus.

Students who have been awarded an AA-T or AS-T are able to complete the remaining requirements for the 120-unit baccalaureate degree within 60 semester or 90 quarter units.

Los Angeles Mission College offers several Associate Degrees for Transfer and to find out which CSU campuses accept each degree, go to www.sb1440.org. Students are encouraged to meet with a counselor to review their options for transfer and to develop an educational plan that best meets their goals and needs.



At the time of catalog publication, a student may earn an AA-T or AS-T at LAMC in the following majors:

- AS-T Administration of Justice (page 85)
- AS-T Biology (page 94)
- AS-T Business Administration (page 95)
- AA-T Communication Studies (page 107)
- AS-T Early Childhood Education (page 104)
- AA-T Elementary Teacher Education (page 125)
- AA-T English (page 127)
- AS-T Mathematics (page 153)
- AA-T Philosophy (page 162)
- AA-T Political Science (page 165)
- AA-T Psychology (page 166)
- AA-T Sociology (page 168)
- AA-T Spanish (page 169)
- AA-T Studio Art (page 89)

Requirements

The following is required for all AA-T or AS-T degrees:

1. Minimum 60 CSU-transferable semester units.
2. Minimum grade point average (GPA) of 2.0 in all CSU-transferable coursework. Although a 2.0 GPA is required for admission, some majors may require a higher, more competitive GPA. Please consult the counselor, the ASSIST website (www.assist.org) and the college catalog for more information.
3. Completion of a minimum of 18 semester units in an "AA-T" or "AS-T" major as detailed in the Disciplines section of this catalog. All courses in the major must be completed with a grade of "C" (2.0) or better. Local graduation requirements are not needed for degree to be granted.
4. Certified completion of the California State University, General Education-Breadth (CSU GE Breadth) pattern (see page 81), OR the Intersegmental General Education Transfer Curriculum (IGETC) pattern (see page 80).
5. Complete a minimum of 12 units at LAMC.

THREE (3) REPEAT RULE

Effective summer 2012, course withdrawal ("W") or a substandard grade ("D," "F," or "NP") count as an attempt at a course. Only three attempts at any one course will be allowed, with some exceptions. Listed below are the new rules that all students need to know about.

- Students who drop or are excluded after the last day to drop without a grade of "W" will have a "W" appear on their transcript. The "W" will count as an attempt for that course.
- Deadlines to drop classes without a "W" are posted on the schedule of classes, available on the college website.
- A course in a student's transcript which currently shows a recorded "W" counts as an attempt for that course.
- Students will not be allowed to register for any course within the LACCD if there are three recorded attempts for that course in any combination of W, D, F, or NP grades.
- Add permits for a course within the LACCD will not be processed if there are three recorded attempts for that course in any combination of W, D, F, or NP grades.
- For courses specifically designated as "repeatable," students may repeat up to three times. (See Title 5 California Code of Regulations sections 55040, 55041, 58161)
- Where the student's number of enrollments in a course exceeds the allowable amount, the student may petition for an additional enrollment in cases of extenuating circumstances.

What students should do:

- Be sure you are academically ready for classes you enroll in.
- If you must drop a course, drop before the specified deadline for dropping a class without a grade of "W."



Disciplines

Educational Programs & Course Descriptions

The following pages provide a listing of Los Angeles Mission College's educational disciplines, faculty, educational programs, and course descriptions.

Discipline - A discipline is a field of study, and the permanent faculty that instruct in that field of study are provided.

Educational Programs - The educational programs offered at Los Angeles Mission College are varied.

Associate Degree - A degree (Associate in Arts, AA, or Associate in Science, AS) granted which recognizes a student's satisfactory completion of an organized program of study consisting of a minimum of 60 degree-applicable semester units.

Certificate of Achievement - A program designed for students who are looking for instruction with a high degree of specialization. Certificate programs vary in length, but must have 18 or more semester units, and may be pursued on a full-time or part-time basis. Upon completion, students may request the issuance of a Certificate of Achievement.

Certificate of Accomplishment - A program designed for those students who have limited time or who want to limit their commitment to a particular field of study. Students may be seeking increased specialization that is job-related, advancement in their present jobs, or preparation for new employment. Certificates of Accomplishment are limited to 17 or fewer semester units. The courses that make up the Certificate of Accomplishment often apply toward the Certificate Program and Associate Degree. Always consult a counselor for verification.

Course Descriptions - Also found in the following pages are descriptions of the courses offered in the various disciplines at Los Angeles Mission College. The title of the course is shown on the first line.

In addition, the following code letters will be found before the number of units:

UC - This course is acceptable for credit by all University of California campuses. UC has a limit on the number of units allowable for transfer. Please check with an LAMC counselor and the appropriate UC catalog for information. Also acceptable at CSU.

CSU - This course is acceptable for credit by all California State Universities. CSU has a limit on the number of units allowable for transfer. Please check with an LAMC counselor and the appropriate CSU catalog for information.

NDA - AB 1725 establishes a new category called Non-Degree Applicable. These classes are marked (NDA) in the schedule. Credit for these classes does not apply toward the AA or AS Degree. These classes are not transferable.

RPT - This indicates that the course may be repeated for credit. The number following RPT determines the number of times that the course may be repeated.

Prerequisite - A class or skill that you must have prior to enrolling in the target class. The faculty of that discipline requires the prerequisite because they feel it is necessary for you to succeed in the target course.

Corequisite - A class that must be taken simultaneously with the target course. A corequisite may be completed with passing grade ("C" or better) prior to enrollment in the target course.

Advisory - A class or skill you are advised to have, but not required to have, prior to enrolling in the target course

Disciplines • Educational Programs • Course Descriptions

ACCOUNTING BUSINESS / LAW

FACULTY: Vilma Bernal, Chair | Steven Nerud

EDUCATIONAL PROGRAM

ASSOCIATE IN ARTS - Accounting

For General Education Requirements, see page 73

This degree serves as the basis for further undergraduate education in accounting as well as preparing students for entry-level positions in accounting and tax preparation. It is designed to enable students to do accounting work in the public sector or in private companies. The degree provides a foundation for careers in business-related fields such as Management, Banking, Finance, and Law.

NOTE: A minimum of 60 units and a cumulative GPA of 2.0 or higher must be completed to earn the Associate in Arts Degree. Always consult a counselor for information on graduation requirements, residency requirements and transfer information.

Program Learning Outcomes –

Upon completion, students will be able to:

- Apply accounting concepts and principles to support financial and managerial accounting analyses and problem solving.
- Utilize critical thinking skills, together with ethical values, to evaluate accounting and financial information and formulate business decisions.

REQUIRED COURSES

Acctg 1	Introductory Accounting I	5
Acctg 2	Introductory Accounting II	5
Bus 1	Introduction to Business	3
Bus 5	Business Law I	3
CAOT 32	Business Communications	3
CAOT 78	Microcomputer Accounting Applications for the Electronic Office	3

Select one course:

Acctg 15	Tax Accounting I	3
Bus 10	Fundamentals of Tax Return Preparation	3

Select one course:

Econ 1	Principles of Economics I	3
Econ 2	Principles of Economics II	3

Select two courses:

CAOT 82	Microcomputer Software Survey in the Office	6
CAOT 85	Microsoft Office Applications: Spreadsheet	6
Co Sci 401	Introduction to Computers & their uses	6
Econ 1	Principles of Economics I	3
or Econ 2	Principles of Economics II	3
Finance 1	Principles of Finance	3
Finance 8	Personal Finance & Investments	3

UNITS

Total 34

1 INTRODUCTORY ACCOUNTING I (UC:CSU) 5 UNITS

Prerequisite: None | Lecture 5 hrs

Acctg 21 and Acctg 22 together equal Acctg 1

Provides an introduction to accounting theory and practice using journals, ledgers and worksheets. An overview of the accounting cycle is presented for both service and merchandising businesses. Emphasis is placed on the application of accounting principles in the preparation and analysis of financial statements. The course is designed for students majoring in business disciplines and planning to transfer.

2 INTRODUCTORY ACCOUNTING II (UC:CSU) 5 UNITS

Prerequisite: Acctg 1 | Lecture 5 hrs

A continuation of Accounting 1, the course will emphasize the basic elements of managerial accounting used in decision making. Students will be introduced to manufacturing cost accounting, performance evaluation and investment analysis concepts. The course is designed for students majoring in business disciplines and planning to transfer.

15 TAX ACCOUNTING I (CSU) 3 UNITS

Prerequisite: Acctg I or Acctg 21 and Acctg 22
Lecture 3 hrs

A study of Federal and California State Income Taxes as they apply to individuals and sole proprietorships and an analysis of laws, consideration of appropriate accounting procedures, and preparation of reports and returns.

21 BOOKKEEPING & ACCOUNTING I (UC:CSU) 3 UNITS

Prerequisite: None | Lecture 3 hrs

Acctg 21 and 22 together equal Acctg 1

An introductory course on how to perform double entry bookkeeping, work with special journals, and post entries to the general ledger accounts. In addition, students will learn how to prepare trial balances, work sheets, income statements, balance sheets, and adjusting and closing journal entries.

22 BOOKKEEPING & ACCOUNTING II (UC:CSU) 3 UNITS

Prerequisite: Acctg 21 | Lecture 3 hrs

Acctg 21 and 22 together equal Acctg 1

Review of the fundamentals of bookkeeping and accounting and the preparation of adjusting, closing, and reversing entries, work sheets and financial statements for a sole proprietorship. Application of accounting principles to partnership and corporation accounting records.

25 AUTOMATED ACCOUNTING METHODS & PROCEDURES 3 UNITS

Prerequisite: Acctg 1 or Acctg 21 and Acctg 22

Course is designed for hands-on experience using computer application for accounting. Emphasis will be to learn computerized accounting with special emphasis on sales, receivables, payables, purchases, general accounting, end-of-period procedures, payroll and merchandising.

ADMINISTRATION OF JUSTICE

BUSINESS / LAW

FACULTY: Vilma Bernal, Chair | Kelly Enos, Vice Chair

EDUCATIONAL PROGRAMS

ASSOCIATE IN SCIENCE Administration of Justice

For General Education Requirements, see page 73

Students completing the following program will be awarded an Associate in Science Degree in Administration of Justice.

NOTE: A minimum of 60 units and a cumulative GPA of 2.0 or higher must be completed to earn the Associate in Science Degree. Always consult a counselor for information on graduation requirements, residency requirements and transfer information.

Program Learning Outcomes –

Upon completion, students will be able to:

- Write basic criminal justice reports and research papers using appropriate writing styles;
- Formulate a career plan and an understanding of qualifications and professional expectations to obtain a job in Administration of Justice;
- Apply critical thinking skills and appropriate problem-solving strategies to criminal justice situations;
- Transfer to an undergraduate program at the university level in the field of criminal justice.

REQUIRED COURSES

AdmJus 1	Introduction to Administration of Justice
AdmJus 2	Concepts of Criminal Law
AdmJus 3	Legal Aspects of Evidence
AdmJus 4	Principles & Procedures of the Justice System
AdmJus 5	Criminal Investigation
AdmJus 14	Report Writing for Peace Officers
AdmJus 75	Introduction to Corrections
AdmJus 160	Police Organization & Administration

RECOMMENDED COURSES

AdmJus 104	Introduction to Forensic Science	3
AdmJus 150	Understanding Street & Prison Gangs	3

Associate in Science for Transfer (AS-T) Administration of Justice

Transfer to an undergraduate program at the CSU level within the criminal justice field.

Program Learning Outcomes –

Upon completion, students will be able to:

- Write basic criminal justice reports and research papers using appropriate writing styles;
- Formulate a career plan and an understanding of qualifications and professional expectations to obtain a job in Administration of Justice;
- Apply critical thinking skills and an appropriate problem-solving strategy to a criminal justice situation.

REQUIRED CORE

AdmJus 1	Introduction to Administration of Justice	3
AdmJus 2	Concepts of Criminal Law	3
LIST A: Select two (2) courses		
AdmJus 3	Legal Aspects of Evidence	3
AdmJus 4	Principles & Procedures of the Justice System	3
AdmJus 5	Criminal Investigation	3
AdmJus 8	Juvenile Procedures	3
AdmJus 75	Introduction to Corrections	3
AdmJus 104	Introduction to Forensic Science	3

UNITS	LIST B: Select two (2) courses	3-4
3	Soc 1	Introduction to Sociology
3	Psych 1	General Psychology
3	AdmJus 160	Police Organization & Administration
3	Math 227	Statistics
3	or Any LIST A course not already used	
Total 18–19		

NOTE: A minimum of 60 units and a cumulative GPA of 2.0 or higher must be completed to earn the Associate in Science for Transfer. Always consult a counselor for information on graduation requirements, residency requirements and transfer information.

CERTIFICATE OF ACHIEVEMENT

Students completing the following programs will be awarded a Certificate of Achievement. These Certificates are designed primarily for those students who have a limited amount of time to pursue their career goals and wish to specialize in a particular aspect of the Administration of Justice. They may seek upward mobility in their present job, or they may desire to prepare themselves for a new career.

Probation/Correction Officer Certificate

This program prepares students to work as a probation or corrections officer in a variety of settings including both public and private detention centers, prisons, juvenile correctional facilities and county jails.

Program Learning Outcomes –

Upon completion, students will be able to:

- Enter a career in Corrections, Probation, and/or Parole Departments;
- Formulate a treatment program for juvenile criminal offenders.

REQUIRED COURSES	UNITS	
AdmJus 1	Introduction to Administration of Justice	3
AdmJus 8	Juvenile Procedures	3
AdmJus 39	Probation & Parole	3
AdmJus 75	Introduction to Corrections	3
AdmJus 150	Understanding Street & Prison Gangs	3
AdmJus 385	Directed Studies (Internship)	3

Total 18

Disciplines • Educational Programs • Course Descriptions

CERTIFICATE OF ACCOMPLISHMENT

The student will be given a Certificate of Accomplishment following the completion of the following program if the student has maintained a minimum of a C grade in all required courses. Certificates of Accomplishment are for students who have limited time and wish to limit their commitment but desire an increased level of specialization. Some courses taken in the programs apply toward curriculum leading to an Associate Degree. Always consult a counselor for information on graduation requirements and transfer information.

Basic Police Academy Preparation Certificate of Accomplishment

This skills certificate program is designed for students that are in or anticipating entry into the police academy. This certificate emphasizes courses that most effectively "fast-track" a pre-academy student for entry and successful completion of basic police academy training preparation.

Program Learning Outcomes –

Upon completion, students will be able to:

- Successfully graduate from a police academy;
- Apply laws of arrest, search and seizure, documentation of evidence and patrol procedures in a variety of patrol scenarios and environments.

REQUIRED COURSES

	UNITS
AdmJus 1 Introduction to Administration of Justice	3
AdmJus 2 Concepts of Criminal Law	3
AdmJus 6 Patrol Procedures	3
AdmJus 14 Report Writing for Peace Officers	3
Kin 329 Body Conditioning	1
Total	13

Crime Scene Technology Certificate of Accomplishment

The Crime Scene Technology Certificate program is designed for students preparing for an entry-level career in forensic science or crime scene investigations. Students learn the basic forensic science methods and techniques for field work such as fingerprinting, shoe case impressions, photography and death investigation.

Program Learning Outcomes –

Upon completion, students will be able to:

- Document and record evidence at a crime scene.
- Examine and conduct an analysis of evidence found at a crime scene.

REQUIRED COURSES

	UNITS
Adm Jus 5 Criminal Investigation	3
Adm Jus 104 Introduction to Forensic Science	3
Adm Jus 111 Advanced Forensic Science	3
Adm Jus 204 Homicide and Death Investigation	3
Adm Jus 250 Forensic Photography	4
Total	16

1 INTRODUCTION TO ADMINISTRATION OF JUSTICE (UC:CSU) 3 UNITS

Prerequisite: None | Lecture 3 hrs

The history and philosophy of Administration of Justice in the United States, including identification of the various subsystems such as the police, courts and corrections. Includes the theories of crime, punishment, rehabilitation, ethics, education and training for professionalism in the justice system.

2 CONCEPTS OF CRIMINAL LAW (UC:CSU) 3 UNITS

Prerequisite: None | Lecture 3 hrs

The historical development, philosophy and origins of today's criminal law. The course looks at Definitions and classifications of crimes and their applications to the system of administration of justice.

3 LEGAL ASPECTS OF EVIDENCE (CSU) 3 UNITS

Prerequisite: None | Lecture 3 hrs

A study of the origin, development, philosophy, and constitutional basis of evidence; constitutional and procedural considerations affecting arrest, search, and seizure; kinds and degrees of evidence, and rules governing admissibility; judicial decisions interpreting individual rights and case studies.

4 PRINCIPLES & PROCEDURES OF THE JUSTICE SYSTEM (UC:CSU) 3 UNITS

Prerequisite: None | Lecture 3 hrs

A study of the different aspects of the criminal justice system with an emphasis on the courts. Reviews the different procedures in court settings and how the courts decisions impact society as a whole.

5 CRIMINAL INVESTIGATION (CSU) 3 UNITS

Prerequisites: None | Lecture 3 hrs

Police procedures in criminal investigations and legal aspects and procedures. Students will become familiar with techniques in processing crime scenes, interviewing suspects, witnesses and victims.

6 PATROL PROCEDURES (CSU) 3 UNITS

Prerequisite: None | Lecture 3 hrs

Presents the history and development of patrol philosophy and planning for field activities. The topics include the functions of patrol, traffic, and other preliminary investigative duties of the field officer. The handling of civil and domestic disturbances and other community crime incidents are also discussed.

8 JUVENILE PROCEDURES (CSU) 3 UNITS

Prerequisite: None | Lecture 3 hrs

The organization, function, and jurisdiction of juvenile agencies; the processing and detention of juveniles; juvenile case disposition; juvenile statutes and court procedures.

14 REPORT WRITING FOR PEACE OFFICERS (CSU) 3 UNITS

Advisory: English 21 or ESL 6A | Lecture 3 hrs
The study of effective report writing in police work, including crime scene investigative reports and arrest reports. Students will become familiar with many of the reports and writing styles used by local law enforcement agencies.

39 PROBATION & PAROLE (CSU) 3 UNITS

Prerequisite: None | Lecture 3 hrs
An examination of community treatment in the correctional process, contemporary probation and parole practices, and an exploration of the various community corrections agencies and employment opportunities.

62 FINGERPRINT CLASSIFICATION (CSU) 3 UNITS

Prerequisite: None | Lecture 3 hrs
This is a practical course which covers the technical terminology of fingerprinting, pattern interpretation, and classification of fingerprints, the taking of fingerprints, searching and filing procedures and laboratory work in the classroom.

75 INTRODUCTION TO CORRECTIONS (CSU) 3 UNITS

Prerequisite: None | Lecture 3 hrs
Basic course dealing with the nature of correctional work; aims and objectives of correctional administration; probation and parole; skills, knowledge, and attitudes required for employment in this field; types of institutions and services; career opportunities.

104 INTRODUCTION TO FORENSIC SCIENCE (CSU) 3 UNITS

Prerequisites: None | Lecture 3 hrs
The role of forensic science in Administration of Justice. Several different categories of evidence will be examined including fingerprints, impression evidence, firearms and blood stain pattern analysis.

111 ADVANCED FORENSIC SCIENCE 3 UNITS

Prerequisites: AdmJus 104 | Lecture 3 hrs
Advanced techniques of forensic science and their application in fingerprint evidence, physical anthropology, shooting reconstruction and impression evidence.

150 UNDERSTANDING STREET & PRISON GANGS (CSU) 3 UNITS

Prerequisite: None | Lecture 3 hrs
Provides an introduction to the history and sociology of a gang. Topics include the organization and structure of a street gang, recruitment into a gang, gang attire, hand signs, tattoos, body language, graffiti, and their effect on society. The organizational structure of a prison gang and the relationship with organized crime are also covered.

160 POLICE ORGANIZATION & ADMINISTRATION (CSU) 3 UNITS

Prerequisite: None | Lecture 3 hrs
Historical and modern policing approaches; effect of organizational structure and administrative procedure on the police function; assessment of decision-making processes, police-community relations, and misconduct.

204 HOMICIDE INVESTIGATION 3 UNITS

Prerequisite: None | Lecture 3 hrs
Provides an overview of the investigative techniques and resources that are utilized when investigating a homicide or death, including forensics and criminal profiling.

250 FORENSIC PHOTOGRAPHY (CSU) 4 UNITS

Prerequisite: None | Lecture 4 hrs
Provides the basics of forensic investigation. Course will demonstrate the maintenance of both physical evidence and a photographic record of a crime scene, including a chronological sequence of written and photographic evidence.

185 DIRECTED STUDY (CSU) 1 UNIT

Provides opportunity for in-depth study of a chosen area of Administration of Justice on a contract basis, under the direction of a supervising instructor.

285 DIRECTED STUDY (CSU) 2 UNITS

Provides opportunity for in-depth study of a chosen area of Administration of Justice on a contract basis, under the direction of a supervising instructor.

385 DIRECTED STUDY (CSU) 3 UNITS

Provides opportunity for in-depth study of a chosen area of Administration of Justice on a contract basis,

AFRICAN-AMERICAN STUDIES *SOCIAL SCIENCES*

FACULTY: Mark Pursley, Chair
D'Art Phares, Vice Chair

AMERICAN HISTORY INSTITUTIONS TRANSFER REQUIREMENT

If you took a U.S. history course outside of California, make certain you meet the California State and local government transfer requirements to the California State Universities as listed below. Please consult with a counselor or a history instructor.

- U.S.-1 History – History 11, 12, AfroAm 4, Chicano 8, Econ 10
- U.S.-2 Constitution – PolSci 1
- U.S.-3 State and local government – PolSci 1

2 THE AFRICAN-AMERICAN IN CONTEMPORARY SOCIETY (UC:CSU) 3 UNITS

Prerequisite: None | Lecture 3 hrs
Surveys the urbanization of African-Americans with emphasis on social and political contemporary problems, proposed solutions to civil rights, and equality of opportunity.

4 THE AFRICAN-AMERICAN IN THE HISTORY OF THE UNITED STATES I (UC:CSU) 3 UNITS

Prerequisite: None | Lecture 3 hrs
A survey of U.S. history from the Colonial Era (c. 1600) through the Reconstruction Era (1865-1877) with emphasis on Trans-Atlantic migration. Course provides critical analysis of African-American contributions to the political and social development of the United States.

Disciplines • Educational Programs • Course Descriptions

ALLIED HEALTH LIFE SCIENCES

FACULTY: J. Michael Reynolds, Chair
Dr. Par Mohammadian, Vice-Chair

21 BASIC LIFE SUPPORT 0.5 UNIT RPT 3 **FOR THE HEALTHCARE PROVIDER**

Prerequisite: None | Lecture 0.5 hr

NOTE: Class graded pass/no-pass

Allied Health 21 is designed to teach CPR to healthcare providers and interested students. This course covers infant, child, and both one-rescuer and two-rescuer adult CPR. Treatment of choking the patient and heart disease prevention is also included. Successful course completion earns an American Heart Association Basic Cardiovascular Life Support Card for the Healthcare Provider valid for two years.

ANATOMY LIFE SCIENCES

FACULTY: J. Michael Reynolds, Chair
Dr. Par Mohammadian, Vice-Chair

1 INTRODUCTION TO (UC:CSU) 4 UNITS **HUMAN ANATOMY**

Prerequisite: English 28 or ESL 8 and Biology 3 or Biology 5 | Lecture 3 hrs, Lab 3 hrs

Examines cells, tissues, and organs of these human systems: integumentary, skeletal, muscular, nervous, circulatory, respiratory, digestive, urinary, endocrine, lymphatic, and reproductive. Dissection and microscopy used extensively in lab.

ANTHROPOLOGY SOCIAL SCIENCES

FACULTY: Mark Pursley, Chair

101 HUMAN BIOLOGICAL (UC:CSU) 3 UNITS **EVOLUTION**

Prerequisite: English 28 or ESL 8 | Lecture 3 hrs

Examination of the unifying principles of human evolution including: the basic principles of natural selection, the fossil record, the position of humans within the primate order, the features that make Homo sapiens unique.

102 HUMAN WAYS OF LIFE: (UC:CSU) 3 UNITS **CULTURAL ANTHROPOLOGY**

Prerequisite: English 28 or ESL 8 | Lecture 3 hrs

Comparative survey of human culture, including the study of human society, language, religion, political and economic organization, with examples drawn from earlier as well as contemporary preliterate, peasant, and urban societies.

104 HUMAN LANGUAGE (UC:CSU) 3 UNITS **& COMMUNICATION**

Prerequisite: English 28 or ESL 8 | Lecture 3 hrs

Examines basic principles of linguistics: language components, diversity, origins, acquisition and use are explored, with emphasis on communication and sociocultural factors.

121 ANTHROPOLOGY OF (UC:CSU) 3 UNITS **RELIGION, MAGIC & WITCHCRAFT**

Prerequisite: English 28 or ESL 8 | Lecture 3 hrs

Focuses on religious beliefs and practices around the world. Overview of forms of religious belief; variety of gods and supernatural forces; use of myth, ritual, religious ceremony; shamans, priests, and religious specialists.

ART ARTS, MEDIA & PERFORMANCE

FACULTY: Deborah Paulsen, Chair
Barbara Kerwin | Dr. Thomas Folland

EDUCATIONAL PROGRAMS

NOTE: A minimum of 60 units and a cumulative GPA of 2.0 or higher must be completed to earn the Associate in Arts Degree. Always consult a counselor for information on graduation requirements, residency requirements and transfer information.

ASSOCIATE IN ARTS - Art

For General Education Requirements, see page 73

This curriculum is designed to provide an opportunity to complete an undergraduate major in Art.

Program Learning Outcomes -

Upon completion, students will be able to:

- Create works of art and design using problem solving methodologies and intuitive processes;
- Apply the elements and principles of design with competent skill and technique with two and three-dimensional media, including technology;
- Use discipline specific terminology in oral and written communication;
- Demonstrate aesthetic responsiveness by taking a position on and communicating the merits of specific works of art and how those works of art reflect human values within historical, cultural, political, and philosophical contexts.

REQUIRED COURSES	UNITS
Select two (2) from the following four (4) Art History courses:	6
Art 101 Survey of Art History I	
Art 102 Survey of Art History II	
Art 109 History of Arts of Africa, Oceania & Ancient America	
Art 111 History of Contemporary Art	
Art 201 Drawing I	3
Art 202 Drawing II	3
or Art 204 Life Drawing I	
Art 300 Introduction to Painting	3
Art 501 Beginning Two Dimensional Design	3
Art 502 Beginning Three Dimensional Design	3
Multimd 100 Introduction to Multimedia Computer Applications (Photoshop)	3
	Total 24

ASSOCIATE IN ARTS - Art, Gallery and Museum Studies

For General Education Requirements, see page 73
 Art, Gallery and Museum Studies Associate of Arts Degree prepares students to enter the field of gallery and museum work and to transfer to a Bachelor of Arts program in Art, Media Arts, or Museum Studies. The program combines theory with practical application; art, design and media skills with a foundation in art history; and introduction to exhibition design and museum studies.

Program Learning Outcomes -

Upon completion, students will be able to:

- Synthesize knowledge of modern and contemporary art in the selection of artwork for a themed exhibition.
- Demonstrate ability to plan, design and install an exhibition of art.
- Demonstrate ability to document and market an exhibition through various media.
- Demonstrate ability to write a curators statement in relation to a themed exhibition.

REQUIRED COURSES	UNITS
Select two (2) courses:	6
Art 101 Survey of Art History I	
Art 102 Survey of Art History II	
Art 109 History of Arts of Africa, Oceania & Ancient America	
Art 111 History of Contemporary Art	
Complete the following courses	
Art 92 Introduction to Museum Studies	3
Art 501 Beginning Two Dimensional Design	3
Art 502 Beginning Three Dimensional Design	3
Art 519 Exhibition Design	3
Select one course	3
Multimd 100 Introduction to Multimedia Computer Applications (Photoshop)	
Multimd 240 Graphic Design for Multimedia	
Multimd 320 Web Design	
Photo 10 Beginning Photography	
	Total 21

ASSOCIATE IN ARTS - Painting

For General Education Requirements, see page 73
 This curriculum is designed to provide an opportunity to complete an undergraduate major in Painting.

Program Learning Outcomes -

Upon completion, students will be able to:

- Create works of art and design using problem solving methodologies and intuitive processes;
- Apply the elements and principles of design with competent skill and technique with two and three-dimensional media, including technology;
- Use discipline specific terminology in oral and written communication;
- Demonstrate aesthetic responsiveness by taking a position on and communicating the merits of specific works of art and how those works of art reflect human values within historical, cultural, political, and philosophical contexts;
- Apply color theory in a variety of historical styles;
- Develop a personal dialogue in painting, demonstrated by a cohesive group of five original paintings.

REQUIRED COURSES	UNITS
Select two (2) from the following four (4) Art History courses:	6
Art 101 Survey of Art History I	
Art 102 Survey of Art History II	
Art 109 History of Arts of Africa, Oceania & Ancient America	
Art 111 History of Contemporary Art	
Art 201 Drawing I	3
Art 202 Drawing II	3
or Art 204 Life Drawing I	
Art 300 Introduction to Painting	3
Art 304 Acrylic Painting I	3
Art 305 Acrylic Painting II	3
Art 306 Acrylic Painting III	3
Art 501 Beginning Two Dimensional Design	3
Art 502 Beginning Three Dimensional Design	3
Multimd 100 Introduction to Multimedia Computer Applications (Photoshop)	3
	Total 33

Associate in Arts for Transfer (AA-T) Studio Arts

This Transfer Model Curriculum in Studio Arts is intended as preparation for transfer to California State University System as a major in Studio Art. Students should carefully plan their course choices to ensure that they take the lower division courses prerequisite to upper division course in their area of emphasis, such as Painting, Printmaking or Sculpture. This degree is not intended for transfer to the UC or private colleges.

A degree in studio arts provides the foundation and can lead to many careers in art and design such as: artist, illustrator, graphic and web designer, photographer, animator, architect, interior designer, fashion and costume designer, product designer, set and exhibition designer, educator, art therapist, exhibition curator, art critic, art historian, museum preparator, and art conservator/restorer.

Disciplines • Educational Programs • Course Descriptions

Program Learning Outcomes –

Upon completion, students will be able to:

- Create works of art and design using problem solving methodologies and intuitive processes;
- Apply the elements and principles of design with competent skill and technique with two and three dimensional media, including technology;
- Use discipline specific terminology in oral and written communication;
- Demonstrate aesthetic responsiveness by taking a position on and communicating the merits of specific works of art and how those works of art reflect human values within historical, cultural, political, and philosophical contexts.

REQUIRED CORE

	UNITS
Art 102 Survey of Art History II	3
Art 201 Drawing I	3
Art 501 Beginning Two Dimensional Design	3
Art 502 Beginning Three Dimensional Design	3

LIST A: Select one (1) course

Art 101 Survey of Art History I	3
Art 105 History of Asian Art	
Art 109 History of Arts of Africa, Oceania & Ancient America	

LIST B: Select one (1) course from three (3) of the following areas 9

DRAWING	Art 202 Drawing II or Art 204 Life Drawing I
PAINTING	Art 300 Intro to Painting
SCULPTURE	Art 700 Intro to Sculpture or Art 701 Sculpture I
PHOTOGRAPHY	Photo 10 Beginning Photography

Total 24

RECOMMENDED COURSES AS NEEDED FOR TRANSFER, PLEASE CONSULT WITH A COUNSELOR:

Art 203	Drawing III
or Art 205	Life Drawing II
or Art 304	Acrylic Painting I
or Art 520	Design Workshop
or Art 701	Sculpture I
or Multimd 320	Web Design
or Multimd 610	Digital Audio

NOTE: A minimum of 60 units and a cumulative GPA of 2.0 or higher must be completed to earn the Associate in Arts for Transfer. Always consult a counselor for information on graduation requirements, residency requirements and transfer information.

92 INTRO TO MUSEUM STUDIES (CSU) 3 UNITS

Prerequisite: None | Lecture 3 hrs

Provides a broad introduction to the field of museum work. Topics include the history and philosophy of museums; the social, economic, and political trends that shape museums. The collection and care of objects, exhibition design, education programs, research activities, and public relations will be covered.

101 SURVEY OF ART HISTORY I (UC:CSU) 3 UNITS

Advisory: English 101 | Lecture 3 hrs

A survey of Western Art and Architecture from Pre-historic through Medieval periods; students develop perceptual and critical skills by analyzing the evolution and function of art within historical, cultural, and philosophical contexts.

102 SURVEY OF ART HISTORY II (UC:CSU) 3 UNITS

Advisory: English 101 | Lecture 3 hrs

A survey of Western Art and Architecture from the Renaissance through the Twentieth Century: students develop perceptual and critical skills by analyzing the evolution and function of art within historical, cultural, and philosophical contexts.

103 ART APPRECIATION I (UC:CSU) 3 UNITS

Prerequisite: None | Advisory: English 101
Lecture 3 hrs

A general introduction to art that offers a look at works of art through the study of theory, terminology, themes, design principles, media, techniques, with an introduction to the visual arts across time and diverse cultures.

105 HISTORY OF ASIAN ART (CSU) 3 UNITS

Advisory: English 101 | Lecture 3 hrs

Provides a select overview of art and architecture from India, Southeast Asia, China, Korea, and Japan from pre-history to modern times. Examines social, economic, political, religious and philosophical influences on art and architecture, as well as the interchange of cultural influence and artistic expression.

109 THE ARTS OF AFRICA, OCEANIA & ANCIENT AMERICA (UC:CSU) 3 UNITS

Prerequisite: English 28 or ESL 8
Lecture 3 hrs

Provides an overview of art and architecture from Africa, Oceania, and Native North and South America in relation their history, religion, and culture.

111 HISTORY OF CONTEMPORARY ART (UC:CSU) 3 UNITS

Advisory: Eng 101 | Lecture 3 hrs

A history of the major stylistic movements of Contemporary art from 1945 to the present with attention to the historical circumstances of visual culture. While the Euro-American tradition will be the primary focus, art produced by the global community will also be considered with the advent of Globalism in the 1990s.

161 INTRO TO AMERICAN ART (CSU) 3 UNITS

Advisory: Eng 101 | Lecture 3 hrs

An introductory survey of American Art from its pre-Colonial past to the contemporary era with a focus on the social, political, economic, and philosophical conditions that have resulted in a culturally diverse artistic tradition. The contributions and influences of immigrants, Native Americans, Chicano Americans, Latin Americans, and European Americans are studied in relation to historical contexts.

201 DRAWING I (UC:CSU) 3 UNITS

Prerequisite: None | Lecture 2 hrs, Lab 2 hrs
Introduction to principles, elements, and practices of drawing, employing a wide range of subject matter and drawing media. Focus on perceptually based drawing, observational skills, technical abilities, and creative responses to materials and subject matter, including great works of the human imagination.

202 DRAWING II (UC:CSU) 3 UNITS

Prerequisite: Art 201 | Lecture 2 hrs, Lab 2 hrs
Continuation of Drawing I with an introduction to color. Students develop an intermediate ability to observe and render from life using perspective, with emphasis on the human head, hands, feet and anatomy.

203 DRAWING III (UC:CSU) 3 UNITS

Prerequisite: Art 202 | Lecture 2 hrs, Lab 2 hrs
Students create an advanced portfolio of drawings utilizing techniques and media which emphasize individual artistic development.

204 LIFE DRAWING I (UC:CSU) 3 UNITS

Advisory: Art 201 | Lecture 2 hrs, Lab 2 hrs
A beginning course in drawing the figure from life. Drawings with various time limitations are done to explore the relationships of movement, form, and space as they pertain to the human body. Emphasis is placed on proportion, structure and anatomy. This course is recommended for all art majors.

205 LIFE DRAWING II (UC:CSU) 3 UNITS

Prerequisite: Art 204 | Lecture 2 hrs, Lab 2 hrs
An intermediate course in drawing the human figure. Emphasis is on developing extended knowledge of human anatomy and acquiring enhanced skill in rendering its essential structure.

206 LIFE DRAWING III (UC:CSU) 3 UNITS

Prerequisite: Art 205 | Lecture 2 hrs, Lab 2 hrs
An advanced course in drawing the human figure. Emphasis is placed on developing an advanced knowledge of human anatomy and acquiring advanced skill in rendering its essential structure.

209 PERSPECTIVE DRAWING I (CSU) 3 UNITS

Prerequisite: Art 201 | Lecture 2 hrs, Lab 2 hrs
Draw three-dimensional objects in space using measured vanishing point systems along with direct observation and freehand drawing. Explore methods of drawing cast shadows and mirror reflections in perspective.

300 INTRODUCTION TO PAINTING (UC:CSU) 3 UNITS

Prerequisite: None | Lecture 2 hrs, Lab 2 hrs
An introductory course in painting. Lectures and assignments utilize color theory, historical and contemporary styles of painting from great works of the human imagination which will be studied in relation to painting techniques.

304 ACRYLIC PAINTING I (UC:CSU) 3 UNITS

Prerequisite: Art 300 | Lecture 2 hrs, Lab 2 hrs
A continuation and reinforcement of techniques and styles learned in introduction to Painting, with emphasis on exploring personal expression through a series of paintings utilizing a common theme.

305 ACRYLIC PAINTING II (UC:CSU) 3 UNITS

Prerequisite: Art 304 | Lecture 2 hrs, Lab 2 hrs
Exploration of advanced concepts and ideas in Painting. Emphasis is on composition, color, concept and a variety of materials and techniques.

306 ACRYLIC PAINTING III (UC:CSU) 3 UNITS

Prerequisite: Art 305 | Lecture 2 hrs, Lab 2 hrs
Emphasis upon individuality of response to contemporary problems in painting related to representational or nonobjective imagery.

307 OIL PAINTING I (CSU) 3 UNITS

Advisory: Art 201 | Lecture 1 hr, Lab 4 hrs
An overview of basic oil painting techniques and materials. Composition, color, and form are studied through a range of projects in historical context to bring the individual in touch with contemporary ideas in the field of oil painting.

501 BEGINNING TWO DIMENSIONAL DESIGN (UC:CSU) 3 UNITS

Prerequisite: None | Lecture 2 hrs, Lab 2 hrs
Introduction to the concepts, applications, and historical references related to two-dimensional art and composition, including the study of the basic principles and elements of line, shape, texture, value, color and spatial illusion. Development of a visual vocabulary for creative expression through lecture presentations, studio projects, problem solving, and written assignments.

502 BEGINNING THREE DIMENSIONAL DESIGN (UC:CSU) 3 UNITS

Prerequisite: None | Lecture 2 hrs, Lab 2 hrs
Introduction to the concepts, applications, and historical references related to three-dimensional design and spatial composition, including the study of the elements and organizing principles of design as they apply to three-dimensional space and form. Development of a visual vocabulary for creative expression through lecture presentations and use of materials for three-dimensional studio projects.

519 EXHIBITION DESIGN (CSU) 3 UNITS

Prerequisite: None | Lecture 2 hrs, Lab 2 hrs
Provides a practical application of design concepts as they relate to museum and art exhibitions, environments, displays, and installations. Students will gain a working knowledge of commercial and non-profit galleries. Exhibition preparation, installation, funding, gallery visits, and guest lectures will be part of the curriculum.

Disciplines • Educational Programs • Course Descriptions

520 DESIGN WORKSHOP (CSU) 3 UNITS

Prerequisite: Art 501 | Lecture 2 hrs, Lab 2 hrs
Workshop on principles of design. Emphasis is placed on individual research, experimentation, and the development of style. Students will work with a variety of art materials.

700 INTRODUCTION TO SCULPTURE (UC:CSU) 3 UNITS

Prerequisite: Art 502 | Lecture 2 hrs, Lab 2 hrs
Introduction to three-dimensional sculptural principles, techniques, and concepts utilizing a wide range of materials and practices. Various sculpture methods are practiced with attention to creative self-expression and historical context.

701 SCULPTURE I (UC:CSU) 3 UNITS

Prerequisite: Art 502 | Lecture 2 hrs, Lab 2 hrs
Exploration of sculptural principles, techniques and concepts utilizing a wide range of materials and practices. Various sculpture methods are practiced with attention to creative self-expression and historical context. Emphasis is on contemporary materials, cultural identity, and public art.

702 SCULPTURE II (UC:CSU) 3 UNITS

Prerequisite: Art 700 | Lecture 2 hrs, Lab 2 hrs
Exploration of sculptural principles, techniques and concepts. Methods focus on carving, mold making and casting with attention to creative self-expression and historical context.

703 SCULPTURE III (UC:CSU) 3 UNITS

Prerequisite: Art 502 and 701
Lecture 2 hrs, Lab 2 hrs
Explores the appreciation and creation of sculptural forms in contemporary applications. Emphasis is placed on concept, experimentation, and development of style while examining signature style and site-specific installation.

185 DIRECTED STUDY (CSU) 1 UNIT

Prerequisite: None | Lecture 0.5 hr, Lab 1 hr
Provides opportunity for in-depth study of a chosen area of Art on a contract basis, under the direction of a supervising instructor.

ART HISTORY ARTS, MEDIA & PERFORMANCE

FACULTY: Deborah Paulsen, Chair | Dr. Thomas Folland

161 INTRO TO AMERICAN ART (CSU) 3 UNITS

Advisory: Eng 101 | Lecture 3 hrs
An introductory survey of American Art from its pre-Colonial past to the contemporary era with a focus on the social, political, economic, and philosophical conditions that have resulted in a culturally diverse artistic tradition. The contributions and influences of immigrants, Native Americans, Chicano Americans, Latin Americans, and European Americans are studied in relation to historical contexts.

ASTRONOMY PHYSICAL SCIENCES

FACULTY: Said Pazirandeh, Chair
Richard Rains, Vice Chair

1 ELEMENTARY ASTRONOMY (UC:CSU) 3 UNITS

Advisory: English 21 or ESL 6A | Lecture 3 hrs
Surveys the contents and workings of the universe at an introductory level designed to satisfy the general education science requirement, primarily for non-science majors. Emphasizes the physical principles essential to fundamental understanding of astronomy. Discusses historical foundations, the tools of the astronomer, the solar system, stars and stellar evolution, galaxies and deep space, cosmology, and extraterrestrial life.

5 FUNDAMENTALS OF ASTRONOMY LABORATORY (UC:CSU) 1 UNIT

Corequisite: Astronomy 1 | Lab 3 hrs
Includes the use and maintenance of telescopes. Emphasis is on observations of the moon, planets, binary stars, clusters, nebulae and galaxies. In-class explorations include telescope optics, Kepler's Laws, H-R diagram and analysis of scientific data.

BAKING, PROFESSIONAL PROFESSIONAL STUDIES

FACULTY: Louis Eguaras, Chair

200 PRINCIPLES OF BAKING & PATISSERIE I (CSU) 4 UNITS

Corequisite: ClnArt 60 or FSMgmt 50 & 100
Lecture 2 hrs, Lab 6 hrs
(formerly FSMgmt 109)

Covers the production of quick breads, introduction to puff pastry, laminated dough, and cookies with an emphasis placed on mixing methods. The role of leavening agents, starches, chemical reactions of ingredients and the effect on heat and cold on products. Recipe and menu development, including ingredient selection will be discussed.

210 PRINCIPLES OF BAKING & PATISSERIE II (CSU) 4 UNITS

Prerequisite: ProfBkg 200 or FSMgmt 50, 100 & 109 | Lecture 2 hrs, Lab 6 hrs
Advanced baking and patisserie techniques including advanced formulas. Explore advanced fundamentals techniques in baking and patisserie. Examine how a formula works including changes of yields and altering percentages of ingredients in formulas to produce desired results are stressed.

215 RESTAURANT PLATED DESSERTS 4 UNITS

Prerequisite: ProfBkg 210

Lecture 2 hrs, Lab 6 hrs

Introduction to hot, cold, and frozen desserts with concentration on the composition of restaurant style plated desserts. Topics include traditional composed desserts, modern menu fusion, international/ethnic and classical dessert combinations.

BASIC SKILLS

NON-CREDIT

FACULTY: Dennis Solares, Coordinator

2CE BASIC ENGLISH SKILLS NON-CREDIT

Corequisite: None | Lab 4 hrs

Provides reading and writing instruction and practice in an individualized-instruction laboratory. Students meet in flexible groups with the instructor or tutor and work on a flowchart of assignments at their assessed instructional level. Computerized programs may be used for instruction and practice.

23CE COLLEGE AND SCHOLASTIC ASSESSMENT PREPARATION NON-CREDIT

Prerequisite: None | Lecture 4 hrs

Prepares students to be assessed and/or to take standardized or proficiency exams in the content areas of Math and English. This course provides an overview and review of these areas and is not intended to provide in-depth instruction.

25CE BASIC SKILLS IN COMPUTERS NON-CREDIT

Prerequisite: None | Lecture 4 hrs

Computer literacy. Fundamentals of the Internet and Microsoft processing applications: Power Point, Publisher, and Word. Students acquire basic computer literacy skills necessary for the parental support of children's homework, and self-improvement of performance at the place of work. Topics include ethical and careful use of the Internet, email, chat rooms, and search engines.

38CE GED PREPARATION NON-CREDIT

Prerequisite: None | Lecture 4 hrs

Designed to strengthen the student's test taking skills and prepare them for the General Educational Development (GED) exam. Provides instructions that develops the student's ability to take standardized tests in the areas of reading, Social Studies, Math and Science.

BIOLOGY

LIFE SCIENCES

FACULTY: J. Michael Reynolds, Chair
Dr. Stephen Brown, Vice-Chair | Dr. Angela Echeverri
Dr. Diane Livio | Dr. Par Mohammadian

EDUCATIONAL PROGRAM

ASSOCIATE IN SCIENCE - Biology

For General Education Requirements, see page 73

A Biology degree is appropriate for students who want to pursue careers in the life sciences and allied health professions such as medicine, dentistry and pharmacy. In the 21st century, no field of science can compare to the biological sciences in terms major discoveries that directly affect society and individuals. The disciplines are endless and new ones arise annually: genetic engineering, forensics, biochemistry, veterinary medicine, pathology, botany, zoology, marine biology, forestry, microbiology, conservation biology, ecology, environmental studies, and bioinformatics. An Associate of Science Degree in Biology will transfer to most colleges and universities.

NOTE: A minimum of 60 units and a cumulative GPA of 2.0 or higher must be completed to earn the Associate in Science Degree. Always consult a counselor for information on graduation requirements, residency requirements and transfer information.

Program Learning Outcomes -

Upon completion, students will be able to:

- Apply the scientific method by: developing a hypothesis, designing a controlled experiment, collecting data and interpreting the results;
- Make informed decisions regarding ethical concerns related to a contemporary controversial issue in the life and/or biological sciences.

REQUIRED COURSES		UNITS
Biology 6	General Biology I - Molecular & Cellular Biology	5
Biology 7	General Biology II - Organismal, Evolutionary & Ecological Biology	5
Chem 101	General Chemistry I	5
Chem 102	General Chemistry II	5
		Total 20

RECOMMENDED COURSES		
Math 265	Calculus with Analytic Geometry I or higher Physics sequence (dependent on transfer institution and major)	5
Biology 40	The Science of Biotechnology	4
Anatomy 1	Introduction to Human Anatomy	4
Physiol 1	Introduction to Human Physiology	4
Micro 20	General Microbiology	4



Disciplines • Educational Programs • Course Descriptions

ASSOCIATE IN SCIENCE FOR TRANSFER - BIOLOGY

The Associate in Science in Biology for Transfer degree is appropriate for all students who want to pursue a career in the life sciences and allied health professions such as medicine, dentistry and pharmacy. In the 21st century, no field can compare to the biological sciences in terms of major discoveries that directly affect society and individuals. The disciplines are endless and new ones arise annually: genetic engineering, forensics, biochemistry, veterinary medicine, pathology, botany, zoology, marine biology, forestry, microbiology, conservation biology, ecology, environmental studies, and bioinformatics. The Associate in Science in Biology for Transfer is intended for students who plan to complete a bachelor's degree in Biology or a similar major at a CSU campus. Students completing this degree are guaranteed admission to the CSU system, but not to a particular campus or major.

Program Learning Outcomes -

Upon completion, students will be able to:

- Apply the scientific method by developing a hypothesis, designing a controlled experiment, collecting data and interpreting the results.
- Make informed decisions regarding ethical concerns related to contemporary controversial issues in the life and/or biological sciences.

REQUIRED CORE

		UNITS
Biology 6	General Biology I - Molecular and Cellular Biology	5
Biology 7	General Biology II - Organismal, Evolutionary and Ecological Biology	5

LIST A: (Complete ALL Courses)

Chem 101	General Chemistry I	5
Chem 102	General Chemistry II	5
Physics 6	General Physics I	4
Physics 7	General Physics II	4
Math 265	Calculus with Analytic Geometry I	5

Total 33

- 3 INTRODUCTION TO BIOLOGY** (UC:CSU) 4 UNITS
Prerequisite: English 28 or ESL 8
Advisory: Math 115 or 123B
Lecture 3 hrs, Lab 3 hrs

Examines the fundamental principles of biology with laboratories emphasizing hands-on investigations. Topics include an introduction to evolutionary theory, basic biological chemistry, cell function and reproduction, cellular respiration and photosynthesis, classical and contemporary genetics, gene expression and an introduction to animal structure and function. Meets UC/CSU GE requirement of natural science with a lab.

NOTE: A minimum of 60 units and a cumulative G.P.A. of 2.0 or higher must be completed to earn the Associate in Science for Transfer. Always consult a counselor for information on graduation requirements, residency requirements and transfer information.

- 5 INTRODUCTION TO HUMAN BIOLOGY** (UC:CSU) 4 UNITS
Prerequisite: English 28 or ESL 8
Advisory: Math 115 or 123B or 129B
Lecture 3 hrs, Lab 3 hrs

The course includes basic biological principles as they apply to humans. The course will provide a foundation for advanced courses in Human Anatomy, Physiology, and Microbiology. Topics include chemical principles, the cell, heredity, human anatomy and physiology, microbiology, pathology, ecology, and bioethics.

- 6 GENERAL BIOLOGY I - MOLECULAR & CELLULAR BIOLOGY** (UC:CSU) 5 UNITS
Prerequisite: English 28 or ESL 8, and Math 123C or Math 125, and Chemistry 51 or Chemistry 65 or Chemistry 101
Lecture 3 hrs, Lab 6 hrs

Examines the unifying principles of biology through the study of biological molecules, cell structure and function, metabolism, inheritance, molecular genetics, evolu-

tion and population genetics. Together with Biology 7, this is a fundamental course for biology majors.

- 7 GENERAL BIOLOGY II - ORGANISMAL, EVOLUTIONARY & ECOLOGICAL BIOLOGY** (UC:CSU) 5 UNITS

Prerequisite: English 28 or ESL 8, and Math 123C or Math 125

Advisory: Biology 6 | Lecture 3 hrs, Lab 6 hrs

Examines the unifying principles of biology through the study of phylogeny, taxonomy, animal and plant structure/function, population biology and ecology. Together with Biology 6, this is a fundamental course for biology majors.

- 33 MEDICAL TERMINOLOGY** (CSU) 3 UNITS
Prerequisite: None | Lecture 3 hrs

Examines medical vocabulary by examining the meanings of word components: roots, suffixes and verbs. It is ideal for allied health professionals and allied health students. Emphasis is on words used in clinical medicine.

- 40 THE SCIENCE OF BIOTECHNOLOGY** (UC:CSU) 3 UNITS

Prerequisites: Biology 6 and Chemistry 101

Advisory: English 28 or ESL 8

Lecture 2 hrs, Lab 2 hrs

This course provides a comprehensive introduction to the science of biotechnology by providing both theory and hands-on experience with laboratory methods such as DNA fingerprinting, PCR, cloning DNA fragments, and Western Blotting.

- 185 DIRECTED STUDY** (CSU) 1 UNIT

Allows students to pursue directed study in the Life Sciences on a contract basis under the direction of a supervising instructor.

- 285 DIRECTED STUDY** (CSU) 2 UNITS

Allows students to pursue directed study in the Life Sciences on a contract basis under the direction of a supervising instructor.

385 DIRECTED STUDY (CSU) 3 UNITS
 Allows students to pursue directed study in the Life Sciences on a contract basis under the direction of a supervising instructor.

BUSINESS BUSINESS / LAW

FACULTY: Vilma Bernal, Chair

EDUCATIONAL PROGRAM

ASSOCIATE IN ARTS Business Administration

For General Education Requirements, see page 73
 The Business Administration program is designed to give the student a basic understanding of the field of business and business administration and to meet the general requirements for graduation.
 Through the use of electives, it is also designed with sufficient latitude to allow the student to explore fields of his or her choice. This program is designed to meet the needs of 1) employed persons desiring to prepare for supervisory positions, 2) supervisors and other management personnel who wish to gain knowledge which will enable them to perform their duties more effectively or to advance to more responsible positions.

NOTE: A minimum of 60 units and a cumulative GPA of 2.0 or higher must be completed to earn the Associate in Arts Degree. Always consult a counselor for information on graduation requirements, residency requirements and transfer information.

Program Learning Outcomes –

- Upon completion, students will be able to:
- Analyze and apply ethical values and global perspectives while making appropriate decisions related to administration problems.
 - Apply critical thinking skills to formulate viable solutions to management problems by using basic accounting, business, and financial concepts and technology tools.

REQUIRED COURSES		UNITS
Acctg 1	Introductory Accounting I	5
Bus 1	Introduction to Business	3
Bus 5	Business Law I	3
CAOT 32	Business Communications	3
CAOT 82	Microcomputer Software Survey in the Office	3
Market 21	Principles of Marketing	3
Mgmt 2	Organization and Management Theory	3
Select one course:		3
Econ 1	Principles of Economics I	
Econ 2	Principles of Economics II	
Select two courses:		6
Bus 172	Global Business	
Finance 1	Principles of Finance	
Finance 8	Personal Finance and Investments	
Market 22	Green Marketing	
Mgmt 13	Small Business Entrepreneurship	
Mgmt 31	Human Relations for Employees	
Mgmt 33	Personnel Management	
Total		32

Associate in Science for Transfer (AS-T) Business Administration

The Associate in Science in Business Administration for Transfer is a degree that provides a solid lower-division preparation for students who intend to transfer to a California State University (CSU) for a bachelor's degree in Business Administration. This degree is designed to provide a clear pathway to a CSU and guarantee admissions to a CSU. Although, students are guaranteed admissions, it is not to any particular campus or program in the CSU system. Students will be required to meet with a counselor for specific university major preparation at the college of their choice in order to facilitate a seamless transition. This coursework will satisfy the lower division Economics requirements at some of the CSU campuses.

Program Learning Outcomes –

- Upon completion, students will be able to:
- Transfer to an undergraduate program at the university level in the field of business;
 - Apply ethical values, global awareness and technological skills to identify problems and issues making appropriate decisions related to business problems;
 - Apply critical thinking skills to formulate viable solutions to business problems by using basic accounting, business, and financial concepts.

REQUIRED CORE

	UNITS	
Acctg 1	Introductory Accounting I	5
Acctg 2	Introductory Accounting II	5
Econ 1	Principles of Economics I	3
Econ 2	Principles of Economics II	3
Bus 5	Business Law I	3
LIST A: Select one (1) course		4-5
Math 227	Statistics	
Math 238	Calculus for Business & the Social Sciences I	
LIST B: Select two (2) courses		6
CAOT 82	Microcomputer Software Survey in the Office	
Bus 1	Introduction to Business	
or CAOT 32	Business Communications	
or Any LIST A course not already used		
Total		29-30

NOTE: A minimum of 60 units and a cumulative GPA of 2.0 or higher must be completed to earn the Associate in Science for Transfer. Always consult a counselor for information on graduation requirements, residency requirements and transfer information.

1 INTRODUCTION TO BUSINESS (UC:CSU) 3 UNITS

Prerequisite: None | Lecture 3 hrs

A survey in business providing a multidisciplinary examination of how culture, society, economic systems, legal, global, political, financial institutions, and human behavior interact to affect a business organization's policy and practices within the US and global society. Demonstrates how these influences impact the primary areas of business including: organizational structure and design; leadership, human resource management; marketing; technology; entrepreneurship; legal, accounting; financial practices; the stock and securities market; and therefore affect a business' ability to achieve its organizational goals.

Disciplines • Educational Programs • Course Descriptions

5 BUSINESS LAW I (UC:CSU) 3 UNITS

Prerequisite: None | Lecture 3 hrs

Study of the fundamental principles of law as they apply in the business world by examining legal rights and remedies, business torts and crimes, contracts, agency, employment, intellectual property, business structure and negotiable instruments.

6 BUSINESS LAW II (UC:CSU) 3 UNITS

Prerequisite: None | Lecture 3 hrs

Further study of the fundamental principles of law as they apply in the business world. Examines bailment, the rights and liabilities of agents, principles and third parties, partnerships, corporations, stockholders, negotiable instruments and securities.

10 FUNDAMENTALS OF TAX RETURN PREPARATION 3 UNITS

Prerequisite: None | Lecture 3 hrs

Introduces the fundamentals of Federal and California income tax procedures. This class is associated with the Volunteer Income Tax Assistance program (VITA) which allows students to assist in the preparation of actual tax returns for residents in the community.

38 BUSINESS COMPUTATIONS (CSU) 3 UNITS

Prerequisite: None | Lecture 3 hrs

A course designed to cover the fundamentals of mathematics in business. Practical problems in trade and cash discounts, interest, taxes and insurance, accounting and finance, fractions and decimals, banking and payroll, and percentage applications.

172 GLOBAL BUSINESS (CSU) 3 UNITS

Advisory: English 28 or ESL 8 | Lecture 3 hrs

An overview of the key issues and emerging trends of the global business environment, national business environment, international trade and investment, international financial systems, and international business management. The challenges of globalization in business and how to successfully combat them will be explored.

173 EMERGING GREEN TECHNOLOGIES (EGT) (CSU) 3 UNITS

Advisory: English 28 or ESL 8 | Lecture 3 hrs

Examines emerging technologies that modify established means of operating for many industries. Risks and challenges of these new technologies and profitable market strategies will be evaluated. Students will be introduced to breakthroughs in scientific research that will formulate the future of new businesses.

174 LEADERSHIP (CSU) 3 UNITS

Prerequisite: None | Advisory: English 28 or ESL 8

Lecture 3 hrs
Introduces students to the tasks, strategies, and skills of effective leadership. Course activities will move students from theory to the practical processes of leadership, and will focus on the most important skills necessary to succeed in any professional environment—leading people, inspiring commitment, and managing change. Students will explore the latest in leadership theory as well as develop their own leadership style and competencies.

CHEMISTRY PHYSICAL SCIENCES

FACULTY: Said Pazirandeh, Chair

Dr. Mike Fenton, Vice Chair | Dr. Gayane Godjoian

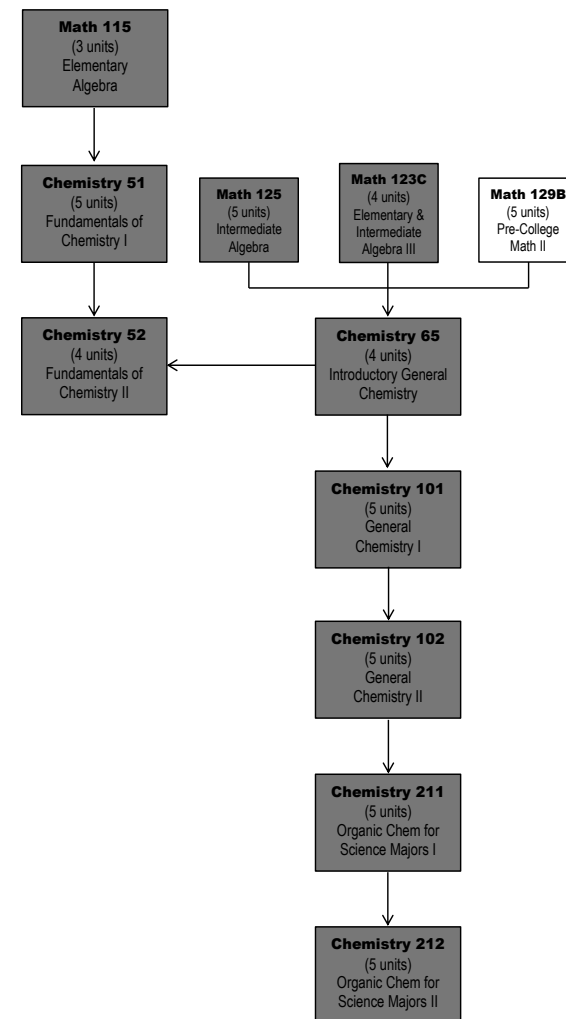

51 FUNDAMENTALS OF CHEMISTRY I (UC:CSU) 5 UNITS

Prerequisite: Math 115 or 123B or 129B

Lecture 3 hrs, Lab 3 hrs

NOTE: It is not intended for students planning to take Chemistry 101.

A course in basic concepts of inorganic chemistry designed for students with interests in nursing, nutrition, dietetics, food science, and environmental and occupational health majors, and for liberal arts students in need of a laboratory course in physical sciences.

52 FUNDAMENTALS OF COLLEGE CHEMISTRY II (UC:CSU) 4 UNITS

Prerequisite: Chem 51 or Chem 65

Lecture 3 hrs, Lab 3 hrs

A continuation of Chemistry 51 required of the Allied Health Science and Environmental and Occupational Health majors. Along with Chemistry 51 satisfies the chemistry course requirement for an Associate in Science - Health Science degree at Los Angeles Mission College.

65 INTRODUCTORY GENERAL CHEMISTRY (UC:CSU) 4 UNITS

Prerequisite: Math 123C or Math 125 or Math 129B | Lecture 3 hrs, Lab 3 hrs

An introductory course for students who wish to enroll in Chemistry 101. Course presents the basic principles, laws, and nomenclature of inorganic chemistry, with emphasis on the application of chemical principles to everyday life and the development of a basic chemical vocabulary.

101 GENERAL CHEMISTRY I (UC:CSU) 5 UNITS

Prerequisites: Chem 65 and Math 123C or Math 125 or Math 129B | Lecture 3 hrs, Lab 6 hrs

A study of fundamental chemical principles and theories, as related to the structure of matter, with special emphasis on stoichiometry, atomic structure, periodic table, chemical bonding, solutions, acids and bases, oxidation-reduction, and properties of gases.

102 GENERAL CHEMISTRY II (UC:CSU) 5 UNITS

Prerequisite: Chem 101

Lecture 3 hrs, Lab 6 hrs

Topics include kinetics, general, ionic, acid-base and solubility equilibria, thermodynamics, electrochemistry, transition metals and introductory organic nomenclature. Laboratory work reviews kinetics, equilibria, thermodynamics, electrochemistry and qualitative analysis of selected cations.

211 ORGANIC CHEMISTRY FOR SCIENCE MAJORS I (UC:CSU) 5 UNITS

Prerequisite: Chem 102

Lecture 3 hrs, Lab 6 hrs

First part of a two-course sequence presenting the structure, equilibrium, nomenclature including conformational analysis, hybridization, stereochemistry and mechanisms of reactions of aliphatic hydrocarbons and related functionalities. The laboratory presents the techniques of preparation, isolation, and analysis of organic compounds employing standard and modern instrumental methods, including Nuclear Magnetic Resonance (NMR) and Infrared (IR) Spectroscopy.

212 ORGANIC CHEMISTRY FOR SCIENCE MAJORS II (UC:CSU) 5 UNITS

Prerequisite: Chem 211

Lecture 3 hrs, Lab 6 hrs

Second part of a two-course sequence presenting reaction mechanisms, stereochemistry, organic synthesis of a variety of organic compounds including but not limited to aromatic compounds, alcohols, phenols, amines, aldehydes, ketones, carboxylic acids and their derivatives, carbohydrates, amino acids, and polypeptides. The laboratory presents techniques preparation, isolation and analysis of organic compounds employing modern instrumental analysis including Nuclear Magnetic Resonance (NMR), Ultraviolet (UV), Infrared (IR), and Mass Spectroscopy.

CHICANO STUDIES

CHICANO STUDIES

FACULTY: John J. Morales Jr., Chair

Jose A. Maldonado, Vice Chair

EDUCATIONAL PROGRAM

The Chicano Studies Associate in Arts program is designed to benefit students interested in careers in business, education, social work and other areas where the focus of services is on the Chicano/a. It is designed to examine the Mexican history and culture rooted within America, as well as indigenous populations in the Americas. Students analyze the social, political, artistic, literary, historical, and cultural contributions of persons of Mexican descent living in the United States.

NOTE: A minimum of 60 units and a cumulative GPA of 2.0 or higher must be completed to earn the Associate in Arts Degree. Always consult a counselor for information on graduation requirements, residency requirements and transfer information.

AMERICAN HISTORY INSTITUTIONS TRANSFER REQUIREMENT

If you took a U.S. history course outside of California, make certain you meet the California State and local government transfer requirements to the California State Universities as listed below. Please consult with a counselor or a history instructor.

U.S.-1 History – History 11, 12, AfroAm 4, Chicano 8, Econ 10

U.S.-2 Constitution – PolSci 1

U.S.-3 State and local government – PolSci 1

Disciplines • Educational Programs • Course Descriptions

ASSOCIATE IN ARTS - Chicano Studies

For General Education Requirements, see page 73

Program Learning Outcomes – Upon completion, students will be able to:

- Analyze the contribution of Mexican descended people to politics, education, society and the arts.
- Compare the experience of Mexican descended people with the other racial, ethnic, and national groups in the U.S. and the world.
- Examine the artistic (literary, visual arts, etc.) contributions of Mexican descended peoples to the world.

REQUIRED COURSES		UNITS
Chicano 2	The Mexican-American in Contemporary Society	3
Chicano 8	The Mexican-American in the History of the US II	3
Chicano 37	Chicano Literature	3
Select three (3) courses:		
Chicano 7	The Mexican-American in the History of the US I	3
Chicano 19	History of Mexico	3
Chicano 20	The Mexican American in California	3
Chicano 42	Contemporary Mexican Literature	3
Chicano 44	Mexican Civilization	3
Chicano 46	Chicano and Mexican Folklore	3
Chicano 47	Mexican-American Woman in Contemporary Society	3
Chicano 52	Mexican Art – Modern	3
Chicano 54	Mexican American Arts in American Culture	3
Chicano 58	Latin American Dance Cultures	3
Chicano 71	The Chicano in Los Angeles	3
		Total 18

2 THE MEXICAN-AMERICAN (UC:CSU) 3 UNITS IN CONTEMPORARY SOCIETY

Prerequisite: None | Lecture 3 hrs

Introduces the student to the most relevant issues facing the Chicano community today. Special attention will be given to the growth and impact of political behavior and under-representation, public health concerns, educational inequities, and immigration policies affecting Mexicans, Chicanos, and other Latinos.

7 THE MEXICAN-AMERICAN IN (UC:CSU) 3 UNITS THE HISTORY OF THE UNITED STATES I

Prerequisite: None | Lecture 3 hrs

A survey of United States history as it relates to the development of the Chicano in the United States with a special emphasis on Mexican-American contributions to the development of American civilization. This course covers Pre-Columbian and Mexican colonial periods, the northward advance and settlement of the present day U.S. Southwest/Southeast. Topics also include a background in the political and social development of both the United States and Mexico, the role and impact of the American Revolution, U.S. Constitution, and the Bill of Rights.

8 THE MEXICAN-AMERICAN IN (UC:CSU) 3 UNITS THE HISTORY OF THE UNITED STATES II

Prerequisite: None | Lecture 3 hrs

Concentrates on Mexican American history of the nineteenth and twentieth centuries. Discussion centers on the participation, contributions, and experiences by Mexican Americans. Major areas include the socio-historical, political, judicial, legislative, economic and educational experiences. Topics include the Mexican American Southwest, the U.S Mexico War, American Expansionism, U.S. Treaties, U.S. Constitution, Bill of Rights, California Constitution, desegregation struggle, American Nativism, Mexican Repatriation, WWII, Zoot-Suit Riots, Bracero Program, Mexican American Labor Movement and the Chicano Movement and their impact on political participation. This course fulfills the American History and Institutions requirements under Social Sciences (Section D), both under U.S. History and Political science components.

19 HISTORY OF MEXICO (UC:CSU) 3 UNITS

Prerequisite: None | Lecture 3 hrs

Course covers the entire span of Mexican history. It includes a consideration of the pre-conquest period, Spanish invasion and colonization, the War of Independence, the turmoil of the nineteenth century, the period of Diaz, the 1910 Revolution, the post-Revolution period, and a view of trends in contemporary Mexico.

- 20 THE MEXICAN AMERICAN IN CALIFORNIA** (UC:CSU) 3 UNITS
Prerequisite: None | Lecture 3 hrs
Survey of the political, economic, social and intellectual history of the Pacific Coast from the Pre-Columbian Era, the Spanish Era, the Mexican years, and lastly, the Anglo presence, with special emphasis on California. A greater emphasis is given to the role of the Chicana/Latino people in the economic, political, social, and cultural development of California from the time of the Spanish Empire to the present.
- 37 CHICANO LITERATURE** (UC:CSU) 3 UNITS
Prerequisite: None | Lecture 3 hrs
Same as Spanish 46 (Not offered at LAMC)
An introductory analysis of the literary, social, and cultural aspects of the novel, short story, essay, poetry, and drama written by Mexican-Americans. The course reveals the progression of a people and culture in American society, artistically expressed by Mexican-American writers who seek to understand themselves and the world around them.
- 42 CONTEMPORARY MEXICAN LITERATURE** (UC:CSU) 3 UNITS
Prerequisite: None | Lecture 3 hrs
Same as Spanish 12 (Not offered at LAMC)
An introduction to contemporary Mexican literature and culture (with a background of earlier aesthetic works). Students read translations of major literary writers.
- 44 MEXICAN CIVILIZATION** (UC:CSU) 3 UNITS
Prerequisite: None | Lecture 3 hrs
Same as Spanish 16 (Not offered at LAMC)
This course considers the significant elements of pre-Columbian Mexican civilization, the impact of the Spanish domination upon the indigenous population and its influence upon mores, art, and industry. It introduces the students to studies in the history, literature, art, and music of Mexico as they evolved from colonial times to the present. The impact of the Mexican Revolution upon all the Americas is considered. It examines the present-day culture of Mexican-Americans as influenced by their Mexican heritage and life in the United States. The course is taught in English.
- 46 CHICANO & MEXICAN FOLKLORE** (UC:CSU) 3 UNITS
Prerequisite: None | Lecture 3 hrs
Introduction to conventional studies of Chicano/Mexicano folklore. Students will analyze and evaluate the various folklore genres: myths, legends, folktales, folk medicine, folk speech, and related topics in both a historical and contemporary social context.
- 47 MEXICAN-AMERICAN WOMAN IN CONTEMPORARY SOCIETY** (UC:CSU) 3 UNITS
Prerequisite: None | Lecture 3 hrs
Examines the socio-historical development of Chicanas in the U.S. It analyzes issues relating to feminism, gender politics, history, and community activism. The class assesses specific social issues which are central to the Chicana experience.
- 52 MEXICAN ART – MODERN** (UC:CSU) 3 UNITS
Prerequisite: None | Lecture 3 hrs
A survey of the art of Mexico from the nineteenth century to the present, including the renaissance of indigenous Mexican art, the evolution of a Mexican-American art, and the cultural interplay between the United States and Mexico.
- 54 MEXICAN-AMERICAN ARTS IN AMERICAN CULTURE** (UC:CSU) 3 UNITS
Prerequisite: None | Lecture 3 hrs
A study of Mexican and Mexican American arts, literature, and music. Particular emphasis is given to the identification of the contributions of Mexican and Mexican American artists to the contemporary culture of the United States.
- 58 LATIN-AMERICAN DANCE CULTURES** (UC:CSU) 3 UNITS
Prerequisite: None | Lecture 3 hrs
Focuses on Latin American folk dance appreciation, studying dance as culture, and how each region manifests its traditions, history, and lifestyle as expressed through movement. Students explore and analyze folk dances and how they are reflected by the worldview of people who practice them. They also analyze symbolic movements from selected dances to recognize the quality of movement and the relationship between religious and secular dances.
- 71 THE CHICANO IN LOS ANGELES** (CSU) 3 UNITS
Prerequisite: None | Lecture 3 hrs
A history of Chicanos in Los Angeles. It examines their role in Los Angeles political, economic, social, cultural, and intellectual history. It covers the period from the Native American era to the present.

Disciplines • Educational Programs • Course Descriptions

CHILD DEVELOPMENT CHILD & FAMILY STUDIES

FACULTY: Janice Silver, Chair | Lilamani de Silva
Patricia Rodriguez | Rita Grigoryan

EDUCATIONAL PROGRAMS

The Child Development Program offers students:

- Transfer Programs
- Career and Technical Education Programs and workforce preparation

The Child Development Program meets the diverse needs of students:

- Certificates
- Associate of Arts Degree in Child Development
- Associate in Science for Transfer (AS-T) - Early Childhood Education
- Child Development Permits issued by California Commission on Teacher Credentialing
- Coursework offered bilingually in English and Spanish
- Employment opportunities

COURSE AND PROGRAM RECOMMENDATIONS

To gain a better understanding of career and academic options within the field of Child Development, students are highly encouraged to enroll in Child Development 172 during the first or second semester of studies.

In order to meet Title 5 regulations to teach in a publicly funded program (e.g., Head Start, Early Education Center), a California Child Development Permit is required, which has 3 components:

1. 24 units of Child Development: included in the completion of a Child Development Certificate.
2. 21 units of General Education Requirements
3. Experience: Some of which may be fulfilled by the completion of Child Development 22 and 23

NOTE: If a student with a Bachelor's Degree in any major wants to earn a Child Development Permit, the student needs to complete 12 units in Child Development AND one practicum course, either Child Development 22 or 23, may waive the prerequisite of Child Development 22 to enroll in Child Development 23). If needed a waiver can be initiated through the counseling office.

Please check the Child Development permit matrix for further information: www.childdevelopment.org or call 209.572.6080.

NOTE: All Child Development courses must be completed with a grade of "C" or better.

The California Department of Education and the Department of Social Services Licensing Division require that all Child Development units be completed with a grade of "C" or higher.

CERTIFICATES OF ACCOMPLISHMENT*

(Total of 12 units)

- Child Development Certificate of Accomplishment
- Child Development Certificate of Accomplishment in Administration
- Family Child Care Certificate of Accomplishment

**To earn a Certificate of Accomplishment, all 12 units must be from Los Angeles Community College District.*

Child Development Certificate of Accomplishment

Students completing a Child Development Certificate of Accomplishment are qualified to teach in a private child development program as licensed under Title 22 of the Department of Social Services.

Program Learning Outcomes -

Upon completion, students will be able to:

- Integrate understanding of the needs, characteristics and multiple influences on development of children birth to age eight as it relates to high quality care and education of young children;

- Apply effective teaching and guidance strategies that support the learning outcomes of young children in early learning settings;
- Develop strategies to enhance positive socially and culturally respectful partnerships with parents, families and communities.

REQUIRED COURSES

REQUIRED COURSES	UNITS
ChDev 1 Child Growth & Development	3
ChDev 2 Early Childhood: Principles & Practices	3
ChDev 7 Intro to Curriculum in Early Childhood Education	3
ChDev 11 Child, Family & Community	3
Total	12

Child Development Certificate of Accomplishment in Administration**

Students completing a Child Development Certificate of Accomplishment in Administration have completed a specialization in the administration and supervision of programs and staff that provide for the care and education of young children.

Program Learning Outcomes -

Upon completion, students will be able to:

- Integrate understanding of the needs, characteristics and multiple influences on development of children birth to age eight as it relates to high quality care and education of young children;
- Apply effective supervision, coaching and mentoring strategies that support staff in their efforts to create high quality learning outcomes of young children in early learning settings.

REQUIRED COURSES

ChDev 38	Administration & Supervision of Early Childhood Programs I
ChDev 39	Administration & Supervision of Early Childhood Programs II
ChDev 65	Early Childhood Mentoring & Adult Supervision
ChDev 22 or ChDev 23	Practicum in Child Development I / Practicum in Child Development II

UNITS	3
	3
	2
	4
Total	12

Family Child Care Certificate of Accomplishment

Students completing a Family Child Care Certificate of Accomplishment are prepared with a specialization in providing care and education for children in a family child care setting under the regulation of Title 22 of the Department of Social Services.

Program Learning Outcomes –

Upon completion, students will be able to:

- Integrate understanding of the needs, characteristics and multiple influences on development of children birth to age eight as it relates to high quality care and education of young children.

REQUIRED COURSES

ChDev 1	Child Growth & Development
ChDev 10	Health, Safety & Nutrition
ChDev 60	Introduction to Family Child Care I
ChDev 61	Introduction to Family Child Care II
ChDev 62	Developmental Profiles: Pre-Birth through Eight
ChDev 63	Creative Curriculum in a Family Child Care Setting

UNITS	3
	3
	1
	1
	2
	2
Total	12

CERTIFICATES OF ACHIEVEMENT

Child Development (Total of 25 units)

This certificate also meets the major requirements for the Early Childhood Education AS-T Degree, see page 103.

Program Learning Outcomes –

Upon completion, students will be able to:

- Integrate understanding of the needs, the characteristics and multiple influences on development of children birth to age eight as related to high quality care and education of young children;
- Design, implement, and evaluate environments and activities that support positive, developmental play and learning outcomes for all young children;
- Apply professional standards of practice to the care and education of young children and families in early childhood settings.

REQUIRED COURSES

ChDev 1	Child Growth & Development	3
ChDev 2	Early Childhood: Principles & Practices	3
ChDev 7	Intro to Curriculum in Early Childhood Education	3
ChDev 10	Health, Safety & Nutrition	3
ChDev 11	Child, Family & Community	3
ChDev 22	Practicum in Child Development I	4
ChDev 34	Observation & Assessment	3
ChDev 42	Teaching in a Diverse Society	3
		Total: 25

Child Development (Total of 36 units)

All Child Development Certificates with areas of specialization, listed below, meet the major requirements for AA degree.

- Specializing in Preschool
- Specializing in Bilingual/Bicultural Preschool
- Specializing in Infant & Toddler
- Specializing in School-Age Child Care
- Specializing in Family Child Care
- Specializing in Special Needs

CHILD DEVELOPMENT CERTIFICATE Specializing in Preschool

Program Learning Outcomes –

Upon completion, students will be able to:

- Design, implement, and evaluate environments and activities that support positive, developmental play and learning outcomes for all young children;
- Apply professional standards of practice to the care and education of young children and families in early childhood settings.

REQUIRED COURSES

ChDev 1	Child Growth & Development	3
ChDev 2	Early Childhood: Principles & Practices	3
ChDev 7	Introduction to Curriculum in Early Childhood Education	3
ChDev 10	Health, Safety & Nutrition	3
ChDev 11	Child, Family & Community	3
ChDev 22	Practicum in Child Development I	4
ChDev 34	Observation & Assessment	3
ChDev 42	Teaching in a Diverse Society	3
ChDev 23	Practicum in Child Development II	4
ChDev 172	Introduction to Careers in Child Development	1
ChDev 8 or ChDev 3	Curriculum in Early Childhood Education / Creative Experiences for Children I	3
ChDev 45	Programs for Children with Special Needs	3
		Total 36

Disciplines • Educational Programs • Course Descriptions

CHILD DEVELOPMENT CERTIFICATE

Specializing in Bilingual/Bicultural Preschool

Program Learning Outcomes –

Upon completion, students will be able to:

- Design, implement, and evaluate environments and activities that support positive, developmental play and learning outcomes for all young children;
- Apply principles and practices based on sound understanding of dual language learners as it applies to an early learning setting;
- Apply professional standards of practice to the care and education of young children and families in early childhood settings.

REQUIRED COURSES		UNITS
ChDev 1	Child Growth & Development	3
ChDev 2	Early Childhood: Principles & Practices	3
ChDev 7	Introduction to Curriculum in Early Childhood Education	3
ChDev 10	Health, Safety & Nutrition	3
ChDev 11	Child, Family & Community	3
ChDev 22	Practicum in Child Development I	4
ChDev 34	Observation & Assessment	3
ChDev 42	Teaching in a Diverse Society	3
ChDev 23	Practicum in Child Development II	4
ChDev 172	Introduction to Careers in Child Development	1
ChDev 14	Bilingual/Bicultural Programs	3
ChDev 15	Creative Curriculum in Bilingual/Bicultural Programs	3

Total 36

CHILD DEVELOPMENT CERTIFICATE

Specializing in Infant & Toddler

Program Learning Outcomes –

Upon completion, students will be able to:

- Apply effective guidance and interaction strategies that support all children’s social learning, identity, and self-confidence;
- Apply principles and practices based on sound understanding of Infant and toddler development as it applies to an early learning setting;
- Apply professional standards of practice to the care and education of young children and families in early childhood settings.

REQUIRED COURSES		UNITS
ChDev 1	Child Growth & Development	3
ChDev 2	Early Childhood: Principles & Practices	3
ChDev 7	Introduction to Curriculum in Early Childhood Education	3
ChDev 10	Health, Safety & Nutrition	3
ChDev 11	Child, Family & Community	3
ChDev 22	Practicum in Child Development I	4
ChDev 34	Observation & Assessment	3
ChDev 42	Teaching in a Diverse Society	3
ChDev 23	Practicum in Child Development II	4
ChDev 172	Introduction to Careers in Child Development	1
ChDev 30	Infant and Toddler Studies I	3
ChDev 31	Infant and Toddler Studies II	3

Total 36

CHILD DEVELOPMENT CERTIFICATE

Specializing in School-Age Child Care

This Certificate is for persons seeking employment or who are employed in school age childcare programs.

Program Learning Outcomes –

Upon completion, students will be able to:

- Design, implement, and evaluate environments and activities that support positive, developmental play and learning outcomes for all young children;
- Apply principles and practices based on sound understanding of school age development as it applies to a school age learning setting.

REQUIRED COURSES		UNITS
ChDev 1	Child Growth & Development	3
ChDev 2	Early Childhood: Principles & Practices	3
ChDev 7	Intro to Curriculum in Early Childhood Education	3
ChDev 10	Health, Safety & Nutrition	3
ChDev 11	Child, Family & Community	3
ChDev 22	Practicum in Child Development I	4
ChDev 34	Observation & Assessment	3
ChDev 42	Teaching in a Diverse Society	3
ChDev 23	Practicum in Child Development II	4
ChDev 172	Introduction to Careers in Child Development	1
ChDev 46	School Age Programs I	3
ChDev 45	Programs for Children with Special Needs	3

Total 36

CHILD DEVELOPMENT CERTIFICATE Specializing in Family Child Care

This Certificate is designed for current or prospective family child care providers (individuals who operate a licensed child care program in their homes).

Program Learning Outcomes –

Upon completion, students will be able to:

- Design, implement, and evaluate environments and activities that support positive, developmental play and learning outcomes for all young children;
- Apply principles and practices based on sound understanding of the needs of mixed age groups of children in a family child care home.

REQUIRED COURSES		UNITS
ChDev 1	Child Growth & Development	3
ChDev 2	Early Childhood: Principles & Practices	3
ChDev 7	Introduction to Curriculum in Early Childhood Education	3
ChDev 10	Health, Safety & Nutrition	3
ChDev 11	Child, Family & Community	3
ChDev 22	Practicum in Child Development I	4
ChDev 34	Observation & Assessment	3
ChDev 42	Teaching in a Diverse Society	3
ChDev 23	Practicum in Child Development II	4
ChDev 172	Introduction to Careers in Child Development	1
ChDev 60	Introduction to Family Child Care 1	1
ChDev 61	Introduction to Family Child Care 11	1
ChDev 62	Developmental Profiles: Pre-Birth Through Eight	2
ChDev 63	Creative Curriculum in a Family Child Care Setting	2
Total 36		

CHILD DEVELOPMENT CERTIFICATE Specializing in Special Needs

This Certificate will support teachers and paraprofessionals working with children with special needs and/or Early Intervention Programs.

Program Learning Outcomes –

Upon completion, students will be able to:

- Design, implement, and evaluate environments and activities that support positive, developmental play and learning outcomes for all young children;
- Apply principles and practices based on sound understanding of the needs of children with differing abilities as it applies to an early learning setting and/or natural environment;
- Apply professional standards of practice to the care and education of young children and families in early childhood settings.

REQUIRED COURSES		UNITS
ChDev 1	Child Growth & Development	3
ChDev 2	Early Childhood: Principles & Practices	3
ChDev 7	Introduction to Curriculum in Early Childhood Education	3
ChDev 10	Health, Safety & Nutrition	3
ChDev 11	Child, Family & Community	3
ChDev 22	Practicum in Child Development I	4
ChDev 23	Practicum in Child Development II	4
ChDev 34	Observation & Recording Children's Behavior	3
ChDev 42	Teaching in a Diverse Society	3
ChDev 44	Early Intervention for Children with Special Needs	3
or ChDev 55	Home Visitation Programs	
ChDev 45	Programs for Children with Special Needs	3
ChDev 172	Introduction to Careers in Child Development	1
Total 36		

ASSOCIATE DEGREE - Child Development

1) ASSOCIATE IN ARTS – Child Development

- Completion of any one of the six Child Development Certificates with Specialization (36 units), as listed below:
 - Specializing in Preschool
 - Specializing in Bilingual/Bicultural Preschool
 - Specializing in Infant & Toddler
 - Specializing in School-Age Child Care
 - Specializing in Family Child Care
 - Specializing in Special Needs
- Completion of General Education Requirements, see page 73

2) ASSOCIATE IN SCIENCE FOR TRANSFER (AS-T)- Early Childhood Education

- This transfer degree will allow students to transfer to a CSU as a Child Development, Human Development, and Early Childhood Education or related major.
- Completion of General Education Transfer Requirements (CSU GE/IGETC)

NOTE: A minimum of 60 units and a cumulative GPA of 2.0 or higher must be completed to earn the Associate Degree. Always consult a counselor for information on graduation requirements, residency requirements and transfer information.

Disciplines • Educational Programs • Course Descriptions

Associate in Science for Transfer (AS-T) Early Childhood Education

Program Learning Outcomes –

Upon completion, students will be able to:

- Integrate understanding of the needs, characteristics and multiple influences on development of children birth to age eight as it relates to high quality care and education of young children;
- Design, implement, and evaluate environments and activities that support positive, developmental play and learning outcomes for all young children;
- Apply professional standards of practice to the care and education of young children and families in early childhood settings.

REQUIRED CORE

		UNITS
ChDev 1	Child Growth & Development	3
ChDev 2	Early Childhood: Principles & Practices	3
ChDev 7	Intro to Curriculum in Early Childhood Education	3
ChDev 10	Health, Safety & Nutrition	3
ChDev 11	Child, Family & Community	3
ChDev 22	Practicum in Child Development I	4
ChDev 34	Observation & Assessment	3
ChDev 42	Teaching in a Diverse Society	3

Total 25

1 CHILD GROWTH & DEVELOPMENT (UC:CSU) 3 UNITS

Prerequisite: None | Lecture 3 hrs

Examines the major physical, psychosocial, and cognitive/language developmental milestones for children, both typical and atypical, from conception through adolescence. Emphasis is placed on interactions between maturational processes and environmental factors. While studying developmental theory and investigative research methodologies, students will observe children, evaluate individual differences and analyze characteristics of development at various stages.

2 EARLY CHILDHOOD: PRINCIPLES & PRACTICES (CSU) 3 UNITS

Corequisite: ChDev 1 | Lecture 3 hrs

The student will explore the history of early childhood education as well as current philosophies and practices. Early Childhood programs will be observed and examined in relation to the needs of the child, the arrangement of the environment and the role of the teacher.

3 CREATIVE EXPERIENCES FOR CHILDREN I (CSU) 3 UNITS

Prerequisite: None | Lecture 3 hrs

Explores the creative approach to program planning in areas of sensory, motor, manipulative, art, dramatic play, puppetry, blocks, music and movement. Students will develop and implement creative curriculum for young children. Emphasis is on environments that promote creativity and the role of the teacher.

4 CREATIVE EXPERIENCES FOR CHILDREN II (CSU) 3 UNITS

Prerequisite: None | Lecture 3 hrs

The creative approach to program planning in language arts, mathematics, social studies, science, perceptual motor and cooking will be explored. Emphasis will be on methods of presentation, values and teaching/learning styles.

7 INTRODUCTION TO CURRICULUM IN EARLY CHILDHOOD EDUCATION (CSU) 3 UNITS

Prerequisite: ChDev 2 | Lecture 3 hrs

Exploration of appropriate curriculum and environments for young children. Students examine a teacher's role in supporting development and positive learning experiences for all young children using observation and assessment strategies and emphasizing the essential role of play. Planning, implementation and evaluation of curriculum

includes but is not limited to: language and literacy, social and emotional learning, sensory learning, art and creativity, math, natural and physical sciences.

8 CURRICULUM IN EARLY CHILDHOOD EDUCATION (CSU) 3 UNITS

Prerequisite: ChDev 2 | Lecture 3 hrs

Students design and evaluate developmentally appropriate curriculum and environments for young children from birth to age 8. Based on the value of play, students demonstrate the teacher's role in applying theory to practice in supporting children's concept development. Preparing and assessing the implementation of curriculum will include but not be limited to: language and literacy, social studies, art and creativity, music and rhythm, physical and motor mastery, mathematics, and physical sciences.

10 HEALTH, SAFETY & NUTRITION (CSU) 3 UNITS

Prerequisite: None | Lecture 3 hrs

Study of the laws, regulations, standards, policies, procedures and early childhood curriculum related to child health, safety and nutrition. Key components that ensure physical health, mental health, and safety for children and staff are identified along with importance of collaboration with families and health professionals. The interrelationship of health, safety and nutrition and the impact on children's growth and development are key areas of focus.

11 CHILD, FAMILY & COMMUNITY (CSU) 3 UNITS

Prerequisite: None | Lecture 3 hrs

Introduces the student to the effects of the home, the school and the community on the development and experience of the child. Issues, challenges and concerns will be explored as well as the importance of developing partnerships.

- 14 BILINGUAL-BICULTURAL PROGRAMS** (CSU) 3 UNITS
Prerequisite: None | Lecture 3 hrs
A general overview of bilingual-bicultural education, including programs for English language learners. Students gain an historical perspective of bilingual-bicultural education in the U.S., as well as, an in-depth view of current programs for English language learners.
- 15 CREATIVE CURRICULUM IN BILINGUAL/BICULTURAL PROGRAMS** (CSU) 3 UNITS
Prerequisite: None | Lecture 3 hrs
An overview of bilingual, bicultural resources available for educators of English Language Learners. Skills in research techniques to find these resources will be acquired. Curriculum development and lesson planning will be stressed.
- 22 PRACTICUM IN CHILD DEVELOPMENT I** (CSU) 4 UNITS
Prerequisite: ChDev 4 or 7, and ChDev 1, 2 & 11, Eng 28 or ESL 8 | Lecture 2 hrs, Lab 6 hrs
NOTE: Students must show proof of a current negative TB test (Mantoux Test) or chest x-ray within the last two years.
NOTE: Total of 90 hours of supervised field experience.
Supervised experience in a preschool, child development center, elementary school, special education center, or other childcare and education setting. The student will relate all previous theory and curriculum courses to practical application in the classroom.
- 23 PRACTICUM IN CHILD DEVELOPMENT II** (CSU) 4 UNITS
Prerequisites: English 28 or ESL 8, ChDev 22 and TB clearance | Lecture 2 hrs, Lab 6 hrs
NOTE: Total of 90 hours of supervised field experience.
The second semester of practicum teaching experience in a different setting, if possible, under the supervision of a master teacher or college instructor/coordinator. This course provides the practical application of theories covered in prerequisite courses.
- 30 INFANT & TODDLER STUDIES I** (CSU) 3 UNITS
Prerequisite: None | Lecture 3 hrs
Reviews physical, social-emotional, language and cognitive development during the period of infancy and toddlerhood. Focus is on infant/toddler group care and licensing regulations related to this age. The course also addresses the role of the caregiver in meeting the needs of infants and toddlers and their families through responsive, respectful and sensitive caregiving practices. Varying philosophies and issues of diversity are explored.
- 31 INFANT & TODDLER STUDIES II** 3 UNITS
Prerequisite: None | Lecture 3 hrs
The principles of inclusive and respectful caregiving for infants and toddlers within a variety of program designs will be studied and analyzed. Attention will be given to designing environments and curriculum that support current research into brain theory, language development, assessment, early intervention, and inclusion practices.
- 34 OBSERVING & RECORDING CHILDREN'S BEHAVIOR** (CSU) 3 UNITS
Prerequisite: ChDev 2 | Lecture 3 hrs
NOTE: Students must show proof of a current negative TB test (Mantoux Test) or chest x-ray within the last two years.
Appropriate use of assessment and observation strategies to document development, growth, play and learning to join with families and professionals in promoting children's success. Recording strategies, rating systems, portfolios, and multiple assessment tools are explored.
- 38 ADMINISTRATION & SUPERVISION OF EARLY CHILDHOOD PROGRAMS I** (CSU) 3 UNITS
Prerequisite: ChDev 1, ChDev 2, ChDev 11 and ChDev 3 or ChDev 7 or ChDev 8 | Lecture 3 hrs
Prepares students to establish and administer an early childhood program. Financial aspects of administration, legal rules and regulations pertaining to administration are emphasized. Concepts of budgeting, personnel management, marketing, as well as mentoring and working with families are explored.
- 39 ADMINISTRATION & SUPERVISION OF EARLY CHILDHOOD PROGRAMS II** (CSU) 3 UNITS
Prerequisite: ChDev 38 | Lecture 3 hrs
Provides training for administrators of Early Childhood Programs, private and public. Topics include: state and federal regulations, grant and proposal writing, advocacy, supervision and staff development, conflict resolution, leadership skills and team management techniques, appropriate computer applications, family partnership, current assessment tools, legal issues, and disaster preparedness.
- 42 TEACHING IN A DIVERSE SOCIETY** (CSU) 3 UNITS
Prerequisite: None | Lecture 3 hrs
Examines the development of social identities in diverse societies including theoretical and practical implications of oppression and privilege as they apply to young children, families, programs, classrooms and teaching. Various classroom strategies will be explored emphasizing culturally and linguistically appropriate anti-bias approaches supporting all children in becoming competent members of a diverse society.
- 44 EARLY INTERVENTION FOR CHILDREN WITH SPECIAL NEEDS** (CSU) 3 UNITS
Prerequisite: None | Lecture 3 hrs
Designed for students interested in working with young children with special needs and their families. Instruction focuses on accommodating and adapting the physical environment, instructional strategies and curriculum to meet the needs of differently abled children from birth to preschool.
- 45 PROGRAMS FOR CHILDREN WITH SPECIAL NEEDS** (CSU) 3 UNITS
Prerequisite: None | Lecture 3 hrs
Overview of programs providing special education services for children with special needs focusing on preschool through school age. Includes a study of various programs, legislation, characteristics of exceptionalities and educational implications. Observation in schools will be required.

Disciplines • Educational Programs • Course Descriptions

46 SCHOOL AGE PROGRAMS I (CSU) 3 UNITS

Prerequisite: None | Lecture 3 hrs

Examines school age care programs for those planning to work in before and after school programs. Students will explore the developmental needs of school age children, program models, creation of environments, classroom management techniques and designing developmentally appropriate experiences and curriculum.

55 HOME VISITATION PROGRAMS (CSU) 3 UNITS

Prerequisite: None | Lecture 3 hrs

Examines the emerging field of home visitation as it relates to programs offering in home support and intervention services. Prepares the student to conduct home visitations in a variety of contexts including early intervention, family support systems, gerontology and publicly funded early childhood programs.

60 INTRODUCTION TO FAMILY CHILD CARE I (CSU) 1 UNIT

Prerequisite: None | Lecture 1 hr

Designed for family child care providers and persons entering the profession. Focuses on high quality physical environments in a home setting, age-appropriate activities for mixed age groups, communication with parents, and community resources. Includes field study of accredited programs.

61 INTRODUCTION TO FAMILY CHILD CARE II (CSU) 1 UNIT

Prerequisite: None | Lecture 1 hr

An in-depth study of the business aspects of Family Child Care Programs: Contracts, Advertising, Budgets, Recordkeeping, Staff Relations, working with Parents and Licensing Regulations. Reviewing and utilizing the Family Home Day Care Rating Scale for facilities in evaluating and assessing the classroom and teacher effectiveness.

62 DEVELOPMENTAL PROFILES: PRE-BIRTH THROUGH AGE EIGHT (CSU) 2 UNITS

Prerequisite: None | Lecture 2 hrs

Provides the study of concise developmental profiles from pre-birth through age eight. Key concepts in current child development literature, development of curriculum plan and children's developmental assessment tools will be examined.

63 CREATIVE CURRICULUM IN A FAMILY CHILD CARE SETTING (CSU) 2 UNITS

Prerequisite: None | Lecture 2 hrs

Designed for family childcare providers and persons entering the profession. Emphasis is on play and creative experiences in the home setting for children. Course includes dramatic play, music, art, cooking.

65 ADULT SUPERVISION/EARLY CHILDHOOD MENTORING 2 UNITS

Prerequisite: ChDev 23 and 38 | Lecture 2 hrs

Methods and principles of supervising adults in early childhood education settings with emphasis on the role of administrators and experienced teachers acting as mentors to new teachers. This course is required for upper levels of the California Child Development Permit, and to become a California Early Childhood Mentor.

172 INTRODUCTION TO CAREERS IN CHILD DEVELOPMENT 1 UNIT

Prerequisite: None | Lecture 1 hr

Introduces students to the variety of career options available to Child Development majors. It explores career opportunities, qualifications required, resources available, as well as academic and professional support systems.

185 DIRECTED STUDY (CSU) 1 UNIT

Provides opportunity for in-depth study of a chosen area of Child Development on a contract basis, under the direction of a supervising instructor. Credit limit: Maximum of 3 units may be taken for credit.

285 DIRECTED STUDY (CSU) 2 UNITS

Provides opportunity for in-depth study of a chosen area of Child Development on a contract basis, under the direction of a supervising instructor. Credit limit: Maximum of 3 units may be taken for credit.

385 DIRECTED STUDY (CSU) 3 UNITS

Provides opportunity for in-depth study of a chosen area of Child Development on a contract basis, under the direction of a supervising instructor. Credit limit: Maximum of 3 units may be taken for credit.

CINEMA

ARTS, MEDIA & PERFORMANCE

FACULTY: Deborah Paulsen, Chair

Curtis Stage, Vice-Chair | Huy (John) Huynh

3 HISTORY OF MOTION PICTURES (UC:CSU) 3 UNITS

Prerequisite: None | Lecture 2 hrs, Lab 2 hrs

Covers classics and important films from the birth of the medium to the present time. Films are screened and discussed with regard to their cultural influence. The course follows the evolution of the art, industry and technology involved in movie making.

4 HISTORY OF THE DOCUMENTARY FILM (UC:CSU) 3 UNITS

Prerequisite: None | Lecture 2 hrs, Lab 2 hrs

Examines the development of documentary and non-narrative films from the 1890's to present day. Includes historical, propaganda, educational, commercial, cinéma vérité and direct cinema. Students will develop critical standards for judging documentary films.

COMMUNICATION STUDIES

ENGLISH & COMMUNICATION STUDIES

FACULTY: Dr. Louise Barbato, Chair
Margie Long, Vice-Chair

Associate in Arts for Transfer (AA-T) Communication Studies

The Associate in Arts (AA) Degree in Communication Studies will provide the student with a firm basic foundation in the principles of effective communication, communication processes and communication styles. This degree will allow the student to transfer to a CSU as a Communication Studies major or in a related major.

Communication is the study of how human beings communicate. People who study Communication are interested in learning how the communication process works and desire to improve and adapt their communication for intended recipients. Courses in the Communication degree examine the mechanisms of communication in public, groups, cultures and interpersonal settings. In addition, the student will explore the nature of argumentation and the ability to critically evaluate messages as both the sender and receiver. The Communication degree can lead to careers in broadcasting, teaching, business, marketing, law, journalism, public relations, and consulting.

Program Learning Outcomes –

Upon completion, students will be able to:

- Analyze speech to identify underlying logic and point of view;
- Develop a well-organized speech which develops cogent main ideas stated in a thesis and preview and which has adequate support for statements made;
- Utilize diverse sources of information to research a topic;
- Attribute quotes and other information gleaned from print and electronic sources, according to MLA style;
- Evaluate arguments for validity, objectivity and soundness;

- Argue a point after having gathered and synthesized relevant information, data and evidence;
- Critique speech in terms of content and delivery;
- Distinguish fallacies in arguments and be able to recognize the validity or lack of validity of various points of view in a speech.

REQUIRED CORE		UNITS
Comm 101	Oral Communication I	3
LIST A: Select two (2) courses		
Comm 121	The Process of Interpersonal Communication	3
Comm 151	Small Group Communication	3
LIST B: Select two (2) courses		
Comm 102	Oral Communication II	6
Anthro 104	Human Language & Culture	
MultiMd 110	Visual Communication	
or Any LIST A course not already used		
LIST C: Select one (1) course		
English 102	College Reading & Composition II	6
English 103	Composition & Critical Thinking	
Anthro 102	Human Ways of Life: Cultural Anthropology	
Soc 1	Introduction to Sociology	
Psych 1	General Psychology 1	
or Any LIST A or LIST B course not already used		

Total 18

NOTE: A minimum of 60 units and a cumulative GPA of 2.0 or higher must be completed to earn the Associate in Arts for Transfer. Always consult a counselor for information on graduation requirements, residency requirements and transfer information.

101 ORAL COMMUNICATION I (UC:CSU) 3 UNITS
Advisory: English 28 | Lecture 3 hrs
Introduction to techniques of public speaking including writing and delivery of speeches to inform and persuade. Students refine critical thinking, research, organizational, and time management skills. They learn to adapt a message to any audience and occasion.



102 ORAL COMMUNICATION II (UC:CSU) 3 UNITS

Advisory: English 28 | Lecture 3 hrs
Introduction to advanced phases of critical thinking, research, and public speaking. Course includes comprehension of structure, evaluation of arguments, researching and presenting evidence, language usage, and evaluation of fallacious reasoning. Adherence to ethics stressed in all communication settings.

121 THE PROCESS OF INTERPERSONAL COMMUNICATION (UC: CSU) 3 UNITS

Advisory: English 28 | Lecture 3 hrs
Designed to provide skills and fuller understanding of how individuals cope with social interactions that build, maintain or dissolve interpersonal relationships with friends, significant others, family members and coworkers.

151 SMALL GROUP COMMUNICATION (UC:CSU) 3 UNITS

Advisory: English 28 | Lecture 3 hrs
Provides an analysis of the purposes, principles, and types of group communication processes. Development of individual skills in leadership and problem solving is achieved by responsible group participation.

Disciplines • Educational Programs • Course Descriptions

COMPUTER APPLICATIONS & OFFICE TECHNOLOGIES

BUSINESS / LAW

FACULTY: Vilma Bernal, Chair | Joyce Woodmansee

EDUCATIONAL PROGRAMS

ASSOCIATE IN ARTS Computer Applications & Office Technologies

The individual pursuing the two-year program in Computer Applications and Office Technologies, which leads to the Associate in Arts Degree, will receive training in both the skills and the concept knowledge necessary for success in the business world.

NOTE: A minimum of 60 units and a cumulative GPA of 2.0 or higher must be completed to earn the Associate in Arts Degree. Always consult a counselor for information on graduation requirements, residency requirements and transfer information.

Program Learning Outcomes –

Upon completion, students will be able to:

- Create professional office documents using the Microsoft Office Suite including Word, Excel, Access, PowerPoint and the Microsoft Windows Operating System;
- Use effective oral, written communication, and teamwork skills to solve business problems and make decisions;
- Competently use a wide variety of office equipment including computers, printers, and calculators;
- Employ time management and organizational skills to work productively in an office environment.



REQUIRED COURSES

CAOT 1	Keyboarding I
CAOT 2	Keyboarding II
CAOT 31	Business English
CAOT 32	Business Communications
CAOT 33	Records Management & Filing
CAOT 34	Business Terminology
CAOT 82	Microsoft Office Survey
CAOT 84	Microcomputer Office Applications: Word Processing
CAOT 85	Microsoft Office Applications: Spreadsheet
CAOT 86	Microcomputer Office Applications: Database
CAOT 92	Microcomputer Applications: Windows Operating System
CAOT 105	School-to-Work Portfolio
CAOT 108	Presentation Design for the Office
CAOT 150	Social Media for Business

UNITS

3
3
3
3
2
2
3
3
3
3
2
2
2
3
Total 37

CERTIFICATES OF ACCOMPLISHMENT

The student will be given a Certificate of Accomplishment following the completion of any of the following programs if the student has maintained a minimum of a C grade in all required courses. Certificate of Accomplishment are for students who have limited time and wish to limit their commitment but desire an increased level of Specialization. Most courses taken in the programs apply toward curriculum leading to a Certificate of Achievement or the Associate Degree.

Communications Certificate of Accomplishment

Program Learning Outcomes –

Upon completion, students will be able to:

- Use effective oral, written communication, and teamwork skills to solve business problems and make decisions.

REQUIRED COURSES

CAOT 31	Business English	3
CAOT 32	Business Communications	3
CAOT 34	Business Terminology	2
CAOT 150	Social Media for Business	3
		Total 11

Computer Applications Certificate of Accomplishment

Program Learning Outcomes –

Upon completion, students will be able to:

- Create professional office documents using the Microsoft Office Suite including Word, Excel, Access, PowerPoint and the Microsoft Windows Operating System.

REQUIRED COURSES		UNITS
CAOT 82	Microcomputer Software Survey	3
CAOT 84	Microcomputer Office Applications: Word Processing	3
CAOT 85	Microcomputer Office Applications: Spreadsheet	3
CAOT 92	Microcomputer Applications: Windows Operating System	2

Total 11

Office Assistant Certificate of Accomplishment

Program Learning Outcomes –

Upon completion, students will be able to:

- Create professional office documents using the Microsoft Office Suite including Word, Excel, Access, PowerPoint and the Microsoft Windows Operating System;
- Competently use a wide variety of office equipment including computers, printers, and calculators;
- Employ time management and organizational skills to work productively in an office environment.

REQUIRED COURSES		UNITS
CAOT 2	Keyboarding II	3
CAOT 6	Electronic Calculators	1
CAOT 31	Business English	3
CAOT 33	Records Management & Filing	2
CAOT 34	Business Terminology	2
CAOT 82	Microcomputer Software Survey	3
CAOT 92	Microcomputer Applications: Windows Operating System	2

Total 16

1 KEYBOARDING I (CSU) 3 UNITS

Prerequisite: None | Lecture 2 hrs, Lab 3 hrs

In this beginning computer keyboarding course, students will learn how to key by touch while developing speed and accuracy with the goal of achieving 30 words per minute by the end of the semester. Students also will learn how to use Microsoft Word to format letters, memos, tables, and reports.

2 KEYBOARDING II 3 UNITS

Advisory: CAOT 1 | Lecture 2 hrs, Lab 3 hrs

An intermediate keyboarding course designed to further develop speed and accuracy in computer keyboarding to at least 40 words a minute. Emphasizes keyboarding and formatting letters, memos, reports, and business forms using Microsoft Word and introduces formatting of medical and legal documents.

3 KEYBOARDING III 3 UNITS

Prerequisite: None | Lecture 2 hrs, Lab 3 hrs

An advanced course designed to develop speed and accuracy in computer keyboarding to at least 50 words a minute. Students will learn how to handle integrated office projects using Microsoft Word to produce legal, medical, insurance, banking, travel, government, and energy documents.

6 ADDING AND CALCULATING MACHINES (CSU) 1 UNIT

Prerequisite: None | Lab 2 hrs

Develops skill in using the ten-key calculator and the computer numeric keypad to do basic mathematical operations. Develops the ability to use the ten-key numeric pad by touch. Reviews basic math concepts and develops the ability to solve computation problems by using a variety of mathematical and business functions.

9 COMPUTER KEYBOARDING IMPROVEMENT (CSU) 1 UNIT

Prerequisite: None | Lab 3 hrs

Designed to increase keyboarding speed and accuracy through specific drills and timings.

20 MEDICAL OFFICE PROCEDURES (CSU) 5 UNITS

Prerequisite: None | Lecture 4 hrs, Lab 2 hrs

An instructional and practical application course that facilitates the development of skills necessary for participants to become effective medical office administrative assistants. Students will be exposed to various components of medical office operations, terminology, insurance billing procedures, and communication skills through the use of concepts, principles, research, and practical application techniques.

31 BUSINESS ENGLISH (CSU) 3 UNITS

Prerequisite: None | Lecture 3 hrs

A review of fundamental English language skills necessary for written and oral communication in business. Students develop competency in English usage through review of parts of speech, punctuation, and sentence structure. Develops ability to write logical, concise, coherent sentences and paragraphs. After successful completion of this course, students will be prepared for CAOT 32, Business Communications.

32 BUSINESS COMMUNICATIONS (CSU) 3 UNITS

Advisory: CAOT 1 and CAOT 31

Lecture 3 hrs

Emphasizes the concepts of successful written and oral communication in business in order to write effective business communications including letters, electronic communications, and short reports. Develops the ability to create and present oral presentations.

Disciplines • Educational Programs • Course Descriptions

- 33 RECORDS MANAGEMENT & FILING** 2 UNITS
Prerequisite: None | Lecture 1 hr, Lab 2 hrs
Provides an overview of the field of records management; alphabetic, subject, numeric, and geographic storage and retrieval systems; records management technology; and records control. Class includes records management theory using Microsoft Access.
- 34 BUSINESS TERMINOLOGY** (CSU) 2 UNITS
Prerequisite: None | Lecture 2 hrs
Develops and builds vocabulary with an emphasis on business terminology and improvement of ability to recognize, use and spell words correctly. Understanding of root words, suffixes, prefixes, synonyms, antonyms, business-related terminologies, computer-related terminologies and expansion of personal vocabularies is emphasized to help prepare students for not only a business career but also for consumer transactions in today's world.
- 64 COMPUTER APPLICATIONS & OFFICE TECHNOLOGIES LABORATORY** (CSU) 1 UNIT
Prerequisite: None | Lab 2 hrs
Co-requisite: Choose one of the following: CAOT 1, 2, 6, 31, 32, 33, 34, 76, 78, 82, 84, 85, 86, 92, 105, 108, 150, or 255.
NOTE: Class is graded pass/no-pass
Develops competency in the subject areas taught in the Computer Applications and Office Technologies Department. Designed as an aid to students who need additional time and practice to increase their knowledge and skills in any Computer Applications and Office Technologies course.
- 76 KEYBOARDING FOR DATA PROCESSING** 1 UNIT
Prerequisite: None | Lab 2 hrs
Designed to meet the needs of students by giving them the skills necessary to keyboard efficiently and accurately.
- 78 MICROCOMPUTER ACCOUNTING APPLICATIONS FOR THE ELECTRONIC OFFICE** (CSU) 3 UNITS
Advisory: Acctg 1 or 21 | Lecture 1 hr, Lab 4 hrs
Acquaints students with the use of the microcomputer for bookkeeping and accounting applications. Students receive hands-on experience in analyzing business transactions, keeping records, preparing financial statements, and generating financial management reports using an accounting software package such as QuickBooks.
- 82 MICROCOMPUTER SOFTWARE SURVEY IN THE OFFICE** (CSU) 3 UNITS
Advisory: CAOT 1 | Lecture 2 hrs, Lab 3 hrs
Introduces students to the use of the computer and software used in the business Office. Provides hands on introduction to Microsoft Word, Excel, Access, and PowerPoint. Students gain basic knowledge necessary for using computers and becoming computer literate.
- 84 MICROCOMPUTER OFFICE APPLICATIONS: WORD PROCESSING (MICROSOFT WORD)** 3 UNITS
Advisory: CAOT 1 | Lecture 2 hrs, Lab 3 hrs
Emphasizes learning how to use basic and advanced commands in Microsoft Word to create, format, edit, save, and print documents including letters, tables, reports, and merge documents. Desktop publishing features are used to create newsletters, brochures, fliers, and resumes.
- 85 MICROSOFT OFFICE APPLICATIONS: SPREADSHEET (EXCEL)** (CSU) 3 UNITS
Prerequisite: None | Lecture 2 hrs, Lab 3 hrs
Use Excel to plan, present, manipulate, and calculate numerical data by writing formulas with mathematical operators, linking workbooks and sharing workbooks. Format worksheets with advanced techniques, visual charts, and clip art images.
- 86 MICROCOMPUTER OFFICE APPLICATIONS: DATABASE (ACCESS)** (CSU) 3 UNITS
Prerequisite: None | Lecture 2 hrs, Lab 3 hrs
Use Access to plan, design, create, use, and maintain databases. Use Access to create forms, reports, queries, charts, mailing labels, PivotTables, and PivotCharts. Learn to import data, export data, and create links between other Microsoft Office applications.
- 92 COMPUTER WINDOWS APPLICATION** (CSU) 2 UNITS
Prerequisite: None | Lecture 1 hr, Lab 2 hrs
Utilize and more effectively manage computers and files using the Windows 7 operating system, including using the Control Panel settings to customize a computer, using the accessory functions, and optimizing a computer by using the disk management and security features.
- 105 SCHOOL-TO-WORK PORTFOLIO** 2 UNITS
Prerequisite: None | Lecture 2 hrs
Students prepare a comprehensive professional portfolio that contains a resume, cover letter, application for employment, reference letters, and personal achievement. The course will also include career planning, networking with business and industry, and job search using the Internet and other resources.

108 PRESENTATION DESIGN FOR THE OFFICE (CSU) 2 UNITS

Prerequisite: None | Lecture 1 hr, Lab 2 hrs
Provides an overview of presentation design software. Students learn to use PowerPoint templates, outlines, clip art, and Microsoft Office documents to create presentations, electronic slide shows, and websites.

126 INTRODUCTION TO MEDICAL CODING/BILLING 3 UNITS

Advisory: CAOT 1 or 82 | Lecture 3 hrs
Introduces students to the skills necessary to become proficient in basic medical office billing and coding procedures (Procedural Coding CPT as well as ICD-9-CM Diagnostic Coding). Includes practice processing insurance claims and managing patient insurance billing and reimbursement using medical programming software.

150 SOCIAL MEDIA FOR BUSINESS (CSU) 2 UNITS

Advisory: CAOT 82 | Lecture 1 hr, Lab 4 hrs
Emerging trends and the impact of social media as it applies to business. Areas of coverage will include how to promote business on popular social networking websites, web marketing, video sharing, blogging, RSS feeds, and maximizing response rate. Legal, ethical, and political implications will be addressed. Students will learn how social media can be used to create, promote, and expand a business online.

255 ELECTRONIC COMMERCE (E-COMMERCE) (CSU) 3 UNITS

Advisory: CAOT 82 | Lecture 3 hrs
Introduces the theory and practice of conducting business over the Internet and World Wide Web. Covers the key business and technology elements of electronic commerce including technology infrastructure, selling and marketing on the web, business-to-business strategies, virtual communities and web portals, web server hardware and software, electronic commerce software and electronic commerce security.

185 DIRECTED STUDY (CSU) 1 UNIT

Provides opportunity for in-depth study of a chosen area of Computer Applications and Office Technology on a contract basis, under the direction of a supervising instructor.

285 DIRECTED STUDY (CSU) 2 UNITS

Provides opportunity for in-depth study of a chosen area of Computer Applications and Office Technology on a contract basis, under the direction of a supervising instructor.

385 DIRECTED STUDY (CSU) 3 UNITS

Provides opportunity for in-depth study of a chosen area of Computer Applications and Office Technology on a contract basis, under the direction of a supervising instructor.

COMPUTER SCIENCE INFORMATION TECHNOLOGY

MATHEMATICS / COMPUTER SCIENCE

FACULTY: Debby Wong, Chair | Mari Rettke, Vice Chair
Paul Kubicki | Milan Samplewala

The Computer Science lab is a Microsoft Authorized Testing Center for MOS certification for both students and the general community. Practice tests are available.

The Computer Science Department is a member of the Microsoft Alliance which permits distribution of Microsoft operating systems and other programs to students enrolled in Computer Science courses.

EDUCATIONAL PROGRAMS

Associate in Arts (Computer Science Emphasis or Business Emphasis): These courses are designed both for those students desiring to pursue a transfer curriculum in Computer Science-Information Technology, and for those students wishing a terminal program and an Associate in Arts Degree in Computer Science. Questions about the program should be taken to the Faculty Advisor - Mari Rettke at 818.609.4761.

NOTE: A minimum of 60 units and a cumulative GPA of 2.0 or higher must be completed to earn the Associate in Arts Degree. Always consult a counselor for information on graduation requirements, residency requirements and transfer information.

ASSOCIATE IN ARTS - Computer Science

For General Education Requirements, see page 73

Program Learning Outcomes -

Upon completion, students will be able to:

- Demonstrate a basic understanding of computer hardware and software;
- Demonstrate basic level of competency in programming and logic skills;
- Utilize web technologies;
- Present conclusions effectively, orally and in writing;
- Use productivity software effectively (word processing, spreadsheets, and database software);
- Identify an area of interest through the selection of elective courses;
- Be competitive in the computing job market or be admitted to a bachelors program in computing.

REQUIRED COURSES

	UNITS
CoSci 401 Introduction to Computers & Their Uses	3
CoSci 407 Programming Logic	3
CoSci 408 Visual Basic	3
CoSci 430 Microcomputer Applications Software I	3
CoSci 431 Microcomputer Applications Software II	3
CoSci 439 Programming in C	3
CoSci 440 Programming in C ++	3
CoSci 450 Electronic Publishing II	3
CoSci 452 Programming in Java	3
CoSci 487 Introduction to Local Area Networks	3

Total 30

Disciplines • Educational Programs • Course Descriptions

ASSOCIATE IN ARTS - Computer Science: Business

For General Education Requirements, see page 73

Program Learning Outcomes –

Upon completion, students will be able to:

- Demonstrate a basic understanding of computer hardware and software;
- Demonstrate basic level of competency in programming and logic skills;
- Utilize web technologies;
- Present conclusions effectively, orally and in writing;
- Use productivity software effectively (word processing, spreadsheets, and database software);
- Identify an area of interest through the selection of elective courses;
- Be competitive in the computing job market or be admitted to a bachelors program in computing.

REQUIRED COURSES

		UNITS
Acctg 21	Bookkeeping and Accounting I	3
Bus 5* or Law 1	Business Law I	3
CoSci 401	Introduction to Computers & Their Uses	3
CoSci 407	Programming Logic	3
CoSci 408	Visual Basic	3
CoSci 430	Microcomputer Applications Software I	3
CoSci 431	Microcomputer Applications Software II	3
CoSci 439	Programming in C	3
CoSci 450	Electronic Publishing II	3
CoSci 452	Programming in Java	3
CoSci 487	Introduction to Local Area Networks	3
Econ 1	Principles of Economics I	3

Total 36

* Business majors are encouraged to complete courses within the Business Department.

CERTIFICATE OF ACHIEVEMENT Computer Science & Information Technology

At the completion of the program a Certificate will be awarded to the student who completes the course or study with a 2.00 average. These Certificates are primarily for those students who have a limited time to pursue their formal education and wish to specialize in a particular area of Computer Science that is job related.

They may seek advancement in their present job, or they may prepare themselves for different or new employment. Many courses taken in the program apply toward an Associate Degree. See Faculty Advisor – Mari Rettke – 818.609.4761 for substitutions.

Computer Science: Microcomputer Applications Management Certificate Program Learning Outcomes –

Upon completion, students will be able to:

- Demonstrate a basic understanding of computer hardware and software.

REQUIRED COURSES

		UNITS
CoSci 401	Introduction to Computers & Their Uses	3
CoSci 407	Programming Logic	3
CoSci 408	Visual Basic	3
CoSci 430	Microcomputer Applications Software I	3
CoSci 431	Microcomputer Applications Software II	3
CoSci 450	Electronic Publishing II	3
CoSci 487	Introduction to Local Area Networks	3
ELECTIVES (Choose three [3] courses):		9
CoSci 439	Programming in C	
CoSci 440	Programming in C ++	
CoSci 452	Programming in Java	
CoSci 453	A+ Certification Preparation	

Total 30

Computer Science: Microcomputer Programming Certificate Program Learning Outcomes –

Upon completion, students will be able to:

- Design and write computer programs that are correct, simple, clear, efficient, well organized, and well documented;
- Apply important data structures and algorithms;
- Design and correctly implement to significant computational problems in mathematics and business;
- Demonstrate the ability to reason and think in abstract terms, such as object orientation in order to build proper algorithms.

REQUIRED COURSES

		UNITS
CoSci 401	Introduction to Computers & Their Uses	3
CoSci 407	Programming Logic	3
CoSci 408	Visual Basic	3
CoSci 430	Microcomputer Applications Software I	3
CoSci 431	Microcomputer Applications Software II	3
CoSci 439	Programming in C	3
CoSci 450	Electronic Publishing II	3
CoSci 452	Programming in Java	3
CoSci 487	Introduction to Local Area Networks	3
ELECTIVES (Choose one [1] course):		3
CoSci 436	Introduction to Data Structures	
CoSci 440	Programming in C ++	

Total 30

CERTIFICATES OF ACCOMPLISHMENT

At the completion of the following programs, a Certificate of Accomplishment will be awarded to the student who has completed the course of study with a 3.00 average.

These Certificate of Accomplishment are primarily for those students who have limited time to pursue their formal education and wish to specialize in a particular area of Computer Science that is job-related. They may seek advancement in their present job, or they may



prepare themselves for different or new employment. All courses in the program apply toward a full Certificate and many courses apply toward an Associate Degree.

Computer Science: Microcomputer Applications Certificate of Accomplishment
Program Learning Outcomes –

Upon completion, students will be able to:

- Analyze a problem related to computing requirements and apply the appropriate solution;
- Design, implement and evaluate a computer-based system, process component or program to meet desired needs;
- Demonstrate the ability to address professional, ethical, legal, security and social issues and responsibilities.

REQUIRED COURSES		UNITS
CoSci 401	Introduction to Computers & Their Uses	3
CoSci 430	Microcomputer Applications Software I	3
CoSci 431	Microcomputer Applications Software II	3
CoSci 450	Electronic Publishing II	3
CoSci 487	Introduction to Local Area Networks	3
Total		15

Cyber Security Associate Certificate Of Accomplishment

Program Learning Outcomes –

Upon completion, students will be able to:

- Successfully take the vendor neutral certification exams in A+ +, Network+ and Security+

REQUIRED COURSES		UNITS
CoSci 453	A+ Certification Preparation	3
CoSci 487	Introduction to Local Area Networks	3
Co Sci 411	CyberSecurity I	3
Co Sci 483	Principles of Information Security	3
Co Sci 488	Security+ Certification Preparation	3
Total		15

401 INTRODUCTION TO COMPUTERS & THEIR USES (UC:CSU) 3 UNITS

Prerequisites: None | Lecture 3 hrs, Lab 1 hr
 Describes computer development, uses of the computer by business management, the use of major workplace applications programs, operating systems and programming. Students will analyze, design and construct technology solutions for organizations.

407 PROGRAMMING LOGIC (UC:CSU) 3 UNITS

Prerequisite: Math 115 or 123B or 129B
 Advisory: CoSci 401 | Lecture 3 hrs
 Covers basic concepts of computer hardware, software, and information representation including binary and hexadecimal number systems. Introduces concepts necessary to analyze, design, code, test, and document programs using top-down structured programming techniques. Introduces to programming and fundamental programming concepts using a high level language.

408 VISUAL BASIC (UC:CSU) 3 UNITS

Prerequisite: CoSci 401 | Corequisite: CoSci 407
 Lecture 2 hrs, Lab 2 hrs
 Introductory course in event driven programming using Visual Basic graphical user interfaces for Windows applications programming. Topics include controls and their properties, methods and events; basic data types and variables; subroutines and functions; scope; control structures; building graphical user interfaces; and interfacing with the Windows operating system. Object linking and embedding (OLE) and multimedia also are introduced.

411 CYBER SECURITY I (CSU) 3 UNITS

Advisory: CoSci 431 | Lecture 2 hrs, Lab 2 hrs
 An introduction to the theory and practice of information security. The topics covered include Windows basics, Windows networking, accounts basics, threats, vulnerabilities, and exploits, routes, domain name servers, workgroups, domains, servers, access control, authentication and basic cryptography and design of system defensive strategies.

Disciplines • Educational Programs • Course Descriptions

416 BEGINNING COMPUTER ARCHITECTURE & ORGANIZATION (CSU) 3 UNITS

Prerequisite: CoSci 407

Advisory: CoSci 440 or 452

Lecture 2 hrs, Lab 2 hrs

Covers organization and operation of real computer systems at the assembly-language level. Studies mapping statements and constructs in a high-level language onto sequences of machine instructions as well as the internal representations of simple data types and structures. Investigates basic principles of operating systems and programming language translation process.

430 MICROCOMPUTER APPLICATIONS I (CSU) 3 UNITS

Prerequisite: None

Lecture 2 hrs, Lab 2 hrs

The effective use of Excel and Access. The course includes: financial investment analysis spreadsheets, loan amortization schedules, automatic update of spreadsheets with data downloaded from the Internet, database management and reporting. Recommended for Business Majors.

431 MICROCOMPUTER APPLICATIONS II (CSU) 3 UNITS

Prerequisite: None

Lecture 2 hrs, Lab 2 hrs

Prepare to become MOS certified by taking this class. Students will use Windows and Word to create documents such as cover letters, resumes, term papers, sales proposals, multiple column newsletters and do mail merge operations.

435 MICROCOMPUTER OPERATING SYSTEMS (CSU) 3 UNITS

Prerequisite: CoSci 431

Lecture 2 hrs, Lab 2 hrs

The student will master advanced operating system techniques using a mouse driven/graphical interface. Currently popular microcomputer operating systems programs such as DOS and Windows will be discussed, will be used. Commonly used utility programs will be discussed.

436 INTRODUCTION TO DATA STRUCTURES (UC:CSU) 3 UNITS

Prerequisite: CoSci 440 or 452

Lecture 2 hrs, Lab 2 hrs

Covers abstract data types including a deeper understanding of object-oriented programming concepts. Students will learn how to analyze running times of algorithms using analysis tools. Implements linear data structures including stacks, queues, and hash tables. Introduces to trees and basic implementations.

439 PROGRAMMING IN C (UC:CSU) 3 UNITS

Prerequisite: CoSci 401 and CoSci 407

Lecture 2 hrs, Lab 2 hrs

Focuses on data types, operators and expressions, control flow, functions and program structure, pointers, arrays, arrays of pointers, structures, I/O, and text files. Examples illustrate programming techniques, algorithms, and the use of library routines.

440 PROGRAMMING IN C++ (UC:CSU) 3 UNITS

Prerequisite: Co Sci 439 | Lecture 2 hrs, Lab 2 hrs

Covers C++ language and object-oriented programming paradigm. Fundamental programming topics include control structures, functions, arrays, pointers, strings, input and output, recursion, and file processing. Object-oriented programming and advance topics include classes, operator overloading, inheritance, virtual functions, polymorphism, templates, and exception handling. Introduces to data structures such as stacks, queues, and trees in C++ object oriented programming.

450 ELECTRONIC PUBLISHING II (CSU) 3 UNITS

Prerequisite: None | Lecture 2 hrs, Lab 2 hrs

A beginning course where students will create WEB pages, set up personal or commercial WEB sites, upload to a WEB server that the class creates and use HTML as a foundation to Javascript, Dreamweaver, FLASH, AJAX and other commercial packages.

452 PROGRAMMING IN JAVA (UC:CSU) 3 UNITS

Prerequisite: CoSci 407

Lecture 2 hrs, Lab 2 hrs

Covers Java language and object-oriented programming paradigm. Topics include Java expressions, control structures, methods, Java classes, overloading, object references, inheritance, polymorphism, Java library packages, exception handling, file I/O, applets, GUI, and event handling. Introduces to data structures such as stacks, queues, and trees.

453 A+ CERTIFICATION PREPARATION 3 UNITS

Prerequisite: None | Lecture 2 hrs, Lab 2 hrs
Provides student with the workable knowledge needed for the installation, setup, troubleshooting and optimization of hardware and software related to personal computer systems and peripheral devices. This course will cover information needed to prepare for the current A+ certification test and the CISCO IT certification test.

483 PRINCIPLES OF INFORMATION SECURITY (CSU) 3 UNITS

Prerequisite: CoSci 401 | Lecture 2 hrs, Lab 2 hrs
The principles of information security including new innovations in technology and methodologies. Course includes the historical overview of information security, risk management and security technology (Firewalls and VPNs), current certification information, legal, ethical, and professional issues. Cryptography, physical security, and implementing information security will be covered. Lab exercises allow the students to apply the basics in a hands-on environment.

484 NETWORK SECURITY (CSU) 3 UNITS

Prerequisite: CoSci 487 | Lecture 2 hrs, Lab 2 hrs
Examines the theory of the primary network security threats and the practical application of tools to mitigate those threats. Threats covered will include reconnaissance, access, and denial of services attacks, along with virus, worm and Trojan horse projections. Hardware and software based network protection, including firewalls, access control lists, intrusion detection systems, and cryptography will also be explored along with Virtual Private Networking. This course maps to the commercial Cisco CCNA Security certification.

487 INTRODUCTION TO LOCAL AREA NETWORKS (CSU) 3 UNITS

Advisory: CoSci 453 | Lecture 2 hrs, Lab 2 hrs
Provides a solid foundation in computer networking technology. It covers network cables, connectors & devices, network topologies & architecture, wired and wireless networking protocols & standards, OSI model, TCP/IP, IP addressing, subnets, wide area networks, network security & troubleshooting and client/server operating systems survey.

488 SECURITY + CERTIFICATION PREPARATION (CSU) 3 UNITS

Prerequisite: CoSci 487 | Lecture 2 hrs, Lab 2 hrs
Students learn concepts of computer and network-security and gain skills necessary to apply knowledge of security concepts, tools, and procedures to react to security incidents, and guard against the security risks. At the end of the course students are prepared for the CopmpTIA Security+ certification exam.

185 DIRECTED STUDY (CSU) 1 UNIT

Provides opportunity for in-depth study of a chosen area of Computer Science Information Technology on a contract basis, under the direction of a supervising instructor.

285 DIRECTED STUDY (CSU) 2 UNITS

Provides opportunity for in-depth study of a chosen area of Computer Science Information Technology on a contract basis, under the direction of a supervising instructor.

385 DIRECTED STUDY (CSU) 3 UNITS

Provides opportunity for in-depth study of a chosen area of Computer Science Information Technology on a contract basis, under the direction of a supervising instructor.

COUNSELING

COUNSELING (formerly Personal Development)

FACULTY: Michong Park, Chair | Sherrie Loper, Vice Chair
Diana Bonilla | Aleida Gomez | Christine Kourinian
Afri Walker Tashini Walker | Linda Marie Avalos (EOPS)
Jose Luis Ramirez (EOPS) | Robert Schwartz (DSPS)
Adam Serda (DSPS)

4 CAREER PLANNING (CSU) 1 UNIT

Prerequisite: None | Lecture 1 hr
NOTE: Class is graded pass/no-pass
Designed to assist students in choosing a major or vocational choice. Students will explore their interests, skills, and values through the use of career and vocational assessments. Students will access information regarding occupational characteristics, employment trends and labor market updates.

17 COLLEGE SURVIVAL SKILLS DEVELOPMENT (CSU) 1 UNIT

Prerequisite: None | Lecture 1 hr
NOTE: Class is graded pass/no-pass
Examines a variety of academic survival skills including familiarization with college support services, time management, memory, reading, note-taking, testing techniques, and stress reduction. Included will be identifying different learning, educational, and decision making styles.

22 THE TRANSFER PROCESS (CSU) 1 UNIT

Prerequisite: None | Lecture 1 hr
Introduction to the transfer process. Designed to enable students to become active participants in planning their long-term educational and career goals. Provides students with an understanding of the process and the requirements for transferring to a four-year college or university.

40 COLLEGE SUCCESS SEMINAR (UC:CSU) 3 UNITS

Prerequisite: None | Lecture 3 hrs
Course will explore issues related to higher education that impact student success. Topics will include an overview of academic success skills, value and purpose of higher education, college policies and procedures, ethics and responsibility, educational strategies and planning, interpersonal communication, career development and self-assessment techniques.

Disciplines • Educational Programs • Course Descriptions

CULINARY ARTS PROFESSIONAL STUDIES

FACULTY: Louis Eguaras, Chair
Jesus Sanchez | Jose Silva

EDUCATIONAL PROGRAMS

When enrolled in the Culinary Arts Program at the Culinary Arts Institute at Los Angeles Mission College, there are both the Associate in Arts Degree Program and Certificate programs you can choose from. Most courses at our Culinary Arts Program are acceptable for credit toward a Bachelor's Degree at four-year universities. Completion of either the certificate, Associate in Arts Degree, or transfer program will provide a solid foundation upon which to build a life-long career.

These programs prepare students to enter the culinary arts industry as prep cooks, line cooks, sous chefs, waiters, restaurant managers, and cafe managers. In these positions, employees are required to prepare entrees, create menus, requisition supplies, supervise employees, manage equipment, maintain varied records, coordinate data with accountants and others in the organization, and serve as a liaison between senior management and employees. Always consult an LAMC college counselor for information on graduation requirements.

ASSOCIATE IN ARTS - Culinary Arts

The Culinary Arts AA degree program prepares students for employment in the area of Restaurant/ Food Service Industry and/or to upgrade a position or career within this industry. Additionally this program will serve as a transfer opportunity for students planning on earning a Bachelor's Degree in a four year university. Through this program, students will obtain the necessary skills and competencies for entry-level employment and put them into a position of rapid upward mobility to manager/ supervisor with minimum experience, as well as allow them to earn units transferable to Bachelor's Degree Programs. Specific occupational goals our students expect to acquire include careers as Executive Chef, Sous Chef, Assistant Restaurant Manager, Line Cook, Short Order Cook, Caterer, Personal/ Private Chef, Kitchen Supervisor, Chef Trainer, Butcher, Garde Manger Chef Banquet Chef, Restaurant Chef, Chef De Cuisine, Chef Tournant, Executive Steward, Owner/Operator.

Program Learning Outcomes -

Upon completion, students will be able to:

- Establishing and maintain safety and sanitation procedures
- Prepare standardized recipes using a variety of cooking techniques which meet industry quality standards
- Prepare a variety of American Regional and International recipes utilizing the correct techniques, ingredients and equipment which meet industry quality standards

- Describe and perform tasks related to common business practices in the culinary industry, including inventory, menu planning, cost control, and food purchasing
- Describe the principles of food and beverage management.
- Define and articulate the core values of the culinary professional.
- Seek entry-level positions in commercial and institutional food service settings

REQUIRED COURSES

		UNITS
Cln Art 50	Sanitation & Safety (Formerly FsMgmt 50)	2
Cln Art 60	Culinary Arts Orientation & Techniques (Formerly FsMgmt 100)	4
Cln Art 101	Culinary Fundamentals I (Formerly FsMgmt 101)	4
Cln Art 102	Culinary Fundamentals II (Formerly FsMgmt 102)	4
Cln Art 103	Culinary Nutrition (Formerly Fam&Cs 21)	2
Cln Art 104	Dining Room& Beverage Management (Formerly FsMgmt 104)	4
Cln Art 105	Menu Planning (Formerly FsMgmt 103)	2
Cln Art 106	Purchasing & Receiving (Formerly FsMgmt 105)	3
Cln Art 107	Principles of Garde Manger & Basic Baking	4
Cln Art 108	Restaurant Supervision & Training	2
Cln Art 109	Principles of Catering (Formerly FsMgmt 110)	4
Cln Art 110	Culinary Green Technology	3
Cln Art 150	Chefs Training for Apprenticeship I (Formerly FsMgmt 108)	2
Cln Art 155	Chefs Training for Apprenticeship II (Formerly FsMgmt 108)	2

Total 42

ASSOCIATE IN ARTS - Restaurant Management

The Restaurant Management AA degree program is designed for students preparing for an upwardly mobile career in Restaurant/ Food Service Management. Students learn the basic and advanced methods and techniques for managing a restaurant or other food service operation such as, Menu Planning, Purchasing & Receiving, Quality Food Production Standards, Quality Beverage Management Standards, Facilitating Performance of Production Staff, Managing Buffets, Banquets and Catered Events, Food & Beverage Analysis and Decision Making, Organization and Management Theory, and Small Business Entrepreneurship. Additionally this program serves to enable students to earn units transferable to more advanced schools. This provides opportunities for students planning on earning a Bachelor's Degree in a four year University.

Program Learning Outcomes –

Upon completion, students will be able to:

- Demonstrate station organization, purchasing, storage, menu writing, and sanitation principles as they apply to food handling
- Use classic cooking terminology and methods, apply health and safety standards
- Demonstrate skill and apply professional industry standards in food handling, dining room & beverage service, baking and food service, and use of kitchen equipment and tools
- Demonstrate responsibility and team skills for the food service industry
- Describe career opportunities within the food industry and strategize own career
- Critique, assess and improve one's own performance, listening skills and communication
- Skills for personal, academic and career purposes
- Recognize the diversity of cultural influences and values related to a professional culinary environment
- Think critically in evaluating information, solving problems, and making decisions related to food preparation and food service

REQUIRED COURSES

CA 50	Sanitation & Safety
CA 60	Culinary Arts Orientation & Techniques
CA 101	Culinary Fundamentals I
CA 103	Culinary Nutrition
CA 104	Dining Room& Beverage Management
CA 105	Menu Planning
CA 106	Purchasing & Receiving
CA 107	Principles of Garde Manger & Basic Baking
CA 108	Restaurant Supervision & Training
CA 109	Principles of Catering
CA 155	Chefs Training for Apprenticeship II
Mgmt 2	Organization & Management Theory
Mgmt 13	Small Business Entrepreneurship
Bus 5	Business Law

UNITS	• Use classic cooking terminology and methods, apply health and safety standards
2	
4	• Demonstrate skill and apply professional industry standards in food handling, dining room & beverage service, baking and food service, and use of kitchen equipment and tools
4	
2	• Demonstrate responsibility and team skills for the food service industry
2	
3	• Describe career opportunities within the food industry and strategize own career
4	
2	• Critique, assess and improve one's own performance, listening skills and communication skills for personal, academic, and career purposes
4	
2	• Recognize the diversity of cultural influences and values related to a professional culinary environment
3	
3	• Think critically in evaluating information, solving problems, and making decisions related to food preparation and food service.
3	
Total 42	

CERTIFICATE OF ACHIEVEMENT - Culinary Arts

The program is designed to train and prepare students for careers in all aspects of the culinary arts and hospitality fields. The design of the program is balanced between developing the culinary tactile skills of food preparation and the management qualities necessary for career growth. Successful students will be prepared to work as prep cooks, line cooks, sous chefs, and kitchen managers, restaurant managers in a wide range of food service settings, such as restaurants, hotels, catering operations, and institutional kitchens. The program will focus on cooking skills development, problem solving, supervision, kitchen management skills and challenging students to critically evaluate the strengths and weaknesses of culinary operations and identify entrepreneurial approaches to restaurant operations.

Program Learning Outcomes –

Upon completion, students will be able to:

- Demonstrate station organization, purchasing, storage, menu writing, and sanitation principles as they apply to food handling

REQUIRED COURSES

Cln Art 50	Sanitation & Safety (Formerly FsMgmt 50)	UNITS	2
Cln Art 60	Culinary Arts Orientation & Techniques (Formerly FsMgmt 100)		4
Cln Art 101	Culinary Fundamentals I (Formerly FsMgmt 101)		4
Cln Art 102	Culinary Fundamentals II (Formerly FsMgmt 102)		4
Cln Art 103	Culinary Nutrition (Formerly Fam&Cs 21)		2
Cln Art 104	Dining Room& Beverage Management (Formerly FsMgmt 104)		4
Cln Art 105	Menu Planning (Formerly FsMgmt 103)		2
Cln Art 106	Purchasing & Receiving (Formerly FsMgmt 105)		3
Cln Art 108	Restaurant Supervision & Training		2
Cln Art 150	Chefs Training for Apprenticeship I (Formerly FsMgmt 108)		2
Mgmt 2	Organization & Management Theory		3
		Total	32

Recommended Courses

Cln Art 109	Principles of Catering (Formerly FsMgmt 110)	4
Cln Art 110	Culinary Green Technology	3
Market 22	Green Marketing	3

Disciplines • Educational Programs • Course Descriptions

CERTIFICATE OF ACHIEVEMENT - Professional Baking & Patisserie

The Baking & Patisserie Certificate of Achievement program is designed for students preparing for an upwardly mobile career in Baking & Patisserie industry. The Baking & Patisserie Certificate of Achievement program prepares students for entry-level employment in bakeries, pastry shops, hotels and fine dining restaurants. Through this program, students will obtain the necessary skills and competencies for entry-level employment and put them into a position of rapid upward mobility to manager/supervisor with minimum experience. Specific occupational goals our students expect to acquire include careers as Baking Prep Cook, Pastry Cook, Lead Baker, Assistant Pastry Chef, Executive Pastry Chef, and Bake Shop or Pastry Shop Owner/Operator.



Program Learning Outcomes -

Upon completion, students will be able to:

- Define and use the basic terminology and techniques of the professional baker and pastry chef;
- Demonstrate proficiency in advanced techniques for specific baking & pastry applications;
- Demonstrate the importance of local and seasonal products in professional baking;
- Demonstrate station organization, purchasing, storage, menu writing, and sanitation principles as they apply to food handling;
- Demonstrate responsibility and team skills for the food service industry;
- Determine and appraise career opportunities within the baking industry;
- Critique, assess, and improve performance, listening and communication skills; and
- Employ the diversity of cultural influences and values related to a professional baking environment.

REQUIRED COURSES

		UNITS
Cln Art 50	Sanitation & Safety (Formerly FsMgmt 50)	2
Cln Art 60	Culinary Arts Orientation & Techniques (Formerly FsMgmt 100)	4
Cln Art 103	Culinary Nutrition (Formerly Fam&Cs 21)	2
Cln Art 107	Principles of Garde Manger & Basic Baking	4
Cln Art 108	Restaurant Supervision & Training	2
Cln Art 150	Chefs Training for Apprenticeship I	2
Cln Art 155	Chefs Training for Apprenticeship II (Formerly FsMgmt 108)	2
ProfBkg 200	Principles of Baking & Patisserie I	4
ProfBkg 210	Principles of Baking & Patisserie II	4
ProfBkg 215	Restaurant Plated Desserts	4

Total 30

Recommended Courses

Cln Art 109	Principles of Catering (Formerly FsMgmt 110)	4
Cln Art 110	Culinary Green Technology	3
Market 22	Green Marketing	3

Restaurant Management Certificate of Achievement

The certificate program is designed to train and prepare students for careers in all aspects of the culinary arts and hospitality fields. The design of the program is balanced between developing the culinary tactile skills of food preparation and the management qualities necessary for career growth. Successful students will be prepared to work as prep cooks, line cooks, sous chefs, and kitchen managers in a wide range of food service setting, such as restaurants, hotels, catering operations, and institutional kitchens. The program will focus on cooking skills development, problem solving, supervision, kitchen management skills and challenging students to critically evaluate the strengths and weaknesses of culinary operations and identify entrepreneurial approaches to restaurant operations.

Program Learning Outcomes -

Upon completion, students will be able to:

- Demonstrate station organization, purchasing, storage, menu writing, and sanitation principles as they apply to food handling;
- Use classic cooking terminology and methods, apply health and safety standards;
- Demonstrate skill and apply professional industry standards in food handling, dining room & beverage service, baking and food service, and use of kitchen equipment and tools;
- Demonstrate responsibility and team skills for the food service industry;
- Describe career opportunities within the food industry and strategize own career;
- Critique, assess and improve one's own performance, listening skills and communication;
- Skills for personal, academic and career purposes;
- Recognize the diversity of cultural influences and values related to a professional culinary environment;
- Think critically in evaluating information, solving problems, and making decisions related to food preparation and food service.

REQUIRED COURSES		UNITS
ClnArt 50	Sanitation & Safety <i>(formerly FSMgmt 50)</i>	2
ClnArt 60	Culinary Arts Orientation & Techniques <i>(formerly FSMgmt 100)</i>	4
ClnArt 101	Culinary Fundamentals I <i>(formerly FSMgmt 101)</i>	4
ClnArt 103	Culinary Nutrition <i>(formerly Fam&CS 21)</i>	2
ClnArt 104	Dining Room & Beverage Management <i>(formerly FSMgmt 104)</i>	4
ClnArt 105	Menu Planning <i>(formerly FSMgmt 103)</i>	2
ClnArt 106	Purchasing & Receiving <i>(formerly FSMgmt 105)</i>	3
ClnArt 107	Principles of Garde Manger & Basic Baking	4
ClnArt 108	Restaurant Supervision & Training	2
ClnArt 109	Principles of Catering <i>(formerly FSMgmt 110)</i>	4
ClnArt 155	Chefs Training for Apprenticeship II <i>(formerly FSMgmt 108)</i>	2
Mgmt 2	Organization & Management Theory	3
Mgmt 13	Small Business Entrepreneurship	3
Bus 5	Business Law I	3
Total 42		

CERTIFICATES OF ACCOMPLISHMENT

The student will be given a Certificate of Accomplishment following the completion of any of the following programs if the student has maintained a minimum of a C grade in all required courses. Certificates of Accomplishment are for students who have limited time and wish to limit their commitment but desire an increased level of specialization. Always consult a counselor for information on graduation requirements and transfer information.

Program Learning Outcomes –

Upon completion, students will be able to:

- Apply for entry-level employment in the Culinary Arts industry. Through this program, students will obtain the necessary skills and competencies for entry-level positions such as Dishwasher, Line Cook, and Short Order Cook. These positions are the foundation of every successful operation.

Baking Specialist I Certificate of Accomplishment

REQUIRED COURSES		UNITS
ClnArt 50	Sanitation & Safety <i>(formerly FSMgmt 50)</i>	2
ClnArt 60	Culinary Arts Orientation & Techniques <i>(formerly FSMgmt 100)</i>	4
ClnArt 103	Culinary Nutrition <i>(formerly Fam&CS 21)</i>	2
ProfBkg 200	Principles of Baking & Patisserie I <i>(formerly FSMgmt 100)</i>	4
Total 12		

Baking Specialist II Certificate of Accomplishment

Program Learning Outcomes –

Upon completion, students will be able to:

- Establish and maintain high standards of sanitation and food safety as established by the SERVSAFE program.
- Produce various baked goods and a variety of international and classical pastries and desserts using basic and advanced techniques.
- Prepare standardized recipes using a variety of cooking, baking, and pastry techniques as well as equipment and tools.
- Ability to calculate food costs from recipes.
- Communicate clearly and professionally, both verbally and in writing.
- Demonstrate proficiency in basic terminology and techniques for baking and patisserie to include food preparation and presentation.

REQUIRED COURSES		UNITS
Cln Art 107	Principles of Garde Manger & Basic Baking	4
Cln Art 108	Restaurant Supervision & Training	2
Cln Art 150	Chefs Training for Apprenticeship I <i>(Formerly Fsmgmt 108)</i>	2
ProfBkng 210	Principles of Baking & Patisserie II	4
Total 12		



Culinary Specialist I Certificate of Accomplishment

Program Learning Outcomes –

Upon completion, students will be able to:

- Apply for entry level to middle management employment in the Culinary Arts industry. Through this program, students will obtain the necessary skills and competencies for front-of-the-house positions such as Lead Waitstaff, Assistant Restaurant Manager, and Maitre D'Hotel in Training.

REQUIRED COURSES		UNITS
ClnArt 50	Sanitation & Safety <i>(formerly FSMgmt 50)</i>	2
ClnArt 60	Culinary Arts Orientation & Techniques <i>(formerly FSMgmt 100)</i>	4
ClnArt 101	Culinary Fundamentals I <i>(formerly FSMgmt 101)</i>	4
ClnArt 103	Culinary Nutrition <i>(formerly Fam&CS 21)</i>	2
Total 12		

Disciplines • Educational Programs • Course Descriptions

Culinary Specialist II Certificate of Accomplishment

Program Learning Outcomes –

Upon completion, students will be able to:

- Use discipline specific terminology in oral and written communication.
- Describe and perform tasks related to common business practices in the culinary industry, including inventory, menu planning, cost control, and food purchasing.
- Prepare standardized recipes using a variety of cooking techniques which meet industry quality standards.
- Establish and maintain high standards of safety and sanitation procedures.
- Identify and demonstrate the concepts of recipe costing, purchasing, receiving, and issuing practices in food service operations.
- Develop strategies to improve business performance using creativity and problem solving skills based on operational theory and procedures.

REQUIRED COURSES	UNITS
Cln Art 102 Culinary Fundamentals II (<i>Formerly FsMgmt 102</i>)	4
Cln Art 105 Menu Planning (<i>Formerly FsMgmt 103</i>)	2
Cln Art 106 Purchasing & Receiving (<i>Formerly FsMgmt 105</i>)	3
Cln Art 108 Restaurant Supervision & Training	2
Cln Art 150 Chefs Training for Apprenticeship I (<i>Formerly FsMgmt 108</i>)	2
Total	13

Restaurant Management Certificate of Accomplishment

Program Learning Outcomes –

Upon completion, students will be able to:

- Apply for entry level employment in the Baking & Patisserie industry. Through this program, students will obtain the necessary skills and competencies for positions such as Junior Baker, Assistant Cake Decorator, and Junior Pastry Cook.

REQUIRED COURSES	UNITS
ClnArt 104* Dining Room & Beverage Management (<i>formerly FSMgmt 104</i>)	4
ClnArt 108* Restaurant Supervision & Training	2
ClnArt 150* Chefs Training for Apprenticeship I (<i>formerly FSMgmt 108</i>)	2
Mgmt 2 Organization & Management Theory	3
Mgmt 13 Small Business Management	3
Total	14

*Check catalog for additional prerequisites

50 SANITATION & SAFETY (CSU) 2 UNITS

Prerequisite: None | Lecture 2 hrs
(*formerly FSMgmt 50*)

An introduction to the basic principles of sanitation, safety, work simplification, and use and care of institutional food service equipment. Emphasis is on the importance of proper employee training practices as related to food safety. ServSafe Food Handler's Manager Certification will be obtained upon successfully passing exam.

60 CULINARY ARTS ORIENTATION & TECHNIQUES (CSU) 4 UNITS

Corequisite: ClnArt 50 or FSM 50

Lecture 2 hrs, Lab 6 hrs

(*formerly FSMgmt 100*)

Students will apply history, description, and interrelationships of the hospitality industries with an emphasis on the multifaceted food service industry. Introduction to the world of commercial food production. Students are introduced to culinary theories and develop skills in knife handling, fabrication skills, ingredient identification, small and large equipment use, weights and measures, recipe development and cooking fundamentals.

101 CULINARY FUNDAMENTALS I (CSU) 4 UNITS

Corequisite: ClnArt 60 or FSMgmt 50 & 100

Lecture 2 hrs, Lab 6 hrs

(*formerly FSMgmt 101*)

Introduction to culinary fundamentals and techniques for basic food preparation is learned and experienced. Culinary arts basics and foundations, including classic knife cuts, mother sauces, soups, basic cooking methods, terminology, equipment, measurements, culinary math and ingredients are covered. Students will be on rotation in the Mission Cafe/Servery to enhance their experience in a real environment setting.

102 CULINARY FUNDAMENTALS II (CSU) 4 UNITS

Prerequisite: ClnArt 101 or FSMgmt 50, 100, 101

Lecture 2 hrs, Lab 6 hrs

(*formerly FSMgmt 102*)

Introduction to breakfast and lunch cookery. Students will prepare breakfast and lunch items. Students will be part of a rotation in the Mission Cafe (AKA The Servery) and rotate all throughout the stations in the cafe. Student will cover culinary management, supervision, leadership, customer service, communication, teamwork and time management.

103 CULINARY NUTRITION (CSU) 2 UNITS
Prerequisite: None | Lecture 2 hrs
(formerly *Fam&CS 21*)

Fundamental culinary nutrition principles and theories for various groups are investigated. Healthy foods, pleasing to the eyes and the palate, will be prepared to cater to the growing number of health-minded customers. Recipe and menu development including ingredient selection and cooking techniques will be discussed. Special diets such as low fat, low sodium, diabetic, gluten-free and caloric intake will be discussed.

104 DINING ROOM & BEVERAGE MANAGEMENT (CSU) 4 UNITS
Prerequisite: Cln Art 101 or FsMgmt 50, 100 & 101
Lecture 2 hrs, Lab 6 hrs
(formerly *FSMgmt 104*)

Instruction and practical training covers all aspects of FOH/Dining Room service and Beverage Management in restaurants. This includes food and cash controls, POS systems, dining room service styles and dining area merchandising. Receptions, banquets, buffets are covered from the busperson to Maitre d' positions. Special event presentations included with wine serving techniques.

105 MENU PLANNING 2 UNITS
Prerequisite: ClnArt 101 or FSMgmt 50, 100, 101
Lecture 2 hrs
(formerly *FSMgmt 103*)

Examines the fundamentals of menu planning using the menu as a tool for ordering, selection and procurement of food and beverage items. Menu, labor, and facility computer generated cost analysis and percentages will be addressed. Emphasis is placed on developing the skills necessary to effectively create a professional menu. Provides training in duties and functions of the professional food buyer working in purchasing capacity.

106 PURCHASING & RECEIVING (CSU) 3 UNITS
Prerequisite: ClnArt 101 or FSMgmt 50, 100, 101
Lecture 2 hrs, Lab 2 hrs
(formerly *FSMgmt 105*)

Provides training in duties and functions of the professional food buyer. Basic information on sources, grades, quality, and standards for selecting food items. Points stressed are specifications for: receiving, storing, issuing procedures, cost and operational expenses, and seasonal variations.

107 PRINCIPLES OF GARDE MANGER & BASIC BAKING (CSU) 4 UNITS
Prerequisite: Cln Art 101 or ProfBkg 200
Lecture 2 hrs, Lab 6 hrs

A comprehensive study of Garde Manger and Basic Baking Techniques. This includes the study and preparation of classic and contemporary salads; dressings, appetizers; canapes; vegetable/fruit carvings and salt/ice carvings. Foundational basic baking techniques are covered.

108 RESTAURANT SUPERVISION & TRAINING (CSU) 2 UNITS
Prerequisite: Cln Art 101 or ProfBkg 200
Lecture 2 hrs

Students are introduced to human resource management and supervision techniques. Students will identify the recruiting process, communication skills, leadership styles, legal issues in the workforce, employee motivation and discipline. This course includes problem solving in food service operations and procedures for developing personnel programs and effective labor management relationships.

109 PRINCIPLES OF CATERING (CSU) 4 UNITS
Prerequisite: ClnArt 101 or FSMgmt 50, 100, 101
Lecture 2 hrs, Lab 4 hrs
(formerly *FSMgmt 110*)

The study of catering sales and operations, including 'hands on' practicum and interpersonal dynamics from production through a catering service. Topics covered include the preparation of a menu, estimating cost and food quantities, planning the room arrangement, the setup of buffet and service tables, and the performance of services. In addition, the allocation of time to prepare, transport, and setup the equipment and food for a catered event are studied.

110 CULINARY GREEN TECHNOLOGY (CSU) 3 UNITS
Prerequisite: Cln Art101 or FsMgmt 50, 100 & 101
Lecture 2 hrs, Lab 2 hrs

Procurement, identification and quality standards of vegetables, fruits, and herbs utilized in a restaurant or culinary setting. Integration of seasonality, grading, post-harvest handling and environmental impacts. Emphasis is on care, watering, fertilizer and weed control of the Organic Herb & Farm Garden by the Culinary Arts Institute and making sure that all products used in the Culinary Arts Institute building. Follows green standards as described by LEED Platinum Certification.

Disciplines • Educational Programs • Course Descriptions

150 CHEFS TRAINING FOR APPRENTICESHIP I (CSU) 2 UNITS

Prerequisite: ClnArt 101 or FSMgmt 50, 100, 101
Lecture 1 hr, Lab 3 hrs
(formerly FSMgmt 108)

Provides supervised internship experience within the Culinary Arts Institute. Internship provides students with hands-on training and experience in working on the line in The Mission Cafe (AKA The Servery), customer service, catering, special events and prepares them for their externship experience. Students learn skills required for commercial, restaurant and hotel establishments.

155 CHEFS TRAINING FOR APPRENTICESHIP II (CSU) 2 UNITS

Prerequisite: Cln Art101 or ProfBkg 200
Lecture 1 hr, Lab 3 hrs
(formerly FSMgmt 108)

Provides supervised externship opportunity within a selected outside restaurant, hotel or food service establishment who supports the Culinary Arts Institute program. This is a supervised fieldwork experience in the industry and gives hands-on training in food service, catering, fine dining, commercial service, hotel and restaurant establishments. Students learn skills required for job competence.

160 WORLD VITICULTURE & WINE STYLES (CSU) 3 UNITS

Prerequisite: None | Lecture 3 hrs

Survey of world viticulture and wine industries. Course includes history of viticulture; grapevine anatomy; worldwide grape, raisin and wine production and consumption; and world wine regions. Pregnant women and persons with allergies to sulfites are advised not to take this class. Required course for the Wine Studies sequential program leading to Level 1 Certification under the Court of Master Sommeliers. Must be 21 years of age to participate in wine tasting.

161 INTRO TO WINE IN (UC/CSU) 3 UNITS



THE RESTAURANT

Prerequisite: None | Lecture 3 hrs

An introduction to the process and science of winemaking, including history, with an emphasis on the California industry. Examines the management of wine purchasing, storage, and selling for the culinary arts or restaurant management professional. Pregnant women and persons with allergies to sulfites are advised not to take this class. Required course for the Wine Studies sequential program leading to Level 1 Certification under the Court of Master Sommeliers. Must be 21 years of age to participate in wine tasting.

162 WINES OF CALIFORNIA (CSU) 2 UNITS

Prerequisite: None | Lecture 2 hrs

Explores the major wine regions of California including the grape varieties and types of wine production. Includes the wine styles and associated wine laws, structure and culture of California. Pregnant women and persons with allergies to sulfites are advised not to take this class. Required course for the Wine Studies sequential program leading to Level 1 Certification under the Court of Master Sommeliers. Must be 21 years of age to participate in wine tasting.

163 WINES OF FRANCE (UC/CSU) 2 UNITS

Prerequisite: None | Lecture 2 hrs

Explores the major wine regions of France, the grape varieties and wine production. Includes the wine styles and associated wine laws, structure and culture of France. Pregnant women and persons with allergies to sulfites are advised not to take this class. Required course for the Wine Studies sequential program leading to Level 1 Certification under the Court of Master Sommeliers. Must be 21 years of age to participate in wine tasting.

DANCE STUDIES

HEALTH / KINESIOLOGY / ATHLETICS

FACULTY: Leslie Milke, Chair

805 HISTORY & APPRECIATION OF DANCE (UC:CSU) 3 UNIT

Prerequisite: None | Lecture 3 hrs

Course will examine the historical evolution of dance throughout western society in the forms of court dance, ballet, modern dance, musical theater, dance theater, tap, jazz, social dance and ballroom dance. Will consider the impact of dance on the western world and some other cultures and how it has been affected by the different dance traditions world-wide and how the historical evolution, culture and social events, political, and philosophical climate of the period reflects on dance and its evolution.

DANCE TECHNIQUES

HEALTH / KINESIOLOGY / ATHLETICS

FACULTY: Leslie Milke, Chair

121 JAZZ DANCE TECHNIQUES I (CSU) 1 UNIT

Prerequisite: None | Lab 3 hrs

This fundamental course in Jazz dance provides a foundation for performance-based dance techniques of Jazz by introducing fundamental step sequencing and combinations, music, terminology and appreciation of the evolution of Jazz dance as a performing art form, which prepares students for further study in Jazz dance technique.

122 JAZZ DANCE TECHNIQUES II (CSU) 1 UNIT

Prerequisite: DanceTq 121 | Lab 3 hrs

This beginning level Jazz dance course continues to establish basic knowledge of performance-based Jazz dance technique by utilizing compound step sequences and combinations, higher codified level terminology, diverse selections of musical rhythms and phrasing and affirms each student's appreciation of the evolution of Jazz dance as a performing art form by reviewing cumulative jazz technique and information while preparing students for further study at higher levels.

141 MODERN DANCE TECHNIQUES 1 (CSU) 1 UNIT

Prerequisite: None | Lab 3 hrs

Teaches technique, principles, terminology and the practice of modern contemporary dance at the introductory level. Students will undergo an in depth exploration of how the body is used in modern dance technique with a focus on alignment, body part initiation, body organization and sequencing. The course will also include the history of modern dance and an introduction to the elements of space, time, and energy through improvisational and choreographic exercises. Students will develop coordination, flexibility, and cardiovascular strength using various movement combinations.

142 MODERN DANCE TECHNIQUES 2 (CSU) 1 UNIT

Prerequisite: DanceTq 141 | Lab 3 hrs

Teaches technique, principles, terminology and the practice of modern (contemporary) dance at the beginning level. Emphasis is on the correct placement and execution of beginning level modern dance movements, and will include an in-depth exploration of the choreographic element of space through improvisational and choreographic exercises. Students will develop coordination, flexibility, and cardiovascular strength using various movement combinations.

462 MODERN DANCE (UC:CSU) 1 UNIT

Prerequisite: None | Lab 3 hrs

Focuses on the development of dance skills through modern dance movement, emphasizing combinations on the floor and standing or traveling through space. Includes the historical development of modern dance. Students will develop coordination, muscular strength and endurance, flexibility and low intensity cardiovascular endurance by practicing choreographed dance movement exercises.



Disciplines • Educational Programs • Course Descriptions

DEVELOPMENTAL COMMUNICATIONS

ESL / DEVCOM / LEARNING SKILLS

FACULTY: Gary Prostack, Chair
Curt Riesberg, Vice Chair

ESL, English and Developmental Communication Course Sequence

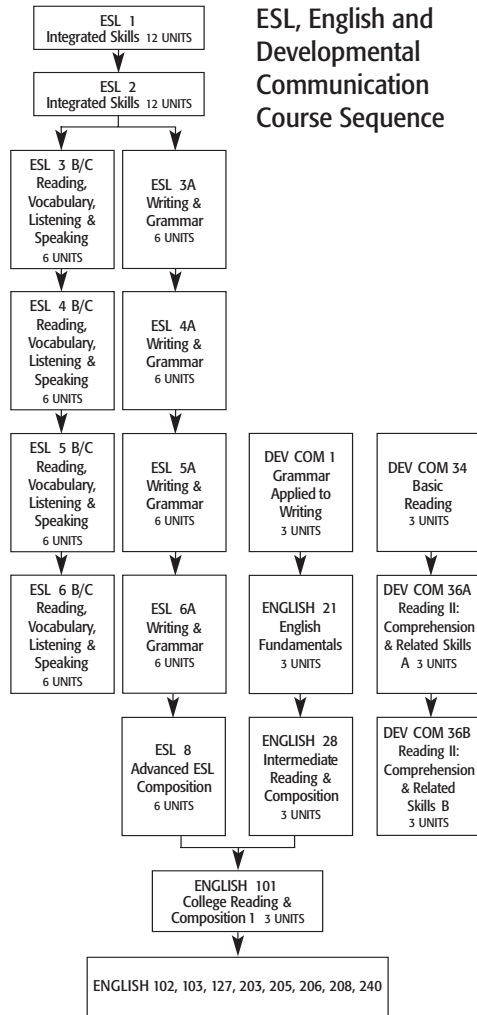

1 GRAMMAR: APPLIED TO WRITING (NDA) 3 UNITS

Prerequisite: Placement Exam | Lecture 3 hrs

NOTE: Class graded pass/no-pass

Offers an introduction to basic grammar as it relates to writing and other communication skills. Reviews parts of speech, sentence structure, types of phrases and clauses, verb tenses and agreement, pronoun usage, comparison, capitalization, and punctuation.

34 BASIC READING (NDA) 3 UNITS

Prerequisite: Placement Exam | Lecture 3 hrs

NOTE: Class graded pass/no-pass

A basic reading course designed to improve word-attack skills, build vocabulary, improve dictionary skills, and develop comprehension and critical reading skills.

36 READING II: COMPREHENSION & RELATED SKILLS (NDA) 6 UNITS

Prerequisite: DevCom 34 or appropriate skill level demonstrated by placement exam

Lecture 6 hrs

NOTE: Class graded pass/no-pass

36A - Intermediate course in reading; emphasizes finding main ideas, critical thinking, vocabulary skills, and study skills.

36B - Comprehensive course in advanced study skills, note-taking, and efficient study techniques. Transition from everyday reading skills to college reading skills.

EARTH SCIENCE LIFE SCIENCES

FACULTY: J. Michael Reynolds, Chair

1 EARTH SCIENCE 3 UNITS

Prerequisite: None | Lecture 3 hrs

Course surveys the science of whole Earth inquiry and thereby includes the following topics: Scientific method, Earth systems, Earth materials, internal processes, surface processes, oceans, atmosphere, Earth origins, and Earth history with special attention to the cycling of elements within the organizing paradigms of contributory disciplines such as Plate Tectonic Theory, the Theory of Evolution, and the Big Bang.

2 EARTH SCIENCE LABORATORY 2 UNITS

Corequisite: Earth 1 | Lecture 1 hr, Lab 2 hrs

Earth Science Laboratory supplements Earth Science Lecture. Students are introduced to the study of Earth materials by learning to identify common minerals and rocks. Interpretations of processes acting on and within the Earth are approached through the study of information contained in maps, aerial photographs, and data sets collected from a variety of Earth-sensing instruments.

ECONOMICS

BUSINESS / LAW

FACULTY: Vilma Bernal, Chair

AMERICAN HISTORY INSTITUTIONS TRANSFER REQUIREMENT

If you took a U.S. history course outside of California, make certain you meet the California State and local government transfer requirements to the California State Universities as listed below. Please consult with a counselor or a history instructor.

U.S.-1 History – History 11, 12, AfroAm 4, Chicano 8, Econ 10

U.S.-2 Constitution – PolSci 1

U.S.-3 State and local government – PolSci 1

1 PRINCIPLES OF ECONOMICS I (UC:CSU) 3 UNITS
Prerequisite: Math 115 or 123B or 129B
Lecture 3 hrs

Introductory course in the principles of microeconomic theory, including economic analysis of the firm and resource allocation; analysis of the laws of supply and demand; market structures of the American economy; price theory; current domestic economic issues.

2 PRINCIPLES OF ECONOMICS II (UC:CSU) 3 UNITS
Prerequisite: Math 115 or 123B or 129B
Lecture 3 hrs

Introductory course in the principles of macroeconomic theory. Measurement of aggregate economic performance, including GNP and national income, money and banking business cycle, role of government and the Federal Reserve System (fiscal and monetary policies), economic growth and stability, international trade, and economics of under development are covered in this course.

10 ECONOMIC HISTORY OF THE UNITED STATES (UC:CSU) 3 UNITS

Prerequisite: None | Lecture 3 hrs

Historical development of the United States: its origins, modification and performance. The relationship to political economics and history in the US. Technology, ethnic groups, major social/economic groups and geographic development as they influence the economic history of the U.S. The social changes, social movements, internal and external relationships of the United States.

EDUCATION

CHILD & FAMILY STUDIES

FACULTY: Janice Silver, Chair

EDUCATIONAL PROGRAMS

Associate in Arts for Transfer (AA-T) Elementary Teacher Education

The Associates of Arts for Transfer (AA-T) in Elementary Teacher Education is designed for prospective California State University (CSU) transfer students who are preparing for careers as Elementary School Teachers. Completion of the Elementary Teacher Education degree will provide a streamlined pathway for transfer to a CSU campus with a Liberal Studies or similar major.

Program Learning Outcomes –

Upon completion, students will be able to:

- Create lesson plans that conform to State Content Standards for California Public Schools and be related to the National Standards.
- Transfer to CSU campuses that offer bachelor's degrees in Liberal Studies or Integrated Teacher Education Programs.

REQUIRED CORE

Bio 3	Intro to Biology	4
Ch Dev 1	Child Growth & Development	3
Comm 101	Oral Communication I	3
Earth 1	Earth Science I	3
Earth 2	Earth Science Laboratory	2
Educ 1	Intro to Teaching	3
English 101	College Reading and Composition I	3
English 102	College Reading and Composition II	3
Math 215	Principles of Mathematics I	3
Geo 7	World Regional Geography	3
His 11	The Government of the United State	3
His 86	Introduction to World Civilization I	3
PolSci 1	The Government of the United States	3

Select one (1) course with a lab:

Chem 51	Fundamentals of Chemistry I	4-5
or Chem 65	Intro to General Chemistry I	
or Phys Sc 1	Physical Sciences I	
and Phys Sc 14	Physical Sciences Laboratory	

LIST A: Select one (1) course

English 102	College Reading and Composition 2	3
or English 103	Composition and Critical Thinking	

LIST B: Select one (1) course

Art 103	Art Appreciation I	3
Music 111	Music Appreciation I	
Thtr 100	Intro to Theater	

LIST C: Select additional units from the following as needed:

Ch Dev 45	Programs for Children with Special Needs
Educ 203	Education in American Society
or Any LIST A or LIST B course not already used	

Total 49-56

NOTE: A minimum of 60 units and a cumulative GPA of 2.0 or higher must be completed to earn the Associate in Arts for Transfer. Always consult a counselor for information on graduation requirements, residency requirements and transfer information.

Disciplines • Educational Programs • Course Descriptions

1 INTRODUCTION TO TEACHING 3 UNITS

Advisories: English 28 | Lecture 3 hrs

This course introduces students to the field of professional education and the concepts and issues that are related to K-12 education. Topics of this course include a basic understanding of a teacher's role and challenges in society, contemporary education issues within historical, social, philosophical, legal, and political contexts, impact of government policies on schools and children, and the various perspectives on curriculum and instruction.

6 METHODS & MATERIALS OF TUTORING 1 UNIT

Prerequisite: None | Lecture 1 hr

NOTE: Class graded pass/no-pass

This class trains new tutors in theory and practice in tutoring techniques, group dynamics, interpersonal skills, and record-keeping. Tutors will be trained to work with self-instructional materials and will tutor students enrolled in supervised learning assistance and/or other college approved tutoring programs.

203 URBAN EDUCATION IN AMERICAN SOCIETY (UC:CSU) 3 UNITS

Prerequisite: None | Lecture 3 hrs

Introduces the American educational enterprise, especially problems in urban multicultural schools. Employs concepts and methods from sociology, philosophy and the politics of education to analyze American schools. Includes K-12 content standards, Teaching Performance Expectations. Requires a minimum of 30 hours of observation/participation in a multicultural school.

ENGLISH ENGLISH / COMMUNICATION STUDIES

FACULTY: Dr. Louise Barbato, Chair
Dr. Carolyn Daly, Vice-Chair
Veronica Diaz-Cooper, Vice-Chair | Gina Ladinsky

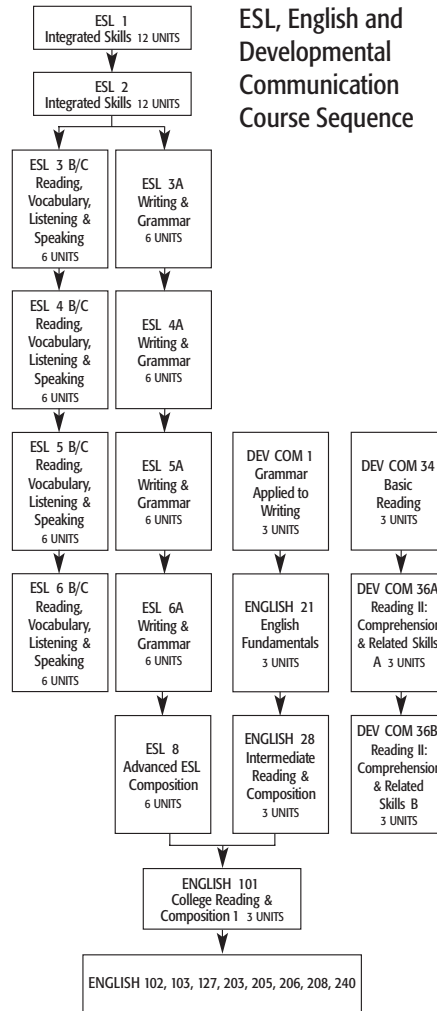

EDUCATIONAL PROGRAM

ASSOCIATE IN ARTS - English

For General Education Requirements, see page 73
An English degree is appropriate for all students who want to improve written and oral expression. It also affords you the opportunity to expand your comprehension of diverse literary texts. This degree is advantageous for students who are interested in teaching as well as those who plan to continue with graduate work in programs ranging from liberal arts to law. Consider the English major alone or as a double major with another field of study such as business. An Associate in Arts English degree will transfer to most UCs and CSUs.

NOTE: A minimum of 60 units and a cumulative GPA of 2.0 or higher must be completed to earn the Associate in Arts Degree. Always consult a counselor for information on graduation requirements, residency requirements and transfer information.

Program Learning Outcomes -

Upon completion, students will be able to:

- Analyze written text to identify underlying logic and point of view;
- Develop a well-organized paper which develops cogent main ideas stated in a thesis and which has adequate support for statements made;
- Utilize diverse sources of information, to research a topic;
- Attribute quotes and other information gleaned from print and electronic sources, according to MLA style;
- Evaluate arguments for validity, objectivity and soundness;
- Argue a point after having gathered and synthesized relevant information, data and evidence;
- Critique text in terms of style and relate a text to the period in which it was written;

- Distinguish fallacies in arguments and be able to recognize the validity or lack of validity of various points of view.

REQUIRED COURSES		UNITS
English 101	College Reading & Composition I	3
English 102	College Reading & Composition II	3
English 205	English Literature I	3
English 206	English Literature II	3
English 208	American Literature II	3
At least one (1) course from the following:		3
English 127	Creative Writing	
English 203	World Literature I	
English 240	Literature & the Motion Picture	

Total 18

RECOMMENDED COURSE		
English 103	Composition & Critical Thinking	3

Associate in Arts for Transfer (AA-T) English

An English degree is appropriate for all students who want to improve written and oral expression. It also affords students the opportunity to expand their comprehension of diverse literary texts. This degree is not only for students who are interested in teaching, but it is also for students who plan to continue with graduate work in programs ranging from liberal arts to law.

Program Learning Outcomes –

Upon completion, students will be able to:

- Analyze written text to identify underlying logic and point of view;
- Develop a well-organized paper which develops cogent main ideas stated in a thesis and which has adequate support for statements made;
- Utilize diverse sources of information, to research a topic;
- Attribute quotes and other information gleaned from print and electronic sources, according to MLA style;

- Evaluate arguments for validity, objectivity and soundness;
- Argue a point after having gathered and synthesized relevant information, data and evidence;
- Critique text in terms of style and relate a text to the period in which it was written;
- Distinguish fallacies in arguments and be able to recognize the validity or lack of validity of various points of view.

REQUIRED CORE		UNITS
English 102	College Reading & Composition II	3
English 103	Composition & Critical Thinking	3

LIST A: Select two (2) courses: 6

English 203	World Literature I
English 205	English Literature I
English 206	English Literature II
English 208	American Literature II

LIST B: Select two (2) courses: 6

English 127	Creative Writing
-------------	------------------

or Any **LIST A** course not already used

LIST C: Select one (1) course: 3

Chicano 37	Chicano Literature
or Chicano 42	Contemporary Mexican Literature
Spanish 1	Elementary Spanish I
or Spanish 2	Elementary Spanish II
or Spanish 3	Intermediate Spanish I
or Spanish 4	Intermediate Spanish II
or Spanish 5	Advanced Spanish I
or Spanish 6	Advanced Spanish II
Theater 100	Introduction to Theater

or Any **LIST A** or **LIST B** course not already used

Total 18-20

NOTE: A minimum of 60 units and a cumulative GPA of 2.0 or higher must be completed to earn the Associate in Arts for Transfer. Always consult a counselor for information on graduation requirements, residency requirements and transfer information.

21 ENGLISH FUNDAMENTALS (NDA) 3 UNITS
Prerequisite: DevCom 1 or appropriate skill level demonstrated through the ENL assessment process | Lecture 3 hrs

NOTE: Class is graded pass/no-pass

This is a course in reading and writing designed to strengthen the student's basic communication skills, including grammar, spelling, punctuation, and sentence construction. Greatest emphasis is placed on the writing of competent paragraphs and short essays.

28 INTERMEDIATE READING (NDA) 3 UNITS & COMPOSITION

Prerequisite: English 21 with a grade of "C" or better or appropriate skill level demonstrated through the ENL assessment process, or by permit | Lecture 3 hrs

A course in reading and writing designed to strengthen the student's ability to use basic communication skills, including grammar, punctuation, and mechanics. Instruction will include the assignment of expository and argumentative essays, online grammar and writing exercises, and a research paper.

101 COLLEGE READING (UC:CSU) 3 UNITS & COMPOSITION I

Prerequisite: English 28 or ESL 8 or appropriate skill level demonstrated through the ENL assessment process | Lecture 3 hrs

Develops proficiency in college-level reading and writing through the application of the principles of rhetoric, argument, and critical thinking. Students will write expository essays based on college-level readings. Emphasis is placed on the research paper. This course requires the writing of a minimum of 6000 words in essays and a research paper.

Disciplines • Educational Programs • Course Descriptions

102 COLLEGE READING & COMPOSITION II (UC:CSU) 3 UNITS

Prerequisite: English 101 | Lecture 3 hrs

An introduction to critical analysis of poetry, novels, short stories, and drama. A variety of analytical strategies will be used to distinguish between deductive and inductive reasoning. Emphasis is placed on writing a research paper.

103 COMPOSITION & CRITICAL THINKING (UC:CSU) 3 UNITS

Prerequisite: English 101 | Lecture 3 hrs

Develops critical thinking and writing skills and emphasizes logical reasoning, analysis, and strategies of argumentation using expository prose as subject matter. Designed to improve critical thinking in written arguments by applying established modes of reasoning, analyzing rhetorical strategies, evaluating logical fallacies, and detecting bias.

127 CREATIVE WRITTING (UC:CSU) 3 UNITS

Prerequisite: English 101 | Lecture 3 hrs

Teaches students different ways to employ the elements of story in their original literary works and encourages them to find their own distinct voice as writers. Assignments consist of writing in various forms such as short story, poetry, play writing and creative nonfiction, critiquing the works of established writers and peers, and reading and discussing the process and conventions of the creative writing process.

203 WORLD LITERATURE I (UC:CSU) 3 UNITS

Prerequisite: English 101 | Lecture 3 hrs

An introduction to the key literary works of the Western world, the Middle East, Africa, and Asia, from antiquity to the seventeenth century. Students will analyze readings, poetic forms, and literary themes from different cultures in reasoned analysis.

205 ENGLISH LITERATURE I (UC:CSU) 3 UNITS

Prerequisite: English 101 | Lecture 3 hrs

An introduction to major works of English literature from the origins to the nineteenth century. Emphasis is placed on developing an understanding and appreciation of the poetry, fiction, and drama of these literary periods.

206 ENGLISH LITERATURE II (UC:CSU) 3 UNITS

Prerequisite: English 101 | Lecture 3 hrs

An introduction to major works of English literature from the nineteenth century to the present. Focus will be on developing an understanding and appreciation of the poetry, fiction, and drama of these literary periods.

208 AMERICAN LITERATURE II (UC:CSU) 3 UNITS

Prerequisite: English 101 | Lecture 3 hrs

Presents representative pieces of American literature from the early 19th century to the present. The selections are taken from a wide variety of literary forms, such as essays, short stories, poems, letters, speeches, and novels.

240 LITERATURE & THE MOTION PICTURE I (UC:CSU) 3 UNITS

Prerequisite: English 101 | Lecture 3 hrs

Examines the comparative arts of literature and the motion picture. Includes readings of literary works, both classic and modern, screenings of film versions based upon these literary sources, discussion, and writing of critical papers.

ENGLISH AS A SECOND LANGUAGE ESL / DEV COM / LEARNING SKILLS

FACULTY: Gary Prostack, Chair

Michael J. Climo, Vice Chair | Riye Park

1 COLLEGE ENGLISH AS A SECOND LANGUAGE I (NDA) 12 UNITS

Prerequisite: None | Lecture 12 hrs

NOTE: Class is graded pass/no-pass

A low-beginning integrated skills course for non-native learners of English. Emphasis is on the development of basic listening, speaking, pronunciation, reading, writing, and vocabulary abilities.

2 COLLEGE ENGLISH AS A SECOND LANGUAGE II (NDA) 12 UNITS

Prerequisite: ESL 1 or appropriate placement
Lecture 12 hrs

NOTE: Class is graded pass/no-pass

A high-beginning integrated skills course for non-native learners of English. Emphasis is on the development of basic listening, speaking, reading, writing, and vocabulary abilities.

3A COLLEGE ESL 3A: GRAMMAR/WRITING (NDA) 6 UNITS

Prerequisite: ESL 2 or appropriate placement
Lecture 6 hrs

NOTE: Class is graded pass/no-pass

This is a low-intermediate writing and grammar course for non-native writers of English. It emphasizes vocabulary, grammar, and writing through guided and free compositions of paragraphs on common subjects. Reading, speaking, and listening activities reinforce writing and grammar development.

NOTE: ESL courses at levels 3, 4, 5, and 6 are divided into three sections:

- A. Writing and Grammar
 - B. Reading and Vocabulary
 - C. Listening and Speaking
- Students are highly encouraged to enroll in all three sections (A, B, C).



ESL, English and Developmental Communication Course Sequence

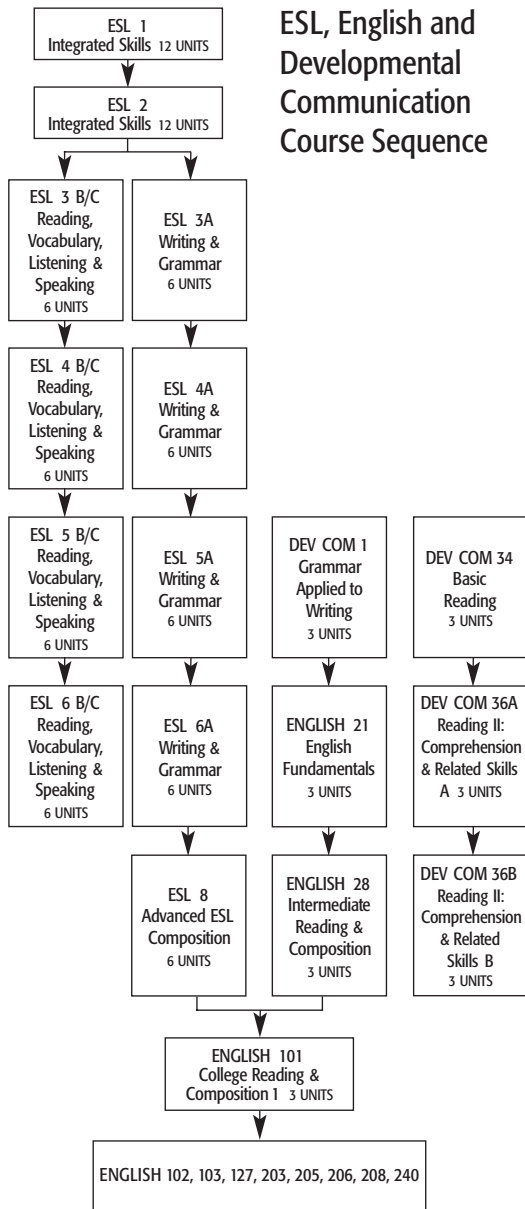

3B COLLEGE ESL 3B: READING/VOCABULARY (NDA) 3 UNITS

Prerequisite: ESL 2 or appropriate placement
Lecture 3 hrs

NOTE: Student must take 3B + 3C together
NOTE: Class is graded pass/no-pass

A low intermediate reading and vocabulary course that emphasizes the development of reading skills and the beginning of academic vocabulary.

3C COLLEGE ESL 3C: LISTENING/SPEAKING (NDA) 3 UNITS

Prerequisite: ESL 2 or appropriate placement
Lecture 3 hrs

NOTE: Student must take 3B + 3C together
NOTE: Class graded credit/no credit.

This is a low-intermediate listening and speaking course for non-native speakers of English. Emphasis is on the development of listening comprehension skills, the acquisition of conversational grammar, basic English pronunciation skills, and participation in interactive speaking activities in academic and social contexts.

4A COLLEGE ESL 4A: WRITING/GRAMMAR (NDA) 6 UNITS

Prerequisite: ESL 3A or appropriate placement
Lecture 6 hrs

NOTE: Class is graded pass/no-pass

This is a course in written composition, grammar, and critical reading skills tailored for the English-as-a-second language student. Students in this intermediate ESL course learn skills in writing to prepare them for college work. The emphasis is on writing based on critical reading and personal experience. Students will be introduced to summarizing skills. Grammar skills and mechanics are emphasized throughout each lesson.

4B COLLEGE ESL 4B: READING/VOCABULARY (NDA) 3 UNITS

Prerequisite: ESL 3B or appropriate placement
Lecture 3 hrs

NOTE: Student must take 4B + 4C together
NOTE: Class is graded pass/no-pass

A high intermediate reading and vocabulary course that emphasizes the development of reading skills and the beginning of academic vocabulary.

4C COLLEGE ESL 4C: LISTENING/SPEAKING (NDA) 3 UNITS

Prerequisite: ESL 3C or appropriate placement
Lecture 3 hrs

NOTE: Student must take 4B + 4C together
NOTE: Class is graded pass/no-pass

This is a high-intermediate listening and speaking class that focuses on listening to short lectures, developing conversational ability, and improving pronunciation.

5A COLLEGE ESL 5A: WRITING/GRAMMAR (NDA) 6 UNITS

Prerequisite: ESL 4A or appropriate placement
Lecture 6 hrs

NOTE: Class is graded pass/no-pass

This is a course in written composition, grammar, and critical reading skills tailored for the English-as-a-second language student. Students in this low-advanced ESL course learn skills in writing to prepare them for college work. The emphasis is on writing based on critical reading, interpretation/analysis, and personal experience. Students will develop paraphrasing and summarizing skills. Grammar skills and mechanics are emphasized throughout each lesson. Required: Eight to ten writing assignments, including at least four compositions of 300-400 words.

Disciplines • Educational Programs • Course Descriptions

5B COLLEGE ESL 5B: READING/VOCABULARY (NDA) 3 UNITS

Prerequisite: ESL 4B or appropriate placement
Lecture 3 hrs

NOTE: Student must take 5B + 5C together

NOTE: Class is graded pass/no-pass

This is a reading and vocabulary course that focuses on reading fictional and non-fictional materials. Students will study vocabulary lists and learn vocabulary development skills to become low-advanced ESL readers.

5C COLLEGE ESL 5C: LISTENING/SPEAKING (NDA) 3 UNITS

Prerequisite: ESL 4C or appropriate placement
Lecture 3 hrs

NOTE: Student must take 5B + 5C together

NOTE: Class is graded pass/no-pass

This is a low-advanced listening and speaking class that focuses on listening to academic lectures, developing conversational and presentation ability, and understanding enunciation techniques.

6A COLLEGE ESL 6A: WRITING/GRAMMAR (NDA) 6 UNITS

Prerequisite: ESL 5A or appropriate placement
Lecture 6 hrs

NOTE: Class is graded pass/no-pass

Students learn written composition, grammar, and critical reading skills to prepare for college work. The emphasis is on writing based primarily on critical reading and interpretation/analysis. Students will be introduced to appropriate citation and basis bibliographic citations. Advanced grammar and mechanics are emphasized. Required: 8 to 10 writing assignments, including at least 4 essays of 400-600 words.

6B COLLEGE ESL 6B: READING/VOCABULARY (NDA) 3 UNITS

Prerequisite: ESL 5B or appropriate placement
Lecture 3 hrs

NOTE: Student must take 6B + 6C together

NOTE: Class is graded pass/no-pass

This course focuses on advanced reading and vocabulary development for students whose first language is not English. Students will read high interest fictional and non-fictional books and materials at an advanced ESL level.

6C COLLEGE ESL 6C: LISTENING/SPEAKING (NDA) 3 UNITS

Prerequisite: ESL 5C or appropriate placement
Lecture 3 hrs

NOTE: Student must take 6B + 6C together

NOTE: Class is graded pass/no-pass

This is an advanced listening and speaking class for non-native speakers of English that focuses on listening to long academic lectures, developing critical conversational and presentation ability, and improving advanced English pronunciation.

8 ADVANCED ESL COMPOSITION (UC:CSU) 6 UNITS

Prerequisites: ESL 6A or English 21 or appropriate placement | Lecture 6 hrs

NOTE: Student receives a letter grade

A course in written composition and critical reading skills tailored for the English-as-a-second-language student. Emphasis is on advanced language development, grammar skills, critical reading, and the writing of expository and argumentative essays and research papers.

ENGLISH AS A SECOND LANGUAGE *NON-CREDIT*

FACULTY: Dennis Solares, Coordinator

7CE ENGLISH AS A SECOND LANGUAGE – I NON-CREDIT

Prerequisite: None | Lecture 12 hrs

This is an open-entry open-exit course that emphasizes listening/speaking skills and reading/writing skills at a beginning level. The focus of the course is comprehension and communication at the basic skills level in relation to familiar contexts, such as health, survival skills, employment, and community resources. Basic grammatical structures are introduced.

8CE ENGLISH AS A SECOND LANGUAGE – II NON-CREDIT

Prerequisite: None | Lecture 12 hrs

An open-entry open-exit course that emphasizes listening/speaking skills and reading/writing skills at a beginning level. The focus of the course is on comprehending and engaging in extended conversations related to familiar contexts, such as health, employment, and community resources. Students read simple adapted narrative and descriptive passages and use basic grammatical structures to write short, clearly organized paragraphs and messages.

9CE ENGLISH AS A SECOND LANGUAGE – III NON-CREDIT

Prerequisite: None | Lecture 12 hrs

Course emphasizes listening/speaking and reading/writing skills at an intermediate-low level.

Students participate in dialogues, open discussions, presentations, and journal writing about current events and cultural awareness. Students will develop skills to understand short reading passages and differentiate between fact and opinion with some accuracy as well as write clear and well-organized level appropriate short paragraphs. Completion of levels I and II or equivalent skills level is strongly recommended prior to registration.

15CE ENGLISH AS A SECOND LANGUAGE IV (NON-CREDIT)

Prerequisite: ESL 9CE | Lecture 12 hours

ESL IV is designed to provide a transition from non-credit ESL level 3, to college credit ESL or ENL courses. The focus of the course is on continued development of reading, writing, speaking, and comprehension skills; composition of paragraphs with level-appropriate grammar and sentence structure; and oral presentations that demonstrate basic research and critical thinking skills in use of multimedia sources. Furthermore, transition strategies for transfer onto college credit courses are studied.

23CE ENGLISH AS A SECOND LANGUAGE – SPEECH I NON-CREDIT

Prerequisite: None | Lecture 6 hrs

An open-entry open-exit course centered on basic oral communication skills at the intermediate low ESL level. Pronunciation, rhythm, stress, and intonation are practiced for better oral communication and development of patterns of English conversation. Students learn to give brief prepared oral presentations.

ESL CIVICS
NON-CREDIT

FACULTY: Dennis Solares, Coordinator

1CE CIVICS NON-CREDIT

Prerequisite: None | Lecture 3 hrs

This is an open-entry/open exit course. Intended for beginning high to intermediate low English Language Learners. Designed to introduce students to the United States naturalization process, and instruction in United States history, and government. Students will be able to identify the basic naturalization interview skills necessary to become a citizen and communicate in standard American English in academic, professional and life skills situations.

ENVIRONMENTAL SCIENCE
LIFE SCIENCES

FACULTY: J. Michael Reynolds, Chair

2 THE HUMAN ENVIRONMENT: (UC:CSU) 3 UNITS BIOLOGICAL PROCESSES

Prerequisite: English 28 or ESL 8 | Lecture 3 hrs

Introduces students to the biological aspects of our environmental systems. Study focuses on our large-scale systems including populations and ecosystems and small-scale issues such as nutrition and toxicity. Global population will be examined through the lens of population dynamics and carrying capacity.

FAMILY & CONSUMER STUDIES
CHILD & FAMILY STUDIES

FACULTY: Janice Silver, Chair

EDUCATIONAL PROGRAMS

This curriculum is designed to provide an opportunity for the student to complete lower-division courses that may lead to an occupational Certificate, an Associate in Arts Degree, and/or transfer to a four-year college or university. A student completing the Family & Consumer Studies major (formerly Home Economics) is eligible

for entry level jobs that may lead to a career as a consumer consultant, test kitchen home economist, (product and equipment demonstrators), nutrition (nutrition consultant, dietitian for institutions or individuals), interior design, consumer education (credit department employee, money management specialist, savings bank home economist, family financial economist, appliance specialist, credit counselor), marriage and family life, radio and television, journalism, advertising, gerontology (aide in home for senior citizens, community recreation programs and public housing projects, consultant in rehabilitation specialist, welfare home economist). Specialized programs are available in nutrition, consumer education, marriage and family, and gerontology as part of a two-year curriculum leading to an Associate in Arts Degree with a major in Family & Consumer Studies, or a Certificate in the various options.

NOTE: A minimum of 60 units and a cumulative GPA of 2.0 or higher must be completed to earn the Associate in Arts Degree. Always consult a counselor for information on graduation requirements, residency requirements and transfer information.

Program Learning Outcomes –

Upon completion, students will be able to:

- Demonstrate skills necessary to function in family roles and relationships which are transferable roles and responsibilities within the workforce and community;
- Students will demonstrate and analyze career opportunities, examine employability skills, and traits in families and communities;
- Demonstrate personal and family management skills that transfers to the workplace.



Disciplines • Educational Programs • Course Descriptions

ASSOCIATE IN ARTS - Family Studies

For General Education Requirements, see page 73
Students will explore family development and family interactions, as well as current issues facing families. This degree will prepare the student for a career working with families in areas such as parenting, advocacy, social services, and family support programs.

Program Learning Outcomes –

Upon completion, students will be able to:

- Analyze the needs, characteristics and multiple influences on families.
- Examine the reciprocal relationships between individuals, families and communities.
- Collect and evaluate current services available to support families in the home and community..

REQUIRED COURSES		UNITS
Ch Dev1	Child Growth & Development	3
Ch Dev 11	Child, Family & Community	3
Fam&CS 31	Marriage & Family Life	3
Fam&CS 70	Field Experience in Family & Consumer Studies	3
Select two courses		6
Ch Dev 55	Home Visitation Programs	
Fam&CS 6	Challenges of Aging	
Fam&CS 91	Life Management	
Soc 28	The Family: A Sociological Approach	
Soc 31	Sociology of Gender	
Psych 41	Life Span Psychology	
Total		18

ASSOCIATE IN ARTS - Foods & Nutrition

For General Education Requirements, see page 73

Program Learning Outcomes –

Upon completion, students will be able to:

- Demonstrate basic meal management and preparation techniques;
- Demonstrate basic principles of sanitation and safety relating to meal management;
- Demonstrate basic food preparation techniques to achieve quality standards and preserve nutritive value.

REQUIRED COURSES		UNITS
CAOT 82	Microcomputer Software Survey in the Office	3
ClnArt 50	Sanitation & Safety (<i>formerly FSMgmt 50</i>)	2
ClnArt 101	Culinary Fundamentals I (<i>formerly FSMgmt 101</i>)	4
ClnArt 105	Menu Planning (<i>formerly FSMgmt 103</i>)	2
ClnArt 150	Chef Training for Apprenticeship I (<i>formerly FSMgmt 108</i>)	2
ClnArt 155	Chef Training for Apprenticeship II (<i>formerly FSMgmt 108</i>)	2
Fam&CS 21	Nutrition	3
Fam&CS 22	Nutrition & the Consumer	3
Fam&CS 23	Nutritional Aspects of Weight Control	2
Fam&CS 26	Modified Diets	3
Fam&CS 91	Life Management	3
Total		29
RECOMMENDED COURSES		
ChDev 10	Health, Safety & Nutrition	3
Health 11	Principles of Healthful Living	3

ASSOCIATE IN ARTS - Gerontology

For General Education Requirements, see page 73
Students will explore social service and health care needs of the elderly as they apply to workforce opportunities. This degree will prepare the student for a career working with the aging or elderly in areas such as recreation, homecare, and healthcare aides within assisted living facilities.

Program Learning Outcomes –

Upon completion, students will be able to:

- Collect and evaluate current services available to the aging and elderly
- Examine the contemporary policy issues facing the field of Gerontology
- Demonstrate application of theory to practice in the field of aging and the delivery of direct services to the elderly and their families.

REQUIRED COURSES		UNITS
Fam&CS 6	Challenges of Aging	3
Fam&CS 21	Nutrition	3
Fam&CS 70	Field Experience in Family & Consumer Studies	3
Hlth Occ 63	Basic Medical Terminology, Pathophysiology, and Pharmacology	2
Hlth Occ 64	Cultural & Legal Topics for Healthcare Professionals	1
Hlth Occ 65	Fundamentals for the Healthcare Professional	2.5
Select two courses		6
Ch Dev 55	Home Visitation Programs	
Fam&CS 31	Marriage & Family Life	
Fam&CS 91	Life Management	
Psych 41	Life Span Psychology	
Soc 2	American Social Problems	

Total 20.5

CERTIFICATE OF ACHIEVEMENT

At the completion of the program, a Certificate will be awarded to the student. These Certificates are designed primarily for those students who have a limited time to pursue their career goals and wish to specialize in a particular aspect of Family & Consumer Studies that is job-related. They may seek upward mobility in their present job, or they may desire to prepare themselves for a new career. Most courses taken in the program apply toward a curriculum leading to an Associate Degree in Family & Consumer Studies.

Program Learning Outcomes –

Upon completion, students will be able to:

- Demonstrate the application of the decision making process to personal decisions such as parenthood that have lifelong impact;
- Determine the roles and responsibilities of parents and other care givers related to the emotional and social development of children;
- Demonstrate the consequences and responsibilities of personal decisions.

Gerontology Certificate of Achievement

Program Learning Outcomes –

Upon completion, students will be able to:

- Collect and evaluate current services available to the aging and elderly
- Examine the contemporary policy issues facing the field of Gerontology
- Demonstrate application of theory to practice in the field of aging and the delivery of direct services to the elderly and their families.

REQUIRED COURSES

		UNITS
Fam&CS 6	Challenges of Aging	3
Fam&CS 21	Nutrition	3
Fam&CS 70	Field Experience in Family & Consumer Studies	3
Hlth Occ 63	Basic Medical Terminology, Pathophysiology, and Pharmacology	2
Hlth Occ 64	Cultural & Legal Topics for Healthcare Professionals	1
Hlth Occ 65	Fundamentals for the Healthcare Professional	2.5
Select two courses		6
Ch Dev 55	Home Visitation Programs	
Fam&CS 31	Marriage & Family Life	
Fam&CS 91	Life Management	
Psych 41	Life Span Psychology	
Soc 2	American Social Problems	
Total		20.5

Certificates of Accomplishment

The student will be given a Certificate of Accomplishment following the completion of any of the following programs if the student has maintained a minimum of a C grade in all required courses. Certificates of Accomplishment are for students who have limited time and wish to limit their commitment but desire an increased level of specialization. Most courses taken in the programs apply toward curriculum leading to a Certificate of Achievement or the Associate Degree. Always consult a counselor for information on graduation requirements and transfer information.

Introduction to Hospitality Certificate of Accomplishment

Program Learning Outcomes –

Upon completion, students will be able to:

- Explain the types of businesses that make up the hospitality industry;
- Demonstrate the principal characteristics of service and contract it to deliver of a physical product;
- Demonstrate knowledge of diverse workforce and alterations in family structure that affect consumer behavior and the markets for hospitality services.

REQUIRED COURSES

		UNITS
CAOT 82	Microcomputer Software Survey in the Office	3
Cln Art 60	Culinary Arts Orientation & Techniques (Formerly FSMgmt100)	4
Cln Art 108	Restaurant Supervision & Training (Formerly Fam&CS109)	2
Fam&CS 91	Life Management	3
Fam&CS112	Managing Guest Relations	3
Total		15

RECOMMENDED COURSE

Cln Art 104	Dining Room & Beverage Management (Formerly FsMgmt 104)	4
-------------	---	---

6 CHALLENGES OF AGING (CSU) 3 UNITS

Prerequisite: None | Lecture 3 hrs

An examination of the developmental changes and specific needs of the older adult. Included is investigation of everyday situations with emphasis on consumerism, housing, health, nutrition, community resources and changing family roles.

Disciplines • Educational Programs • Course Descriptions

21 NUTRITION (UC:CSU) 3 UNITS

Prerequisite: None | Lecture 3 hrs

Advisory: English 21

Nutrition is the science that deals with the role of nutrients in the human body. These scientific concepts are related to individual needs during the changing life cycles. Interrelationships of nutrients are evaluated for promotion of optimum health.

23 NUTRITIONAL ASPECTS OF WEIGHT CONTROL (CSU) 2 UNITS

Prerequisite: Fam&CS 21 and FSMgmt 50 or ClnArt 50 | Lecture 2 hrs

Food composition and nutritional aspects of food preparation during weight control will be explored. Causes of obesity will be analyzed. Plans for weight control will be examined.

26 MODIFIED DIETS (CSU) 3 UNITS

Prerequisite: Fam&CS 21 and FSMgmt 50 or ClnArt 50 | Lecture 3 hrs

Modification of the normal diet to meet the needs of individuals according to age, disease, surgery and other health conditions. Current concepts of diet modification related to health are explored. Diets frequently used in health care institutions are included.

31 MARRIAGE & FAMILY LIFE (UC:CSU) 3 UNITS

Prerequisite: None | Lecture 3 hrs

Course includes the family as a social institution, its structure and functions, including historical changes in marriage, emerging patterns, and the influence of contemporary society and social forces that shape marriage and family such as race, class, gender and sexuality.

50 SANITATION & SAFETY (CSU) 3 UNITS

Prerequisite: None | Lecture 3 hrs

An introduction to basic principles of sanitation, safety, work simplification and use and care of institutional food service equipment. Emphasis is on the importance of proper employee training practices as related to food safety.

70 FIELD EXPERIENCE IN FAMILY & CONSUMER STUDIES (CSU) 3 UNITS

Prerequisite: Fam&CS 6 or 31

Lecture 2 hours, lab 2 hours

Field experience in a program offering services related to a certificate being earned in Family and Consumer Studies. The student will relate theory and coursework to practical application in a program, agency, facility or family service center.

91 LIFE MANAGEMENT (CSU) 3 UNITS

Prerequisite: None | Lecture 3 hrs

Provides students with the opportunity to develop their own career, academic and personal goals and to explore how these goals impact and are impacted by daily lifestyle. Based on theories, professional resources and practical experiences, students will develop strategies leading to professional, academic and personal success.

185 DIRECTED STUDY (CSU) 1 UNIT

Directed Study in Family and Consumer Studies on a contract basis under the direction of a supervising instructor.

285 DIRECTED STUDY (CSU) 2 UNITS

Directed Study in Family and Consumer Studies on a contract basis under the direction of a supervising instructor.

385 DIRECTED STUDY (CSU) 3 UNITS

Directed Study in Family and Consumer Studies on a contract basis under the direction of a supervising instructor.

FINANCE BUSINESS / LAW

FACULTY: Vilma Bernal, Chair | Steven Nerud

EDUCATIONAL PROGRAM

The Finance and Banking curriculum provides an in-depth understanding of the operations of money and capital markets, institutions and management. The Finance and Banking curriculum is designed to prepare students for employment in such fields as investing, banking, corporate finance, insurance, savings and loans, credit unions, mortgage banking and related fields. Breadth is obtained in the program by completing all recommended or suggested electives.

NOTE: A minimum of 60 units and a cumulative GPA of 2.0 or higher must be completed to earn the Associate in Arts Degree. Always consult a counselor for information on graduation requirements, residency requirements and transfer information.

ASSOCIATE IN ARTS - Finance

For General Education Requirements, see page 73

Program Learning Outcomes -

Upon completion, students will be able to:

- Apply ethical values, global awareness, and technological skills to identify financial problems and issues and make appropriate decisions;
- Apply critical thinking skills to formulate viable solutions to finance problems by using basic accounting, business, and financial concepts.

REQUIRED COURSES		UNITS
Acctg 1	Introductory Accounting	5-6
or Acct 21 + 22		
Acctg 2	Introductory Accounting	5
Acctg 25	Automated Accounting Methods & Procedures	3
Bus1	Introduction to Business	3
Bus 5 or Law 1	Business Law I	3
CAOT 31	Business English	3
CAOT 82	Microcomputer Software Survey in the Office	3
Econ 1	Principles of Economic	3
Econ 2	Principles of Economics	3
Finance 1	Principles of Finance	3
Finance 2	Investments	3
Finance 8	Personal Finance and Investments	3
Market 21	Principles of Marketing	3
Mgmt 2	Organization & Management Theory	3
Choose one (1) of the three (3) courses below:		
CAOT 1	Keyboarding	3-4
CAOT 32	Business Communications	
Math 227	Statistics	

Total 49-51

1 PRINCIPLES OF FINANCE (CSU) 3 UNITS

Prerequisite: None | Lecture 3 hrs

This course is designed to cover the markets in which funds are traded, the financial institutions that participate in and aid the flow of funds, and the principles of financial management that guide the participants in making sound decisions.

2 INVESTMENTS (CSU) 3 UNITS

Prerequisite: None | Lecture 3 hrs

A survey of the range of investment opportunities available and their characteristics. Included are stocks, options, commodities, bonds, government securities, real estate and savings. Includes investment objectives, and personal portfolio and administration.

8 PERSONAL FINANCE (CSU) 3 UNITS

& INVESTMENTS

Prerequisite: None | Lecture 3 hrs

Helps the individual manage, optimize and preserve personal income, expenditure and investments. Discussions will be focused on institutions that exist to serve the consumer. Attention will be given to family budgeting, consumer protection, buying on credit and borrowing money, home ownership and financing, different types of insurance, retirement planning and investments.

Food Service Management

See CULINARY and BAKING

FRENCH
FOREIGN LANGUAGES

FACULTY: Dr. Jolie Scheib, Chair

1 ELEMENTARY FRENCH I (UC:CSU) 5 UNITS

Prerequisite: None | Lecture 5 hrs

First course in understanding, speaking, reading, and writing French. Introduction to the cultures and civilization of the French-speaking world. Intended primarily for students with little or no knowledge of French.

2 ELEMENTARY FRENCH II (UC:CSU) 5 UNITS

Prerequisite: French 1 or equivalent

Lecture 5 hrs

Second course in understanding, speaking, reading and writing French. Continuation of the study of the cultures and civilization of the French-speaking world. Intended primarily for students with the equivalent knowledge of first-semester French.

GENERAL STUDIES
GENERAL STUDIES

This program provides an opportunity to earn an AA degree in a broad area of study and is intended for students who may not be planning to transfer to a 4-year university or who may need to explore possibilities before committing themselves to a major. This program may serve students who have been out of school and need to review and assess their academic skills and interests before deciding on a definite major program. Students are required to complete the general education requirements along with a minimum of 18 units in one area of concentration. Students interested in achieving a General Studies AA Degree must complete the following:

1. Completion of general education requirements
2. Complete a minimum of 18 units in one area of concentration;
3. Complete a minimum of 60 total units (electives may be necessary to total the 60 required units). Students planning to transfer to a 4-year university are cautioned that this curriculum may not provide for completion of the lower division requirements for transfer; however, careful educational planning with a counselor can help to ensure that if students did decide at a later date to transfer to a 4-year university, students would have a solid beginning in the transfer planning process. Please consult with a counselor for specific information regarding your possible intended major at the colleges/universities of choice.

Disciplines • Educational Programs • Course Descriptions

ASSOCIATE IN ARTS - General Studies Arts & Humanities

For General Education Requirements, see page 73
These courses emphasize the study of cultural, literary, humanistic activities and artistic expression of humanity. Students will learn to value aesthetic understanding and incorporate these concepts when constructing value judgments through evaluating and interpreting the ways in which people in different cultures have responded to themselves and the world around them in artistic and cultural creation throughout the ages. The Arts and Humanities Concentration allows students to take courses that will prepare them for possible career within the fields of Arts, Foreign Languages, Humanities, Film, Music, Philosophy, Religious Studies and more.

Program Learning Outcomes –

Upon completion, students will be able to:

- Analyze cultural, literary, humanistic activities and artistic expression of humanity;
- Synthesize aesthetic responsiveness and construct value judgments through evaluating and interpreting the ways in which people in different cultures have responded to themselves and the world around them in artistic and cultural creation throughout the ages;
- Prepare for a possible career within the fields of Arts, Foreign Languages, Humanities, Film, Music, Philosophy, and Religious Studies.

Anthro 104	IntrDgn 104
Art 101, 102, 103, 111, 201	Ling 1
Chicano 37, 52	MultiMd 100, 200, 620
Cinema 3	Music 101, 111, 141
English 102	Philos 1, 33
Human 1, 31	Theater 100, 200, 271
Any foreign language courses (max 5 units in same language) listed on IGETC or CSU GE advising form.	

Communication & Literature

For General Education Requirements, see page 73
These courses emphasize the content and form of communications to provide in-depth comprehension and understanding of the significance of communication. Students will be able to assess communication as the process of human symbolic interaction. Students will develop skills in the areas such as reasoning and advocacy, organization, analysis and critical evaluation, accuracy, reading and listening effectively to facilitate the decision-making process. The Communication and Literature Concentration allows students to take courses that will prepare them for possible careers within the fields of English (including Creative Writing and Journalism), Communications and more.
Coursework selected must be completed in at least two different disciplines.

Program Learning Outcomes –

Upon completion, students will be able to:

- Analyze the content, form and significance of types of communication;
- Assess communication as the process of human symbolic interaction;
- Demonstrate skills in the areas such as reasoning and advocacy, organization, analysis and critical evaluation, accuracy, reading and listening effectively to facilitate the decision-making process;
- Prepare them for a possible career within the fields of English Communications, including Creative Writing and Journalism.

Comm 101, 121, 151	Math 227
English 101, 102, 127, 208	Philos 5, 6
Journal 100	
Any Foreign Language at level II or higher (max 5 units in same language) listed on the IGETC or CSU-GE advising form.	

Natural Sciences

For General Education Requirements, see page 73
These courses emphasize the natural sciences which examine the physical universe, its life forms and its natural phenomena. The Natural Sciences Concentration allows students to take courses that may prepare them for possible careers within the fields of Science, including the Allied Health fields, Nursing Preparation, Health Science and related fields, Kinesiology and related fields, and more.

Program Learning Outcomes –

Upon completion, students will be able to:

- Examine the physical universe, its life forms and its natural phenomena;
- Prepare for a possible career within the fields of Science, including the Allied Health fields, Nursing Preparation, Health Science and related fields, Kinesiology and related fields.

Anatomy 1	Micro 20
Anthro 101	Oceano 1
Astron 1, 5	PhysSc 1, 14
Biology 3, 6, 7, 40	Physics 6, 7
Chem 51, 52, 65, 101, 102	Physiol 1
EnvSci 2	Psych 1
Fam&CS 21	Psych 2
Geog 1, 7, 14, 15	Soc 1
Geol 1	

Social & Behavioral Sciences

For General Education Requirements, see page 73
These courses emphasize the perspective, concepts, theories and methodologies of the disciplines typically found in the Social and Behavioral Sciences. Students will study about themselves and others as members of a larger society to stimulate critical thinking and evaluate how societies and social subgroups operate. The Social and Behavioral Sciences Concentration allows students

to take courses that may prepare them for possible careers within the fields of Chicano Studies, Psychology, Sociology, History, Political Science, and more. Coursework selected must be completed in at least two different disciplines.

Program Learning Outcomes –

Upon completion, students will be able to:

- Students will define and demonstrate knowledge of theories or research methodologies typically found in Social and Behavioral sciences.
- Students will demonstrate evidence of college level writing skills necessary for a possible career in the fields of Anthropology, Chicano Studies, Geography, History, Political Science, Psychology and Sociology.

AdmJus 1	Geog 1, 2, 7, 14
AfroAm 2, 4	History 1, 2, 11, 12, 13, 52, 86
Anthro 101, 102, 121	Law 1
Anthro 104	Ling 1
Biology 3	Math 227
Chicano 2, 7, 8	PolSci 1
ChDev 1	Psych 1, 2, 13
Econ 1, 2, 10	Soc 1, 2, 4, 11, 28
Fam&CS 31, 91	

GEOGRAPHY

PHYSICAL SCIENCES

FACULTY: Said Pazirandeh, Chair

1 PHYSICAL GEOGRAPHY (UC:CSU) 3 UNITS

Prerequisite: None | Lecture 3 hrs

Explores the earth's ever-changing physical system, including human activities where they interface with the environment. Emphasis is given to earth-sun relationships, atmosphere-hydrosphere interactions, lithospheric processes, integration of climate, soils and biomes and their spatial patterns. Students interpret the spatial patterns using maps produced from Geographic Information System (GIS), Global Positioning System (GPS), and satellite imagery.

2 CULTURAL ELEMENTS OF GEOGRAPHY (UC:CSU) 3 UNITS

Prerequisite: None | Lecture 3 hrs

Explores human cultural variables in the context of the globe, including the description, analysis, and explanation of population, migration, language, religion, ethnicity, political geography, and economic activities. Special emphasis is placed on the effects of globalization and the impact of human settlements on the natural environment. Tools of geographic inquiry may include maps, satellite imagery, and geographic information systems.

7 WORLD REGIONAL GEOGRAPHY (UC:CSU) 3 UNITS

Prerequisite: None | Lecture 3 hrs

Examines the world geographic realms, with a specific reference to physical landscapes, climates, demographics, cultural patterns, livelihoods, and integration in the global economy. Tools used for geographic inquiries may include analogue maps and digital images.

14 GEOGRAPHY OF CALIFORNIA (UC:CSU) 3 UNITS

Prerequisite: None | Lecture 3 hrs

This course of study elaborates on California's physical geography regions and natural resources in relation to patterns of population and economic activities, transportation routes and trade. Emphasis is placed on the state's history, demographics, ethnicity, land use and economy.

15 PHYSICAL GEOGRAPHY LABORATORY (UC:CSU) 2 UNITS

Prerequisite or Corequisite: Geog 1
Lecture 1 hr, Lab 2 hrs

Provides hands-on exercise in topics covered in the Physical Geography (Geog 1) course. This laboratory course deals with skills of collecting, analyzing, and displaying of geographic data, with a specific reference to Earth's energy balance, weather and climate, vegetation, tectonic processes, landforms, and natural hazards. Students use both analogue maps and digital media (GIS, GPS, satellite images, and Internet maps).



GEOLOGY

PHYSICAL SCIENCES

FACULTY: Said Pazirandeh, Chair

1 PHYSICAL GEOLOGY (UC:CSU) 3 UNITS

Prerequisite: None | Lecture 3 hrs

The course offers a study of the physical elements of the earth, with emphasis on the nature, distribution, and relationships of land forms, climate, soils, vegetation, and their integrated patterns of world distribution.

HEALTH

HEALTH / KINESIOLOGY / ATHLETICS

FACULTY: Leslie Milke, Chair
Cindy Cooper, Vice Chair

8 WOMEN'S PERSONAL HEALTH (UC:CSU) 3 UNITS

Prerequisite: None | Lecture 3 hrs

Presents health issues unique to women. Topics considered include physiological and psychological aspects of nutrition, exercise, hygiene, sexuality and reproduction, and diseases common to women. Open to men and women.

11 PRINCIPLES OF HEALTHFUL LIVING (UC:CSU) 3 UNITS

Prerequisite: None | Lecture 3 hrs

Offers health concepts to use today and tomorrow as guidelines for self-directed responsible living. Emphasis is placed on relating health concepts to the individual's well being in personal, community, vocational and leadership roles.

Disciplines • Educational Programs • Course Descriptions

HEALTH OCCUPATIONS LIFE SCIENCES

FACULTY: J. Michael Reynolds, Chair
Par Mohammadian, Vice-Chair

EDUCATIONAL PROGRAMS

CERTIFICATES OF ACCOMPLISHMENT

The student will be given a Certificate of Accomplishment following the completion of the following program if the student has maintained a minimum of a C grade in all required courses. Certificates of Accomplishment are for students who have limited time and wish to limit their commitment but desire an increased level of specialization.

Health Occupations offer satisfying and rewarding careers in fields that serve others and improve the health of individuals in the community. This certificate introduces students to fundamentals in health occupations. The courses introduce students to basic knowledge and skill sets required in health care as well as cultural and legal issues in health occupations. This certificate will serve as a stepping stone for other allied health programs.

Health Occupations Fundamentals Certificate of Accomplishment

Program Learning Outcomes –

Upon completion, students will be able to:

- Analyze and apply basic health care related skills, such as hygiene, safety, and basic concepts in patient care, such as ethics, medical terminology.

REQUIRED COURSES		UNITS
Hlth Occ 62	Skill Set for the Healthcare Professional	2
Hlth Occ 63	Basic Medical Terminology, Pathophysiology, and Pharmacology	2
Hlth Occ 64	Cultural & Legal Topics for Healthcare Professionals	1
Hlth Occ 65	Fundamentals for the Healthcare Professional	2.5
Ald Hth 21	Basic Life Support for the Healthcare Provider	0.5
		Total 8

62 SKILL SET FOR THE HEALTHCARE PROVIDER 2 UNITS

Prerequisite: None | Advisories: English 21 & Math 105 | Lecture 1 hr, Lab 3 hrs

Health Occupations 62 is an introduction of the concepts and skills that serve as a foundation for the healthcare professions. Topics include hygiene and safety, infection control, basic client monitoring and basic first aid, therapeutic communication and basic health documentation.

63 BASIC MEDICAL TERMINOLOGY, PATHOPHYSIOLOGY AND PHARMACOLOGY FOR THE HEALTHCARE PROFESSIONAL 2 UNITS

Prerequisite: None | Advisories: English 21 & Math 105 | Lecture 2 hrs

This basic medical language course will discuss common diseases and injuries and their pharmacological treatment using medical terminology in English and Spanish, when appropriate.

64 CULTURAL AND LEGAL TOPICS FOR THE HEALTHCARE PROFESSIONALS 1 UNIT

Prerequisite: None | Advisories: English 21 & Math 105 | Lecture 2 hrs

Health Occupations 64 provides an overview of the concepts of health and illness, cultural diversity and legal issues that affect the healthcare professional.

65 FUNDAMENTALS FOR THE HEALTHCARE PROFESSIONAL 2.5 UNITS

Prerequisite: None | Advisories: English 21 & Math 105 | Lecture 2.5 hrs

Health Occupations 65 explores career options in the health care industry, healthy behavior for health care workers, work ethics, professional resumes and interviewing skills and personality traits of a healthcare professional. There will be an externship during which area employers will introduce students to direct and indirect patient care opportunities.

HEALTH SCIENCE LIFE SCIENCES

This is an Associate in Science Program and not a discipline.

FACULTY: J. Michael Reynolds, Chair |
Dr. Stephen Brown | Dr. Angela Echeverri
Dr. Diane Livio | Dr. Par Mohammadian
Said Pazirandeh

EDUCATIONAL PROGRAM

This curriculum provides an orientation to the health sciences while including the general background required for the allied health fields and family environmental sciences.



ASSOCIATE IN SCIENCE - Health Science

For General Education Requirements, see page 73

Program Learning Outcomes –

Upon completion, students will be able to:

- Explain two or more disease processes and their biological foundations;
- Demonstrate proper application of basic laboratory methods such as using a microscope, taking a blood pressure and plating bacteria using aseptic technique;
- Read and analyze current literature from simple biomedical journals.

REQUIRED COURSES

		UNITS
Biology 3	Introduction to Biology	4
or Biology 5	Introduction to Human Biology	
Anatomy 1	Introduction to Human Anatomy	4
Physiol 1	Introduction to Human Physiology	4
Chem 51	Fundamentals of Chemistry I	4-5
or Chem 65	Introductory General Chemistry	
Psych1	General Psychology I	3
or Soc1	Introduction to Sociology	
Math 227	Statistics (or higher)	4

Select one (1) required course: 4-5

Select one (1) elective course: 3-4

Total 30-33

REQUIRED COURSES (choose one):

Chem 52	Fundamentals of College Chemistry II	4
Micro 20	General Microbiology	4
Physics 6	General Physics I	4

ELECTIVE COURSES (choose one):

Psych 1	General Psychology I	3
Soc 1	Introduction to Sociology	3
Fam&CS 21	Nutrition	3
Physics 7	General Physics II	4

NOTE: A minimum of 60 units and a cumulative GPA of 2.0 or higher must be completed to earn the Associate in Science Degree. Always consult a counselor for information on graduation requirements, residency requirements and transfer information.

HISTORY

SOCIAL SCIENCES

FACULTY: Mark Pursley, Chair
D'Art Phares, Vice Chair

AMERICAN HISTORY INSTITUTIONS TRANSFER REQUIREMENT

If you took a U.S. history course outside of California, make certain you meet the California State and local government transfer requirements to the California State Universities as listed below. Please consult with a counselor or a history instructor.

U.S.-1 History – History 11, 12, AfroAm 4, Chicano 8, Econ 10

U.S.-2 Constitution – PolSci 1

U.S.-3 State and local government – PolSci 1

1 INTRODUCTION TO WESTERN CIVILIZATION I (UC:CSU) 3 UNITS

Prerequisite: None | Lecture 3 hrs

A survey course emphasizing the main political, social, and economic currents that shaped the development of Western Civilization from Paleolithic times through the 17th century.

2 INTRODUCTION TO WESTERN CIVILIZATION II (UC:CSU) 3 UNITS

Prerequisite: None | Lecture 3 hrs

A survey course emphasizing the main political, social, and economic currents that shaped the development of Western Civilization from the 17th century to today.

11 POLITICAL & SOCIAL HISTORY OF THE UNITED STATES I (UC:CSU) 3 UNITS

Prerequisite: None | Lecture 3 hrs

A general survey of the political and social developments that shaped the history of the United States from pre-Columbian times to Reconstruction.

12 POLITICAL & SOCIAL HISTORY OF THE UNITED STATES II (UC:CSU) 3 UNITS

Prerequisite: None | Lecture 3 hrs

Covers the second half of the standard survey of United States history, providing an analytical study of the history of the United States from the Reconstruction era to the present, focusing not only on political and social developments in the history of the United States but also on economic and cultural developments, and analyzing changes in both the United States' domestic policies and its ongoing and changing role in international affairs.

86 INTRODUCTION TO WORLD CIVILIZATION I (UC:CSU) 3 UNITS

Prerequisite: None | Lecture 3 hrs

A historical survey of the major political, economic, intellectual and cultural movements and events of Early World Civilizations from Early World History from the Paleolithic Era, through the 16th Century.

185 DIRECTED STUDY (CSU) 1 UNIT

Provides opportunity for in-depth study of a chosen area of History on a contract basis, under the direction of a supervising instructor.

285 DIRECTED STUDY (CSU) 2 UNITS

Provides opportunity for in-depth study of a chosen area of History on a contract basis, under the direction of a supervising instructor.

385 DIRECTED STUDY (CSU) 3 UNITS

Provides opportunity for in-depth study of a chosen area of History on a contract basis, under the direction of a supervising instructor.

Disciplines • Educational Programs • Course Descriptions

HUMANITIES ARTS, MEDIA & PERFORMANCE

FACULTY: Deborah Paulsen, Chair

EDUCATIONAL PROGRAM

The student in Humanities will have the opportunity to investigate the cultural, philosophical, sociological and historical trends which affect modern man. Studies of several cultures will be possible.

NOTE: Students are encouraged to take a foreign language as part of their college program.

NOTE: A minimum of 60 units and a cumulative GPA of 2.0 or higher must be completed to earn the Associate in Arts Degree. Always consult a counselor for information on graduation requirements, residency requirements and transfer information.

ASSOCIATE IN ARTS - Humanities

For General Education Requirements, see page 73

Program Learning Outcomes –

Upon completion, students will be able to:

- Communicate insights into the arts clearly, effectively, and with nuance in both oral and written form;
- Critically examine great works of the human imagination with significant reference to structure, metaphor, symbolism and subtext;
- Analyze how historical, political and social contexts influence various types of artistic expression;
- Articulate significant social, literary, and political perspectives found in humanities in such areas as class, ethnicity, gender, sex, and cultural orientation.

REQUIRED COURSES

Art 109	The Arts of Africa, Oceania & Ancient America	3
Human 30	The Beginning of Civilization	3
Music 111	Music Appreciation I	3
Select two (2) courses:		
Human 1	Cultural Patterns of Western Civilization	6
Human 2	Studies in Selected Cultures	
Human 3	The Arts of Contemporary Society	
Human 31	People in Contemporary Society	
Select one (1) course:		
Art 101	Survey of Art History I	3
Art 102	Survey of Art History II	
Philos 1	Introduction in Philosophy	
Philos 33	Comparative Survey of World Religions	

UNITS

3
3
3
6
3
Total 18

1 CULTURAL PATTERNS OF WESTERN CIVILIZATION (UC:CSU) 3 UNITS

Prerequisite: English 28 or ESL 8 | Lecture 3 hrs
An introduction to the general concepts of the Humanities. Mythology, music, history, philosophy, painting, drama, sculpture, architecture, and religion are studied and compared in relation to their background, medium, organization and style.

2 STUDIES IN SELECTED CULTURES (UC:CSU) 3 UNITS

Prerequisite: English 28 or ESL 8 | Lecture 3 hrs
The art, music, and literature of the cultures of the East, Middle East, Africa, and Ancient Americas are studied as they interrelate to reveal non-western views of philosophy, science, religion and the self.

3 THE ARTS OF CONTEMPORARY SOCIETY (UC:CSU) 3 UNITS

Prerequisite: English 28 or ESL 8 | Lecture 3 hrs
A study of the literature, philosophy, music, art and architecture of the late nineteenth and twentieth centuries in terms of the ideas and basic needs which stimulated the artists, and the contribution of their work toward the development of contemporary society.

30 THE BEGINNINGS OF CIVILIZATION (UC:CSU) 3 UNITS

Prerequisite: English 28 or ESL 8 | Lecture 3 hrs
A survey of cultural heritages from prehistoric times to the early civilizations of India, China, the Middle East, and Egypt; includes Classical Greek and Roman periods. Emphasis is placed on the arts, literature, religion, and cultural traditions of these civilizations.

31 PEOPLE IN CONTEMPORARY SOCIETY (UC:CSU) 3 UNITS

Prerequisite: English 28 or ESL 8 | Lecture 3 hrs
Cultural history of the arts, philosophies, science and politics of Western civilization from the Industrial Revolution to present. Evolutionary development, interrelationships and influences on modern culture are emphasized.

Interdisciplinary Studies

See General Studies.

INTERIOR DESIGN

ARTS, MEDIA & PERFORMANCE

FACULTY: Deborah Paulsen, Chair

EDUCATIONAL PROGRAM

The Interior Design Associate in Arts Degree prepares students for employment and transfer. Students study the elements and principles of design as applied to human and cultural needs for residential and commercial spaces, while utilizing technology and communications skills. The focus is on meeting today's standards including environmental and sustainability considerations and American Disabilities Act requirements.

NOTE: A minimum of 60 units and a cumulative G.P.A. of 2.0 or higher must be completed to earn the Associate in Arts Degree. Always consult a counselor for information on graduation requirements, residency requirements and transfer information.

ASSOCIATE IN ARTS - Interior Design

For General Education Requirements, see page 73

Program Learning Outcomes –

- Prepare students for entry level jobs in the field of Interior Design field and transfer to a university.
- Analyze and apply the elements and principles of design as applied to human and cultural needs for residential and commercial spaces, while utilizing technology and communications skills.
- Analyze and apply today's standards including environmental and sustainability considerations and American Disabilities Act requirements.

REQUIRED COURSES

		UNITS
Art 201	Drawing I	3
Art 209	Perspective Drawing I	3
Art 502	Beginning Three Dimensional Design	3
IntrDgn 102	Intro to Interior Design	3
IntrDgn 104	Historical & Contemporary Interior Design	3
IntrDgn 105	Textiles	3
IntrDgn 106	Drafting for Interior Designers	3
IntrDgn 108A	Residential Space Planning	3
IntrDgn 114	Interior Design Materials, Standards & Specifications	3
IntrDgn 116	Computer Aided Design & Drafting for Interior Design	3
	Total	30

CERTIFICATE OF ACHIEVEMENT

At the completion of the program, a certificate will be awarded to the student. This certificate is designed primarily for those students who have a limited time to pursue their career goals and wish to specialize in a particular aspect of interior design. They may seek upward mobility in their present job, or they may desire to prepare themselves for a new career. Most courses taken in the program apply toward a curriculum leading to an Associate Degree in Interior Design.

Interior Design Certificate

Program Learning Outcomes –

Upon completion, students will be able to:

- Demonstrate the understanding of design fundamentals, theory, process, communication and research;
- Demonstrate strategies about how to identify, comprehend, evaluate, and apply knowledge from reliable lighting sources pertaining to the lighting of the interior environment through the application of natural and artificial lighting sources;
- Demonstrate competency in the following areas: program and concept development, plan development and analysis, applications of design elements and principles to the design of interior spaces.

REQUIRED COURSES

		UNITS
IntrDgn 101	Professional Career Opportunities	2
IntrDgn 102	Introduction to Interior Design	3
IntrDgn 104	Historical & Contemporary Interior Design	3
IntrDgn 105	Textiles	3
IntrDgn 106	Drafting for Interior Designers	3
IntrDgn 108A	Residential Space Planning	3
IntrDgn 108B	Space Planning B (Commercial)	2
IntrDgn 109A&B	Kitchen & Bath Design	4
IntrDgn 110	Lighting	3
IntrDgn 111	Interior Design Portfolio	3
IntrDgn 112	Interiors Management	4
IntrDgn 113	Internship	2
	Total	35

SUGGESTED ELECTIVES

IntrDgn 103	Interior Design Project Laboratory	1
IntrDgn 107	Color for Interiors	3
IntrDgn 114	Interior Design Materials, Standards & Specifications	3
IntrDgn 115	Window Treatments	1

**Required for degree*

Disciplines • Educational Programs • Course Descriptions

CERTIFICATE OF ACCOMPLISHMENT ONLY

The student will be given a Certificate of Accomplishment following the completion of the following program.

Certificates of Accomplishment are for students who have limited time, and wish to limit their commitment, but desire an increased level of specialization. Most courses taken in the program apply toward curriculum leading to a Certificate of Achievement or the Associate Degree.

Program Learning Outcomes –

Upon completion, students will be able to:

- Demonstrate various designs of interiors;
- Demonstrate knowledge of lighting sources and their relative energy impacts and appropriateness to meet human needs via a lighting analysis assignment;
- Demonstrate application of technical information learned in previous courses, apply codes and regulations as appropriate to projects.

Intro to Interior Design Certificate of Accomplishment

Program Learning Outcomes –

Upon completion, students will be able to:

- Demonstrate awareness of the material cultures and life styles associated with past civilizations and their relevancy to contemporary design
- Demonstrate an understanding of the craftsmanship materials and technology as they relate to furniture and interior design
- Identify furniture styles and understand why a style developed and its relationship to social, economic and political conditions

REQUIRED COURSES		UNITS
IntrDgn 101	Professional Career Opportunities	2
IntrDgn 102	Introduction to Interior Design	3
IntrDgn 104	Historical & Contemporary Interior Design	3
		Total 8

Intro to Space Planning Certificate of Accomplishment

Program Learning Outcomes –

Upon completion, students will be able to:

- Demonstrate a variety of drawing media to reflect design development and solutions;
- Demonstrate design drawing, information gathering research and analysis, client and user needs;
- Demonstrate knowledge of construction, basics of kitchen and bath design, materials and estimations, lighting design and theme applications.

REQUIRED COURSES		UNITS
IntrDgn 106	Drafting for Interior Designers	3
IntrDgn 108A	Space Planning A (Residential)	3
IntrDgn 108B	Space Planning B (Commercial)	2
IntrDgn 109A	Kitchen Design	2
IntrDgn 109B	Bath Design	2
		Total 12

Technology & Interior Design Certificate of Accomplishment

Program Learning Outcomes –

Upon completion, students will be able to:

- Demonstrate some of the many different traditional, and contemporary styles of window treatment that designers use;
- Identify different design trends and construction techniques in fabrics, trimmings, and accessories;
- Demonstrate design light and detail, schematic design, reflected ceiling plans, and lighting calculations.

REQUIRED COURSES		UNITS
IntrDgn 110	Lighting	3
IntrDgn 114	Interior Design Materials, Standards & Specifications	3
IntrDgn 115	Window Treatments	1
GenEng 211	CADD for Engineers I	3
		Total 10

101 PROFESSIONAL CAREER OPPORTUNITIES (CSU) 2 UNITS

Prerequisite: None | Lecture 2 hrs

Presents an overview of career opportunities in the area of interior design. Career development planning is covered in addition to job interview techniques and resume writing. Course includes speakers from the profession and field trips.

102 INTRODUCTION TO INTERIOR DESIGN (CSU) 3 UNITS

Prerequisite: None | Lecture 3 hrs

Introduction to the field of interior design including the elements and principles of design as applied to color, textiles, wall coverings, window treatments, space planning, furniture and lighting selection. Introduces basic drafting techniques. Products, services and career options are overviewed.

103 INTERIOR DESIGN PROJECT LABORATORY (CSU) 1 UNIT

Prerequisite: None | Lab 3 hrs

Students will use this lab time to work on current interior design class projects in which they are enrolled with instructor supervision.

104 HISTORICAL & CONTEMPORARY INTERIOR DESIGN (CSU) 3 UNITS

Prerequisite: None | Lecture 3 hrs

Covers the historical developments in society and decorative arts that led to the development of interior design styles from Greek and Roman times to the present. Examines furniture design elements and construction, and architectural development.

105 TEXTILES (CSU) 3 UNITS
Prerequisite: None | Lecture 3 hrs
Analysis of man-made and natural fibers, construction, weaves, dyes and finishes, relating to the selection, use and care of fabrics for residential and commercial interior design. Testing, evaluation and identification are covered.

106 DRAFTING FOR INTERIOR DESIGNERS (CSU) 3 UNITS
Prerequisite: Art 201 | Lecture 2 hours, lab 2 hours
Introduces the fundamentals of drafting and visual communications for interior design, landscape architecture, and environmental design. Skills are taught in manual drafting and graphic communication of architecture and the built environment using two and three-dimensional drawing systems. The fundamentals of model building, sketching, digital drawing methods and spatial comprehension.

107 COLOR FOR INTERIORS (CSU) 3 UNITS
Prerequisite: None | Lecture 3 hrs
This course covers the developments and use of color as it relates to interior design. The psychology of color, textures and light effects, the historic value of color, color trends past and present, and color in residential and commercial interior design.

108 SPACE PLANNING A + B (CSU) 4 UNITS
Prerequisite: None | Lecture 2 hrs, Lab 4 hrs
Space planning for interior design with an emphasis on complete environmental planning including client requirements, ADA compliance, architectural considerations, interior and exterior relationships to residential and commercial design. This course includes presentation methods and field trips.

108A RESIDENTIAL SPACE PLANNING (CSU) 3 UNITS
Prerequisite: None | Lecture 2 hrs, Lab 2 hrs
This course covers space planning for interior design with an emphasis on complete environmental planning including humane and green environments, client requirements, ADA compliance, architectural

considerations, interior and exterior relationships in residential design. Covers basic drafting and 3D modeling techniques in developing design proposals.

109 KITCHEN & BATH DESIGN A + B (CSU) 4 UNITS
Advisory: IntrDgn 102 or IntrDgn115
Lecture 2 hrs, Lab 4 hrs
Kitchen design covers the cooking process, in relation to counters, cabinets, sinks, lighting, acoustics, flooring, safety, appliances and ergonomics. Bath design includes social, psychological and physical aspect of body care for residential, contract, public facilities and compliance with Americans with Disabilities Act.

110 LIGHTING (CSU) 3 UNITS
Prerequisite: None | Lecture 3 hrs
This course includes lighting basics, sources of light, lighting hardware, lighting applications and lighting as an art. Lighting specifications are covered. Applications including residential and commercial lighting are covered. Field trips required.

111 INTERIOR DESIGN PORTFOLIO (CSU) 3 UNITS
Advisory: IntrDgn102, or 106, or 108A, or 108B
Lecture 2 hrs, Lab 3 hrs
This course presents the professional tools needed to develop a professional portfolio of your interior design work as it progresses. Projects will be created and fine-tuned to include in a portfolio to secure a job in the profession.

112 INTERIORS MANAGEMENT (CSU) 4 UNITS
Prerequisite: None | Lecture 2 hrs, Lab 4 hrs
This course covers business procedures, contracts and business forms, time allocation and financial planning, bookkeeping and accounting procedures, complaints and adjustments, designer-client relations, compensations and fees, public relations and publicity.

113 INTERNSHIP (CSU) 2 UNITS
Prerequisite: None | Lecture 1 hr, Lab 3 hrs
This class provides supervised fieldwork experience with professionals. This class offers numerous opportunities and hands on training in the field in a non paid position. 108 hours of fieldwork required. Beginning to advanced positions available.

114 INTERIOR DESIGN MATERIALS, STANDARDS AND SPECIFICATIONS (CSU) 3 UNITS
Prerequisite: None | Lecture 2 hrs, Lab 2hrs
This course covers specifications of paints, finishes, flooring materials, both hard and soft, walls, ceilings, moldings, doors, and windows for residential and commercial applications. Students learn about interior products for durability, health, environmental, sustainability, and American Disability Act considerations.

115 WINDOW TREATMENTS (CSU) 1 UNIT
Prerequisite: None | Lecture 1 hr
This course covers window history, hard and soft window treatments and installations, specialty installations, residential and commercial specifications, sources for design concepts, calculating fabric requirements, measuring techniques used by installers, workrooms, and interior designers and job costing.

116 COMPUTER AIDED DESIGN AND DRAFTING FOR INTERIOR DESIGN (CSU) 3 UNITS
Prerequisite: Art 201 | Lecture 2 hrs, Lab 2 hrs
Lecture and laboratory introduces computer aided design and drafting for Interior Design. Students utilize computer and drafting techniques to apply the elements and principles of design and prepare architectural drawings on the computer.

Disciplines • Educational Programs • Course Descriptions

ITALIAN

FOREIGN LANGUAGES

FACULTY: Dr. Jolie Scheib, Chair

1 ELEMENTARY ITALIAN I (UC:CSU) 5 UNITS

Prerequisite: None | Lecture 5 hrs

First course in understanding, speaking, reading and writing Italian. Introduction to Italian culture and civilization. Intended primarily for students with little or no knowledge of Italian.

2 ELEMENTARY ITALIAN II (UC:CSU) 5 UNITS

Prerequisite: Italian 1 or equivalent | Lecture 5 hrs

Second course in understanding, speaking, reading and writing Italian. Continuation of the study of the culture and civilization of Italy. Intended primarily for students with the equivalent knowledge of first-semester Italian.

JOURNALISM

ENGLISH / COMMUNICATION STUDIES

FACULTY: Louise Barbato, Chair

100 SOCIAL VALUES IN MASS COMMUNICATION (UC:CSU) 5 UNITS

Prerequisite: English 101 | Lecture 3 hrs

A general interest survey and evaluation of the mass media in economic, historical, political, psychological and social terms. Focus is to help the media consumer better understand today's mass communications; newspapers, radio, television, motion pictures, magazines, the internet, advertising and public relations. Course content discusses relationships, ethics, rights and responsibilities of media in today's society.

KINESIOLOGY

HEALTH / KINESIOLOGY / ATHLETICS

FACULTY: Leslie Milke, Chair

Cindy Cooper, Vice Chair | Joe Cascione | Steve Ruys

For Dance Studies and Dance Techniques see page 118.

35 ADAPTED ACTIVITIES (UC:CSU) 1 UNIT

Prerequisite: None | Lab 2 hrs

Adaptive activities for students with disabilities. Beginning, intermediate and advanced levels offered. All levels may not be taught each semester. Includes modified postural and static contraction exercises; adaptive games; modified aerobic and rhythmic activities; and prescribed individual exercises.

49 ADAPTED CARDIO-VASCULAR FITNESS (UC:CSU) 1 UNIT

Prerequisite: None | Lab 3 hrs

This course is designed to meet the needs of students with disabilities who can benefit from individualized cardiovascular endurance through the use of bicycle ergometers, treadmills, etc.

201 SWIMMING SKILLS (UC:CSU) 1 UNIT

Prerequisite: None | Lecture .5 hr, Lab 1.5 hrs

This course is designed to include all levels of swimmers. Fundamental swimming skills will be developed and expanded upon. Water orientation, safety, poolside etiquette and components of fitness are included.

266 BADMINTON SKILLS (UC:CSU) 1 UNIT

Prerequisite: None | Lecture .5 hr, Lab 1.5 hrs

This course is designed to teach all skill levels. Basic strokes, footwork, and serves are introduced and expanded upon. Includes instruction on single and doubles strategy, rules, etiquette, and safety. Recreational and competitive play will be part of the class experience.

267 BOWLING SKILLS (UC:CSU) 1 UNIT

Prerequisite: None | Lab 2 hrs

This course provides instruction on the basic skills and rules of bowling. It addresses bowling etiquette, playing procedures and lifetime fitness components. Additional lab fee which includes shoes, ball, and game play.

268 GOLF SKILLS I (UC:CSU) 1 UNIT

Prerequisite: None | Lecture .5 hr, Lab 1.5 hrs

Introduces introductory principles/theories/skills of golf. The course introduces the basic and fundamental skills for the grip, stance, swing and posture required for golf. Students will be required to pay a fee at the driving range. This course is designed for the beginning level player

271 TENNIS SKILLS (UC:CSU) 1 UNIT

Prerequisite: None | Lecture .5 hr, Lab 1.5 hrs

Course intended for all skill levels. It covers fundamental tennis skills and a basic understanding of the game, rules, scoring, and strategies are included. Singles and doubles play will allow students to participate in various kinds of game play.

286 BASEBALL SKILLS (UC:CSU) 1 UNIT

Prerequisite: None | Lab 3 hrs

Course will focus on developing fundamental skills, strategies, knowledge of the rules and history of baseball. An opportunity for teamwork experience and game play will be provided. Open to all ability levels.

289 SOCCER SKILLS (UC:CSU) 1 UNIT

Prerequisite: None | Lab 3 hrs

Course will focus on developing fundamental skills, strategies, knowledge of the game and its rules while providing an opportunity for teamwork experience and game play. Open to all ability levels.

291 VOLLEYBALL SKILLS (UC:CSU) 1 UNIT

Prerequisite: None | Lecture .5 hr, Lab 1.5 hrs
The basic fundamentals of volleyball as well as some intermediate and advanced strategies and techniques for those who are past the novice stage are addressed. The components of fitness are addressed as well as how volleyball plays a role as a lifetime activity.

303 AQUA AEROBICS (UC:CSU) 1 UNIT

Prerequisite: None | Lecture .5 hr, Lab 2.5 hrs
A water aerobic exercise and conditioning class that emphasizes cardiovascular endurance and promotes fitness using water resistance. Students need not be a swimmer to participate in this class.

316 KARATE (UC:CSU) 1 UNIT

Prerequisite: None | Lecture .5 hr, Lab 2.5 hrs
Introduces students to the fundamental aspects of karate including basic kicking, punching, blocking, and grappling techniques. Through active participation, students will improve in the basic five components of fitness: cardio respiratory endurance, muscular strength, muscular endurance, flexibility, and body composition.

316-1 KARATE I (UC:CSU) 1 UNIT

Prerequisite: None | Lecture .5 hr, Lab 2.5 hrs
Introduces students to the fundamental aspects of karate including basic kicking, punching, blocking, and grappling techniques. Through active participation, students will improve in the basic five components of fitness: cardio respiratory endurance, muscular strength, muscular endurance, flexibility, and body composition.

316-2 KARATE II (CSU) 1 UNIT

Prerequisite: Kin 316-1
Lecture .5 hr, Lab 2.5 hrs
Students continue their education in the fundamental aspects of karate including basic kicking, punching, blocking, and grappling techniques. The science behind martial arts such as physiology and physics of how and why specific techniques apply in certain situations is emphasized. Through active practice, students improve in the basic five components of fitness: cardiovascular endurance, muscular strength, muscular endurance, flexibility, and body composition.

329 BODY CONDITIONING (UC:CSU) 1 UNIT

Prerequisite: None | Lab 3 hrs
The class will include various aerobic activities to enhance cardiovascular conditioning. Weight resistance exercises and stretching exercises will be included to develop muscle strength, endurance, and flexibility. Training principles and concepts along with nutritional information will be introduced.

330 CARDIO KICKBOXING (UC:CSU) 1 UNIT

Prerequisite: None | Lecture .5 hr, Lab 2.5 hrs
A non-contact aerobic activity course designed to use basic kicking and punching techniques to improve overall fitness including: cardio respiratory endurance, muscular strength and endurance, flexibility, and body composition. Weights, steps, and calisthenic exercises may also be utilized.

332 STEPS AEROBICS (UC:CSU) 1 UNIT

Prerequisite: None | Lecture .5 hr, Lab 2.5 hrs
This course is designed to improve cardiovascular fitness and strengthen select muscle groups by performing stepping skills in rhythm with music. Stepping is primarily a low impact aerobic exercise. Activity includes muscle conditioning and flexibility exercises.

347 PILATES MAT (UC:CSU) 1 UNIT

Prerequisite: None | Lecture .5 hr, Lab 2.5 hrs
Introductory techniques based on the Pilates concepts are used; concentration, control, center, fluidity, precision and breath. It is designed to improve flexibility while developing muscular strength and muscular endurance in the core muscles: abdominal area, lower back, hips, and buttocks.

350-1 WEIGHT TRAINING I (CSU) 1 UNIT

Prerequisite: None | Lecture .5 hr, Lab 2.5 hrs
Weight Training enhances the lifting skills and knowledge, including enhanced spotting techniques, enhanced lifting techniques and an introduction to more advanced exercises used in a weight training program. An increased emphasis will be placed in the knowledge, understanding, value and practical application of building muscle strength and endurance. The course will include an increased understanding of the human muscular system. The objective is to further enhance the student's ability to prepare their own physical fitness program at any time in their life and to assist others based upon sound physiological and bio-mechanical principles.

350-2 WEIGHT TRAINING II (CSU) 1 UNIT

Prerequisite: Kin 350-1 | Lecture .5 hours, Lab 2.5 hrs
Weight Training II provides a higher level of weightlifting skills and knowledge, including enhanced spotting techniques, enhanced lifting techniques and an introduction to more advanced exercises used in a weight training program. An increased emphasis will be placed in the knowledge, understanding, value and practical application of building muscle strength and endurance. The course will include an increased understanding of the human muscular system. The objective is to further enhance the student's ability to prepare their own physical fitness program at any time in their life and to assist others based upon sound physiological and bio-mechanical principles.

Disciplines • Educational Programs • Course Descriptions

350-3 WEIGHT TRAINING III (CSU) 1 UNIT

Prerequisite: Kin 350-2 | Lecture .5 hours, Lab 2.5 hrs
Weight Training III provides a higher level of weightlifting skills and knowledge, including enhanced spotting techniques, enhanced lifting techniques and an introduction to more advanced exercises used in a weight training program. An increased emphasis will be placed in the knowledge, understanding, value and practical application of building muscle strength and endurance. The course will include an increased understanding of the human muscular system. The objective is to further enhance the student's ability to prepare their own physical fitness program at any time in their life and to assist others based upon sound physiological and bio-mechanical principles.

351-1 YOGA I (UC:CSU) 1 UNIT

Prerequisite: None | Lecture .5 hr, Lab 2.5 hrs
This introductory course teaches a 5,000 year old form of mostly isometric poses (asanas), breathing techniques, and meditation. Yoga promotes mental, physical, and spiritual fitness. In addition there are brief lectures covering basic information on hypertension, exercise precautions, body composition and how to live a healthy lifestyle.

351-2 YOGA II (UC:CSU) 1 UNIT

Prerequisite: None | Lecture .5 hr, Lab 2.5 hrs
Yoga II provides a higher level of teaching a 5,000 year old form of mostly isometric poses (asanas), breathing techniques, and meditation. Yoga promotes mental, physical, and spiritual fitness. In addition there are brief lectures covering basic information on hypertension, exercise precautions, body composition and how to live a healthy lifestyle.

351-3 YOGA III (UC:CSU) 1 UNIT

Prerequisite: None | Lecture .5 hr, Lab 2.5 hrs
Yoga III provides a higher level of teaching a 5,000 year old form of mostly isometric poses (asanas), breathing techniques, and meditation. Yoga promotes

mental, physical, and spiritual fitness. In addition there are brief lectures covering basic information on hypertension, exercise precautions, body composition and how to live a healthy lifestyle.

387-1 BASKETBALL I (CSU) 1 UNIT

Prerequisite: None | Lecture .5 hr, Lab 2.5 hrs
Designed to introduce students to the fundamental aspects of basketball such as terminology, passing, dribbling, shooting and basic game strategies. The course will emphasize the introductory level of basketball skills and basic fitness development.

387-2 BASKETBALL II (CSU) 1 UNIT

Prerequisite: Kin 387-1
Lecture 0.5 hr, Lab 2.5 hrs
Designed to introduce beginning levels of basketball skills such as passing, shooting, defense and rebounding. The course will introduce rules, proper etiquette, terminology, and the components of fitness at a beginning level. Additional skills will include learning a proper lay up at the beginning level.

185 DIRECTED STUDY (CSU) 1 UNIT

Provides opportunity for in-depth study of a chosen area of Kinesiology on a contract basis, under the direction of a supervising instructor.

KINESIOLOGY ATHLETICS HEALTH / KINESIOLOGY / ATHLETICS

FACULTY: Leslie Milke, Chair
Cindy Cooper, Vice Chair | Joe Cascione | Steve Ruys

503 INTERCOLLEGIATE ATHLETICS - BASEBALL (UC:CSU) 3 UNITS RPT 3

Prerequisite: None | Lab 10 hrs
Intercollegiate baseball team. It offers advanced baseball skills and techniques. It provides an opportunity to learn the fine skills and strategies needed to compete at the collegiate level. The

course also provides additional exposure to students interested in articulating to four-year colleges or professional baseball programs.

511 INTERCOLLEGIATE ATHLETICS - SOCCER (UC:CSU) 3 UNITS RPT 3

Prerequisite: None | Lab 10 hrs
Course teaches advanced soccer skills and techniques for the intercollegiate soccer team. It provides an opportunity to learn the fine skills and strategies needed to compete at the collegiate level. The course also provides additional exposure to students interested in articulating to four-year colleges or professional soccer programs.

512 INTERCOLLEGIATE ATHLETICS-SOFTBALL (UC:CSU) 3 UNITS RPT 3

Prerequisite: None | Lab 10 hrs
Teaches advanced softball skills and techniques and is geared toward the intercollegiate softball team members. It provides an opportunity to learn the fine skills and strategies needed to compete at the collegiate level. The course also provides additional exposure to students interested in articulating to four-year colleges or professional softball programs.

516 INTERCOLLEGIATE ATHLETICS - VOLLEYBALL (UC:CSU) 3 UNIT RPT 3

Prerequisite: None | Lab 10 hrs
Intercollegiate volleyball team. It offers advanced volleyball skills and techniques. It provides an opportunity to learn the fine skills and strategies needed to compete at the collegiate level. The course also provides additional exposure to students interested in articulating to four-year colleges or professional volleyball programs.

552 INTERCOLLEGIATE SPORTS - CONDITIONING & SKILLS TRAINING (UC:CSU) 1 UNIT RPT 3

Prerequisite: None | Lab 3 hrs
Training techniques for the intercollegiate student athlete. The following areas are emphasized: the

analysis and training of athletic skills, the analysis of offensive and defensive systems, physical conditioning, strength training and aerobic conditioning.

557 INTERCOLLEGIATE (CSU) 1 UNIT RPT 3
BASEBALL - FITNESS & SKILLS TRAINING

Prerequisite: None | Lab 3 hrs

This course is designed for the student athlete and provides an advanced strength and conditioning program specific to baseball with emphasis on skills, fundamentals, injury prevention, and safety. The student also learns strategic play necessary for competition at advanced levels.

558 INTERCOLLEGIATE SOCCER (CSU) 1 UNIT RPT 3
FITNESS & SKILLS TRAINING

Prerequisite: None | Lab 3 hrs

Student-athlete will be provided an advanced strength and conditioning program specific to soccer with emphasis on skills, fundamentals, injury prevention, and safety. The student also learns strategic play necessary for competition at advanced levels.

563 INTERCOLLEGIATE (CSU) 1 UNIT RPT 2
VOLLEYBALL-FITNESS & SKILLS TRAINING

Prerequisite: None | Lab 3 hrs

Designed for the student athlete. It is intended to provide focused strength and conditioning and flexibility exercises, emphasize safety and injury prevention and present new rules and game plays for volleyball.

564 INTERCOLLEGIATE (CSU) 1 UNIT RPT 3
SOFTBALL-FITNESS & SKILLS TRAINING

Prerequisite: None | Lab 3 hrs

Designed for the student athlete and provides an advanced strength and conditioning program specific to softball, emphasizing injury prevention and safety. The goal of this class is to improve general fitness and strength and to increase explosiveness and speed. The student also learns strategic plays necessary for competition at advanced levels.

KINESIOLOGY MAJOR *HEALTH / KINESIOLOGY / ATHLETICS*

FACULTY: Leslie Milke, Chair
Cindy Cooper, Vice Chair | Joe Cascione | Steve Ruys

100 INTRODUCTION TO (UC: CSU) 3 UNITS
KINESIOLOGY

Prerequisite: None | Lecture 3 hrs

An introduction to the interdisciplinary approach to the study of human movement. Using a holistic and integrated approach, students will examine the multi-faceted field of Kinesiology. Students will explore strategies aimed at creating success as they pursue their university and professional goals.

LAW *BUSINESS / LAW*

FACULTY: Vilma Bernal, Chair
David Jordan, Vice Chair

EDUCATIONAL PROGRAMS

A paralegal is qualified by education, training, or work experience to work for a law office, corporation, governmental agency, or other entity, performing specifically delegated substantive legal work for which a lawyer is responsible. Paralegals are also referred to as Legal Assistants in some legal settings.

The curriculum provides students with practical legal skills enabling them to draft legal documents with minimum supervision. Students also are familiarized with fundamental concepts of substantive areas such as torts and business law. In addition, emphasis is placed on the development of effective written and oral communication skills, team work, critical thinking skills, computer proficiency, and legal research techniques. Legal theory

and related practical applications are integrated throughout the program. Students also learn how to manage practical ethical dilemmas commonly encountered as working paralegals.

The Los Angeles Mission College Paralegal Studies Program has been approved by the Board of Governors of the L.A. Community Colleges, and has been graduating paralegals/legal assistants since 1987. Its curriculum is continuously updated to ensure that it is a quality paralegal program.

The Paralegal Program at L.A. Mission College exceeds the mandate of 24 semester units for paralegal education requirements under the Business and Professions Code sections 6400 and 6450 in the State of California. Earning a Certificate of Achievement from the L.A. Mission College Paralegal Studies Program (36 units/12 law classes) complies with the educational requirements of California law (<http://profj.us/newlaw>) regulating paralegals in the State of California.

The student may choose an Associate in Arts Degree in Legal Assisting/Paralegal or a Certificate of Achievement.

Since Paralegals may find work in other career fields, electives for the AA Degree should be considered in accounting, business, finance, and/or real estate, although none of these disciplines is specifically required. The following classes are required for both career options.

NOTE: A minimum of 60 units and a cumulative GPA of 2.0 or higher must be completed to earn the Associate in Arts Degree. Always consult a counselor for information on graduation requirements, residency requirements and transfer information.

Disciplines • Educational Programs • Course Descriptions

ASSOCIATE IN ARTS/ CERTIFICATE OF ACHIEVEMENT Legal Assisting (Paralegal)

For General Education Requirements, see page 73

Program Learning Outcomes –

Upon completion, students will be able to:

- Correctly use legal terminology, and interpret the fundamentals of the legal system, its processes, deadlines and procedures;
- Conduct effective legal research;
- Effectively communicate in writing including the preparation of legal documents and court forms, and perform general paralegal tasks;
- Apply the appropriate rules of ethics and of professional conduct governing lawyers and paralegals in legal matters and in all employment settings.

REQUIRED COURSES

		UNITS
Law 1	Business Law I	3
Law 2	Business Law II	3
Law 10	Introduction to Legal Assistant I	3
Law 11	Introduction to Legal Assistant II	3
Law 12	Tort Law & Claims Investigation	3
Law 13	Wills, Trusts & Probate Administration	3
Law 16	Civil & Criminal Evidence	3
Law 17	Legal Writing	3
Law 18	Marriage & Family Law	3
Law 19	Property & Creditor Rights	3
Law 20	Basic Probate Procedure	3
Law 34	Legal Research Lab	3

Total 36

RECOMMENDED COURSES

CAOT 82	Microcomputer Software Survey	3
English 101	College Reading & Composition I	3

1 BUSINESS LAW I (UC:CSU) 3 UNITS

Prerequisite: None | Lecture 3 hrs

Study of the fundamental principles of law as they apply in the business world by examining legal rights and remedies, business torts and crimes, contracts, agency, employment, and negotiable instruments.

2 BUSINESS LAW II (UC:CSU) 3 UNITS

Prerequisite: None | Lecture 3 hrs

Further study of the fundamental principles of law as they apply in the business world. Examines bailment, the rights and liabilities of agent, principle and liabilities of agent, principle and third parties, partnerships, corporations, stockholders, negotiable instruments and securities.

10 INTRODUCTION TO LEGAL ASSISTANT I (CSU) 3 UNITS

Prerequisite: None | Lecture 3 hrs

Introductory study of law including an overview of the system of American law, legal reasoning, case law, statutes, the courts, court procedures, constitutional law, torts, intellectual property, criminal law, administrative law, international law, employment law and environmental law.

11 INTRODUCTION TO LEGAL ASSISTANT II (CSU) 3 UNITS

Prerequisite: None | Lecture 3 hrs

Study of civil and criminal procedures. Emphasis is on parties and jurisdiction, pleadings, discovery, pre-trial and trial preparation, appeal, enforcement of judgments, and alternative dispute resolution.

12 TORT LAW & CLAIMS INVESTIGATION (CSU) 3 UNITS

Prerequisite: None | Lecture 3 hrs

Study of the law of torts including intentional torts, privileges, negligence, joint & several Liability, damages, defenses, liability without fault, product liability, strict liability, nuisance, trespass, economic torts, misuses of legal process, defamation, invasion of privacy, insurance, and workers' compensation.

13 WILLS, TRUSTS & PROBATE ADMINISTRATION (CSU) 3 UNITS

Prerequisite: None | Lecture 3 hrs

Study of the law of wills and trusts, including simple wills, codicils, trust forms, living trusts, pour over wills, advance directives, powers of attorney, guardianship, conservatorship, caretakers, basic estate planning, life estates, disposition of property outside probate, tax issues, and life insurance trusts.

16 CIVIL & CRIMINAL EVIDENCE (CSU) 3 UNITS

Prerequisite: None | Lecture 3 hrs

Study of the rules of civil and criminal evidence and the admissibility of such evidence in court including relevancy, hearsay, hearsay exceptions, character evidence, habit and custom, witness & competency, impeachment, authentication and identification of documents, constitutional restraints, and common law privileges. Students analyze evidentiary objections to trial transcripts, and other legal documents.

17 LEGAL WRITING (CSU) 3 UNITS

Prerequisite: None | Lecture 3 hrs

Study of legal drafting and writing including writing case briefs, demand letters, legal memoranda, motions, pleadings, and writing a legal research paper.

18 MARRIAGE & FAMILY LAW (CSU) 3 UNITS

Prerequisite: None | Lecture 3 hrs

Study of marriage and family law with emphasis on dissolution of marriage, California community property laws, jurisdiction, forms completion, calendaring, discovery, support and custody issues, restraining orders, and domestic disputes.

19 PROPERTY & CREDITOR RIGHTS 3 UNITS

Prerequisite: None | Lecture 3 hrs

Study of property and creditor rights including real and personal property, joint tenancy, leases, deeds, escrows, deeds of trust, the system of recording and search of public documents, bankruptcy laws

and forms, landlord-tenant, secured transactions, collateral, purchase money security interests, liens, attachments, garnishments, and other creditor's remedies.

20 BASIC PROBATE PROCEDURES (CSU) 3 UNITS
Prerequisite: None | Lecture 3 hrs

Study of the fundamental principles and methods of fact gathering, office procedures, and required court work involved in the handling of probates of both testate and intestate decedents, as well as the administration of estates in California Probate Courts.

34 LEGAL RESEARCH LABORATORY 3 UNITS
Prerequisite: None | Lecture 3 hrs

Study of legal research including key search terms, precedents, citation format, finding cases, constitutions, statutes, regulations, ordinances, conducting, expanding and updating both federal and California legal research and reporting research results in various formats.

LEARNING SKILLS

ESL / DEV COM / LEARNING SKILLS

FACULTY: Gary Prostack, Chair

4 THE MECHANICS OF SPELLING (NDA) 1 UNIT

Prerequisite: None | Lab 2 hrs

NOTE: Class is graded pass/no-pass

Based on diagnostic assessment, the student will receive group and individualized spelling instruction designed to improve spelling skills to the level at which the student will be able to succeed in college/vocational coursework.

73 GRAMMAR & WRITING LAB (NDA) 1 UNIT
Prerequisite: None | Lab 3 hrs

NOTE: Class is graded pass/no-pass

This course provides students with an introduction to verb usage and grammar while completing short personal and impersonal writings. Students will have access to online writing labs and will be required to submit written assignments for peer and instructor review.

LIBERAL STUDIES

LIBERAL STUDIES

The Liberal Studies Concentration is designed for students interested in entering the Teaching Profession (Elementary and Special Education). Courses taken within this concentration will satisfy lower-division coursework requirements for Liberal Studies Majors at California State University Northridge as well as at other universities. The required courses for the Liberal Studies – Multiple Subject Teacher Prep Concentration will help prepare students for transfer, but WILL NOT meet all the Liberal Studies requirements for transfer. Please consult with a counselor and the Transfer Center for specific information regarding your intended major at the specific colleges/universities of choice.

NOTE: A minimum of 60 units and a cumulative GPA of 2.0 or higher must be completed to earn the Associate in Arts Degree. Always consult a counselor for information on graduation requirements, residency requirements and transfer information.

ASSOCIATE IN ARTS - Multiple Subject Teacher Preparation

For General Education Requirements, see page 73

Program Learning Outcomes –

Upon completion, students will be able to:

- Synthesize a breadth of knowledge across the range of disciplines included in the major and pursue greater depth in the student's area of specialization;
- Demonstrate the ability to formulate goals for continued learning and inquiry based on a foundation of intellectual curiosity;
- Demonstrate ability to think critically and creatively;
- Demonstrate ability to write and speak clearly, coherently, and thoughtfully.

REQUIRED COURSES		UNITS
Biology 3	Introduction to Biology	4
English 101	College Reading & Composition I	3
PolSci 1	The Government of the U.S.	3
Comm 101	Oral Communication 1	3
ChDev 1	Child Growth & Development	3
Math 215 or Math 227	Principles of Mathematics 1 Statistics	3-4

Total 19-20

and Plan A Graduation Requirements

RECOMMENDED COURSES

History 86	Introduction to World Civilization 1	3
PhysSc 1, 14	Physical Science & Lab	3-4

LIBRARY SCIENCE

LIBRARY

FACULTY: David Garza, Chair

101 LIBRARY RESEARCH METHODS (UC:CSU) 1 UNIT

Prerequisite: None | Lecture 1 hr

Students apply basic steps of the research process to find, organize, evaluate, and cite information from various print and on-line sources, including library databases, catalogs, books, e-books, periodicals, and the Internet.

LINGUISTICS

FOREIGN LANGUAGES

FACULTY: Dr. Jolie Scheib, Chair

1 INTRODUCTION TO LANGUAGE & LINGUISTICS (UC:CSU) 3 UNITS

Prerequisite: None | Lecture 3 hrs

A summary of what is known about human language: the unique nature of human language, its structure, its universality, and its diversity; language in its social and cultural setting; language in relation to other aspects of human inquiry and knowledge.

Disciplines • Educational Programs • Course Descriptions

MANAGEMENT BUSINESS / LAW

FACULTY: Vilma Bernal, Chair

EDUCATIONAL PROGRAMS

This program is designed to meet the needs of 1) employed persons desiring to prepare for supervisory positions, and 2) supervisors and other management personnel who wish to gain knowledge which will enable them either to perform their duties more effectively or to advance to more responsible positions. This course of study was developed with the assistance of our Business Advisory Committee. Typical Positions: Various supervisory and managerial positions in the industrial and commercial community.

NOTE: A minimum of 60 units and a cumulative GPA of 2.0 or higher must be completed to earn the Associate in Arts Degree. Always consult a counselor for information on graduation requirements, residency requirements and transfer information.

ASSOCIATE IN ARTS - Management

For General Education Requirements, see page 73

Program Learning Outcomes –

Upon completion, students will be able to:

- Analyze and apply ethical values and global perspectives while making appropriate decisions related to management problems.
- To assess effective leadership styles, teamwork, and communication skills.

REQUIRED COURSES

Acctg 1	Introductory Accounting I	5
Bus 1	Introduction to Business	3
Bus 5	Business Law I	3
CAOT 32	Business Communications	3
Mgmt 2	Organization and Management Theory	3
Mgmt 13	Small Business Entrepreneurship	3
Mgmt 33	Personnel Management	3
Select one course:		
Econ 1	Principles of Economics I	3
Econ 2	Principles of Economics II	3
Select two courses:		
Bus 172	Global Business	6
Market 21	Principles of Marketing	
Finance 1	Principles of Finance	
CAOT 82	Microcomputer Software Survey in the Office	
Market 22	Green Marketing	

UNITS

REQUIRED COURSES	UNITS	
Mgmt 2	Organization & Management Theory	3
CAOT 31	Business English	3
Bus 38	Business Computations	3
Acctg 21	Bookkeeping & Accounting I	3
Market 21	Principles of Marketing	3
Comm 101	Oral Communication I	3
Mgmt 33	Personnel Management	3
Mktg 31	Retail Merchandising	3
Mgmt 31	Human Relations for Employees	3
CoSci 401	Introduction to Computers & Their Uses	3
or CoSci 430	Microcomputer Applications I	
or CAOT 82	Microcomputer Software Survey in the Office	
		Total 30

Total 32

CERTIFICATE OF ACHIEVEMENT Retail (WACF) Management

Students completing the following program will be awarded a Certificate of Achievement. This certificate is designed primarily for those students who have a limited amount of time to pursue their career goals and wish to specialize in a particular aspect of Management. They may seek upward mobility in their present job, or they may desire to prepare themselves for a new career.

Program Learning Outcomes –

Upon completion, students will be able to:

- Use technology, theoretical concepts, and analytical skills in retail related problem-solving and decision-making;
- Demonstrate effective leadership, teamwork, and communication skills.

2 ORGANIZATION & MANAGEMENT THEORY (CSU) 3 UNITS

Prerequisite: None | Lecture 3 hrs

A beginning course in theory and practice of management and organization. It gives a realistic account of what managers actually do and what they face. It presents various theories of management and organization. The functions of management with special emphasis on foreign operations and future trends in management are analyzed.

13 SMALL BUSINESS ENTREPRENEURSHIP (CSU) 3 UNITS

Prerequisite: None | Lecture 3 hrs

This course presents a systematic approach to startup and management of small business operations. It covers personal evaluation, pre-ownership preparation, management and leadership, financing, location, record keeping, employees, purchasing, advertising, sales and credit, and emphasizes adequate planning and preparation for success.

31 HUMAN RELATIONS FOR EMPLOYEES (CSU) 3 UNITS

Prerequisite: None | Lecture 3 hrs

Students will apply the psychological and sociological principles to the study of human relations in business and industry. The students will examine case studies and teamwork scenarios. Students will identify communication styles, self-esteem, ethics, attitude and motivation, self-disclosure, emotional balance, leadership strategies, work force diversity, and professional presence.

33 PERSONNEL MANAGEMENT (CSU) 3 UNITS

Prerequisite: None | Lecture 3 hrs

Consists of a critical examination of the principles, methods, and procedures related to the effective utilization of human resources in organizations. Includes the management of employment recruiting, testing, selection and placement; job evaluation; wage and salary administration; labor relations and communication; performance evaluation; promotion and transfer; discipline, motivation, and morale.

185 DIRECTED STUDY (CSU) 1 UNIT

Provides opportunity for in-depth study of a chosen area of Management on a contract basis, under the direction of a supervising instructor. Credit limit:

285 DIRECTED STUDY (CSU) 2 UNITS

Provides opportunity for in-depth study of a chosen area of Management on a contract basis, under the direction of a supervising instructor.

385 DIRECTED STUDY (CSU) 3 UNITS

Provides opportunity for in-depth study of a chosen area of Management on a contract basis, under the direction of a supervising instructor.

MARKETING

BUSINESS / LAW

FACULTY: Vilma Bernal, Chair

EDUCATIONAL PROGRAM

The courses in the Marketing curriculum are designed for those students who wish to enter the field of marketing. The program not only provides training for a beginning career as a manufacturer's, wholesale or retail salesperson, retail buyer, and advertising account manager, but also helps the student see marketing through the eyes of the marketing manager.

The curriculum listed below provides an in-depth understanding of how to interact with customers, competition, suppliers, distributors and government. It is also designed to encourage the student to add breadth to the program by completing all recommended courses.

NOTE: A minimum of 60 units and a cumulative GPA of 2.0 or higher must be completed to earn the Associate in Arts Degree. Always consult a counselor for information on graduation requirements, residency requirements and transfer information.

ASSOCIATE IN ARTS - Marketing

For General Education Requirements, see page 73

Program Learning Outcomes -

Upon completion, students will be able to:

- Use marketing research tools/methods to conduct marketing research projects;
- Apply ethical values, global awareness and technological skills to identify marketing problems and issues and make appropriate decisions;
- Apply critical thinking skills to formulate viable solutions to marketing problems.

REQUIRED COURSES		UNITS
Acctg 1 or Acctg 21+Acctg 22	Introductory Accounting I	5-6
Business 1	Introduction to Business	3
Bus 5 or Law 1	Business Law I	3
CAOT 31	Business English	3
CAOT 32	Business Communications	3
CAOT 82	Microcomputer Software Survey in the Office	3
Econ 1	Principles of Economics I	3
Finance 1	Principles of Finance	3
Finance 8	Personal Finance & Investments	3
Market 21	Principles of Marketing	3
Mgmt 2	Organization & Management Theory	3
Mgmt 13	Small Business Management	3
Mgmt 31	Human Relations for Employees	3
		Total 41-42

21 PRINCIPLES OF MARKETING (CSU) 3 UNITS

Prerequisite: None | Lecture 3 hrs

Designed to provide the student with a comprehensive introduction to concepts and principles of marketing from a marketing manager perspective. It examines the problems and decisions that marketing managers encounter in selecting an attractive target market.

22 GREEN MARKETING (CSU) 3 UNITS

Advisory: English 28 | Lecture 3 hrs

Analyzes emerging green marketing trends with an overview of key issues and challenges involved in sustainable marketing that relate to product development, product life cycle, marketing strategies, channels, communication and practices within the context of corporate social responsibility and environmental sustainability.

31 RETAIL MERCHANDISING (CSU) 3 UNITS

Prerequisite: None | Lecture 3 hrs

Course covers the retail operation including a study of store location, layout, organization, merchandise buying, pricing, stock planning and retail sales promotion. Personnel duties and responsibilities are also studied including the tasks of all personnel.

Disciplines • Educational Programs • Course Descriptions

MATHEMATICS

MATHEMATICS / COMPUTER SCIENCE

FACULTY: Debby Wong, Chair | Robert Smazenka, Vice Chair
Carole Akl | Roula Dakdouk | Tigran Mkrtchyan | Bamdad Samii Emil
Sargsyan | Ryan Yamada | Yoon Yun

Program Learning Outcomes - Upon completion, students will be able to:

- Demonstrate proficiency in solving problems using mathematical reasoning and drawing inferences using data analysis.

MATHEMATICS COURSE SEQUENCES:

A. GE Transfer and AA/AS Degree Track

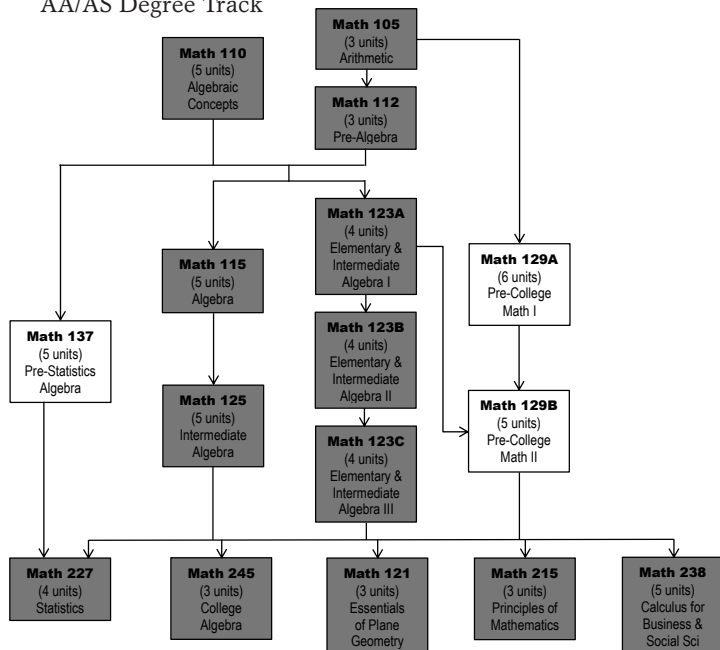

B. Advanced Mathematics Sequence Track

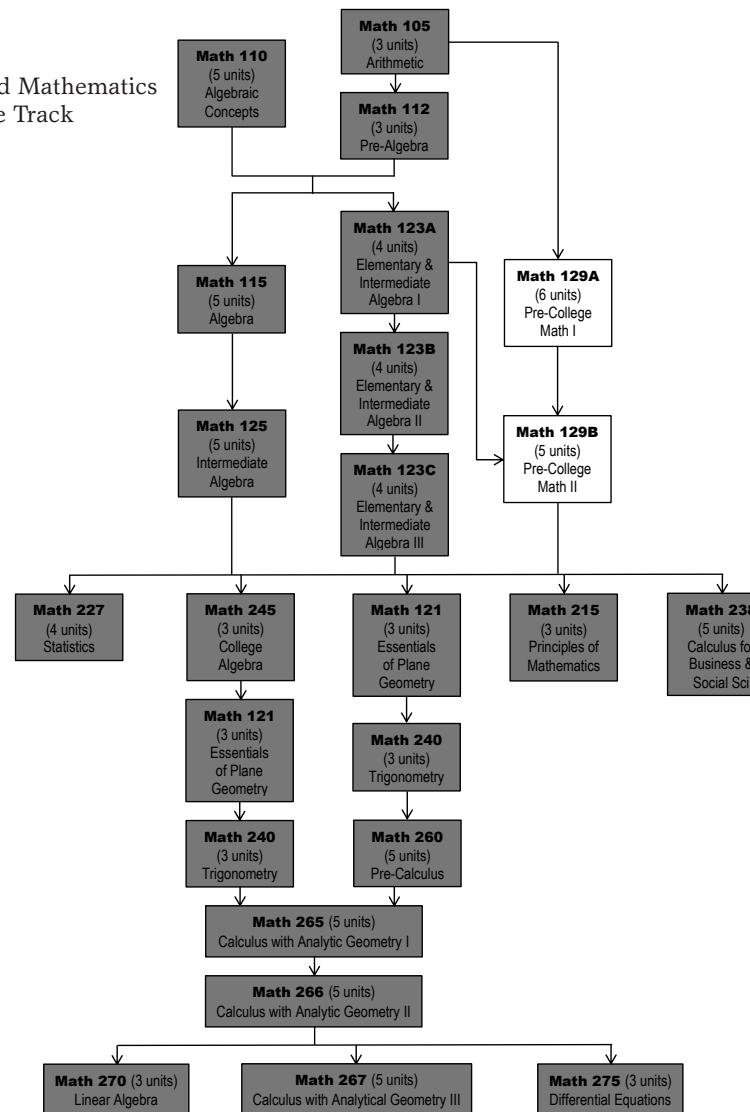

NOTE: A minimum of 60 units and a cumulative GPA of 2.0 or higher must be completed to earn the Associate in Arts Degree. Always consult a counselor for information on graduation requirements, residency requirements and transfer information.

ASSOCIATE IN ARTS - Mathematics

For General Education Requirements, see page 73

Program Learning Outcomes –

Upon completion, students will be able to:

- Demonstrate proficiency in solving problems using mathematical reasoning and drawing inferences using data analysis;
- Demonstrate proficiency in extracting, analyzing and testing data, in order to draw scientifically-based inferences and conclusions.

EDUCATIONAL PROGRAM

In order to complete a major in Mathematics, students must complete a minimum of 18 units from among the following courses. Among the 18 units must be 5 units from Mathematics 266 or 267 to meet the major requirements.

REQUIRED COURSES

Math 266	Calculus with Analytic Geometry II	5
or Math 267	Calculus with Analytic Geometry III	

Select a minimum of 13 units from the following courses: UNITS

Math 121	Essentials of Plane Geometry	3
Math 215	Principles of Mathematics I	3
Math 227	Statistics	4
Math 238	Calculus for Business & Social Sciences	5
Math 240	Trigonometry	3
Math 245	College Algebra	3
Math 260	Pre-calculus	5
Math 265	Calculus with Analytic Geometry I	5
Math 270	Linear Algebra	3
Math 275	Ordinary Differential Equations	3
Math 285 or Math 385	Directed Study (see Note 1)	3

NOTE 1: A maximum of 3 units from math 285 and 385 may be applied toward the degree. In order for these units to apply, a detailed plan of study must be presented and approved by the Mathematics Department. Only advanced post-calculus topics will be considered appropriate for directed study toward the degree.

Associate in Science for Transfer (AS-T) Mathematics

Program Learning Outcomes –

Upon completion, students will be able to:

- Demonstrate proficiency in solving problems using mathematical reasoning and drawing inferences using data analysis;

- Demonstrate proficiency in extracting, analyzing and testing data, in order to draw scientifically-based inferences and conclusions;
- Transfer to an undergraduate program at the university level in the field of mathematics.

REQUIRED CORE

Math 265	Calculus with Analytic Geometry I	UNITS	5
Math 266	Calculus with Analytic Geometry II		5
Math 267	Calculus with Analytic Geometry III		5

LIST A: Select one (1) course

Math 270	Linear Algebra	3
Math 275	Ordinary Differential Equations	

LIST B: Select one (1) course

Math 227	Statistics	3-4
CoSci 439	Programming in C	
or CoSci 440	Programming in C ++	
or Any LIST A course not already used		

Total 21-22

NOTE: A minimum of 60 units and a cumulative G.P.A. of 2.0 or higher must be completed to earn the Associate in Science for Transfer. Always consult a counselor for information on graduation requirements, residency requirements and transfer information.

105 ARITHMETIC (NDA) 3 UNITS

Prerequisite: None | Lecture 3 hrs

Reviews operations and applications of arithmetic, including whole numbers, fractions, decimals, and percents. Additional topics of ratios and proportion and measurement.

110 INTRO TO ALGEBRAIC CONCEPTS (NDA) 3 UNITS

Prerequisite: None | Lecture 4 hours, Lab 2 hrs

Covers the fundamentals of arithmetic through beginning algebra skills that are essential for Elementary Algebra. Topics include operations on whole numbers, fractions, decimals, and integers; order of operations; ratios, proportions, percents, and applications; perimeter, area, and volume applications; metric and English conversions; and simple algebraic expressions and equations. Basic word problems that embody these concepts are included throughout the course. Students may not earn credit for both Math 110 and Math 112. This course has a laboratory component.

112 PRE-ALGEBRA (NDA) 3 UNITS

Prerequisite: Math 105 | Lecture 3 hrs

Bridges the gap between arithmetic and algebra. Topics include a review of arithmetic and an introduction to fundamental algebraic concepts.

115 ELEMENTARY ALGEBRA 5 UNITS

Prerequisite: Math 110 or Math 112 | Lecture 5 hrs

Explores the concepts of algebra, including signed numbers, exponents, linear equations, graphs, and quadratic equations. It also contains techniques for interpreting and solving verbal problems related to the above topics.

121 ESSENTIALS OF PLANE GEOMETRY 3 UNITS

Prerequisite: Math 123C or Math125

Lecture 3 hrs

Covers the definitions, axioms, and theorems of geometry relating to angles, lines, circles, polygons, and polyhedra. It also provides an introduction to formal proofs, logic, and construction methods with straight-edge and compass.

123 ELEMENTARY & INTERMEDIATE ALGEBRA 12 UNITS

Prerequisite: Math 112 | Lecture 9 hrs, Lab 6 hrs

Course provides a combined study of elementary and intermediate algebra topics, fulfilling any intermediate algebra requisite. Topics covered include linear and quadratic equations and inequalities, graphing, polynomials, factoring, radicals, conics, functions, exponential and logarithms. Course has a computer lab component. Course equivalent to Math 115 and 125.

123A ELEMENTARY & INTERMEDIATE ALGEBRA I 4 UNITS

Prerequisite: Math 110 or Math 112

Lecture 3 hrs, Lab 2 hrs

First of three modules for Math 123, covering topics from Elementary Algebra, including properties of real numbers; linear equations and inequalities; polynomials; factoring first- and second-degree expressions; application problems; graphing. Course has a computer lab component.

Disciplines • Educational Programs • Course Descriptions

123B ELEMENTARY & INTERMEDIATE ALGEBRA II 4 UNITS

Prerequisite: Math 123A | Lecture 3 hrs, Lab 2 hrs

Second of three modules for Math 123, covering topics from Elementary and Intermediate Algebra, including solving rational equations; systems of equations; quadratic equations; applications; radicals; rational exponents. Course has a computer lab component.

123C ELEMENTARY & INTERMEDIATE ALGEBRA III 4 UNITS

Prerequisite: Math 123B | Lecture 3 hrs, Lab 2 hrs

Third of three modules for Math 123, covering topics from Intermediate Algebra, including operations on functions; complex numbers; conic sections; logarithms and exponential functions. Course has a computer lab component.

125 INTERMEDIATE ALGEBRA 5 UNITS

Prerequisite: Math 115 or 123B | Lecture 5 hrs

Explores polynomials, rational expressions, quadratic functions, radicals, complex numbers, absolute value functions, exponential functions, logarithmic functions, systems of equations (two and three variables), inequalities, function operations and conics. Covers strategies for interpreting and solving application problems that can be modeled using the above topics along with graphing techniques for functions.

137 PRE-STATISTICS ALGEBRA 5 UNITS

Prerequisite: Math 110 or Math 112

Lecture 5 hrs, Lab 1 hr

NOTE: This course will not meet Associate Degree and Graduation requirements.

Introduces algebra topics and the basic elements of exploratory data analysis. Topics in the course include: solving algebraic equations, simplifying algebraic expressions, data analysis, sample statistics and graphs, measures of central tendency and spread, functions and their graphs, probability, sequences and series, and exponential and logarithmic functions. This class is intended as preparation for students who wish to take Statistics. Students wishing to take other 200 level math courses will require Math 125 and should consult the college catalog for prerequisites.

215 PRINCIPLES OF MATHEMATICS I (UC:CSU) 3 UNITS

Prerequisites: Math 123C or Math 125

Advisory: Math 121 | Lecture 3 hrs

Primarily for students who plan to teach arithmetic in elementary schools, this course focuses on the development of quantitative reasoning skills through in-depth, integrated explorations of topics in mathematics, including real number systems and subsystems. Emphasis is on comprehension and analysis of mathematical concepts and applications of logical reasoning.

227 STATISTICS (UC:CSU) 4 UNITS

Prerequisite: Math 123C or Math 125

Lecture 4 hrs

Course covers descriptive statistics, basic probability theory and inferential statistics with emphasis on understanding statistics methods. Topics include summarizing data; descriptive statistics; probability; discrete distributions; continuous distributions; sampling distributions; estimation and confidence intervals; hypothesis testing and inference; correlation and linear regression; analysis of variance (ANOVA), chi-square and t-tests; applications using data from disciplines including business, social sciences, psychology, life science, health science, and education. The use of technology such as Excel, Minitab, or StatCrunch is integrated into the course to perform statistical analysis and the relevance of the statistical findings is interpreted.

238 CALCULUS FOR BUSINESS & SOCIAL SCIENCES I (UC:CSU) 5 UNITS

Prerequisite: Math 123C or Math 125

Advisory: Math 245 | Lecture 5 hrs

A course in Calculus intended for Business and Social Science majors. The following topics and their business applications are included: polynomial, rational, exponential and logarithmic functions; differentiation and integration; integration by parts; numerical integration; improper integrals; multivariable calculus.

240 TRIGONOMETRY (CSU) 3 UNITS
Prerequisite: Math 121 or Math 120 and 125
or Math 123C | Lecture 3 hrs

Introduces trigonometric functions, their graphs, inverses, and fundamental identities. Trigonometric equations are solved. The laws of sines and cosines; vectors; scalar and vector products are introduced. Polar coordinates and equations are introduced and used to represent complex numbers.

245 COLLEGE ALGEBRA (UC:CSU) 3 UNITS
Prerequisite: Math 123C or Math 125
Lecture 3 hrs

A college-level course in algebra. Topics include the properties of real numbers, relations, functions and their graphs, matrices and determinants, complex numbers, theory of equations, sequences and series, permutations, combinations, and probability.

260 PRE-CALCULUS (UC:CSU) 5 UNITS
Prerequisite: Math 240 | Lecture 5 hrs

Provides topics essential for a comprehensive background for the calculus sequence: functional analysis, analytic geometry, theory of equations, induction, sequences and series, trigonometry and polar coordinates.

265 CALCULUS WITH ANALYTIC GEOMETRY I (UC:CSU) 5 UNITS
Prerequisites: Math 260 or Math 240 and 245
Lecture 5 hrs

The first course in differential and integral Calculus of a single variable. Topics include algebraic and transcendental functions; limits and continuity; techniques and applications of differentiation and integration; curve sketching and Fundamental Theorem of Calculus. Primarily for Science, Technology, Engineering & Math majors.

266 CALCULUS WITH ANALYTIC GEOMETRY II (UC:CSU) 5 UNITS
Prerequisite: Math 265 | Lecture 5 hrs

The second course in differential and integral Calculus of a single variable. Topics include differentiation and integration of transcendental functions, polar coordinates, specialized methods of integration, parametric equations, and infinite series. Primarily for Science, Technology, Engineering & Math Majors

267 CALCULUS WITH ANALYTIC GEOMETRY III (UC:CSU) 5 UNITS
Prerequisite: Math 266 | Lecture 5 hrs

Third course of calculus. Includes solid analytic geometry, partial differentiation, multiple integration, vector analysis, and an introduction to differential equations.

270 LINEAR ALGEBRA (UC:CSU) 3 UNITS
Prerequisite: Math 266 | Lecture 3 hrs

Covers vector spaces, linear transformation, matrices, matrix algebra, determinants, eigen vectors and eigen values.

272 METHODS OF DISCRETE MATHEMATICS (CSU) 5 UNITS
Prerequisite: Math 266 and Co Sci 440 and 452
Lecture 5 hrs

Introduction to the discrete structures used in Computer Science. Topics include sets, relations, functions and logic along with formal methods of proof such as contradiction, contrapositive, induction, diagonalization, recursion, and the Pigeonhole principle. These ideas and methods are developed by writing programs to solve problems from combinatorics and counting, elementary number theory, and graph theory. Topics from map coloring, complexity, and cryptography are also discussed.

275 ORDINARY DIFFERENTIAL EQUATIONS (UC:CSU) 3 UNITS

Prerequisite: Math 266 | Lecture 3 hrs

An introduction to ordinary differential equations including both quantitative and qualitative methods as well as applications from a variety of disciplines. Introduces the theoretical aspects of differential equations, including establishing when solution(s) exist, and techniques for obtaining solutions, including, series solutions, variation of parameters, Laplace transforms and linear systems.

185 DIRECTED STUDY (CSU) 1 UNIT
Directed studies on a contract basis under the supervision of an instructor.

285 DIRECTED STUDY (CSU) 2 UNITS
Directed studies on a contract basis under the supervision of an instructor.

385 DIRECTED STUDY (CSU) 3 UNITS
Directed studies on a contract basis under the supervision of an instructor.

MICROBIOLOGY

LIFE SCIENCES

FACULTY: J. Michael Reynolds, Chair
Dr. Stephen Brown | Dr. Angela Echeverri

20 GENERAL MICROBIOLOGY (UC:CSU) 4 UNITS
Prerequisites: English 28 or ESL 8, and
Chemistry 51 or 65, and Biology 3 or 5
Lecture 3 hrs, Lab 3 hrs

Examines microbiological principles related to the morphology, metabolism and genetics of bacteria and distinguishing characteristics of viruses, protozoa, fungi, and multicellular parasites, with applications to human disease. It is intended principally for allied health majors with 3 hours of lab each week.

Disciplines • Educational Programs • Course Descriptions

MULTIMEDIA STUDIES

ARTS, MEDIA & PERFORMANCE

FACULTY: Deborah Paulsen, Chair
Curtis Stage, Vice-Chair | Huy (John) Huynh

EDUCATIONAL PROGRAMS

ASSOCIATE IN ARTS

Students who complete Foundation and Advanced courses in one (1) Area of Concentration (37 units) and the General Education Requirements under Plan B will earn an Associate in Arts Degree in Multimedia. Consult the Graduation Requirements section of this catalog for the additional requirements. It is highly recommended that students interested in a career in Multimedia prepare for transferring to a four-year university or art school. Please contact the Transfer Center for requirements. Students who complete one of the Areas of Concentration will earn an AA Degree with an emphasis in that area.

NOTE: A minimum of 60 units and a cumulative GPA of 2.0 or higher must be completed to earn the Associate in Arts Degree. Always consult a counselor for information on graduation requirements, residency requirements and transfer information.

MULTIMEDIA: Animation & 3D Design Concentration

For General Education Requirements, see 74

Program Learning Outcomes –

Upon completion, students will be able to:

- Apply the elements and principles of design with competent skill and technique with computer based media;
- Present an animation containing the elements of a fully developed narrative or experimental story;
- Plan and produce a storyboard and three-part story structure utilizing the principles of sequential art that leads to a fully developed animation using the computer software.

REQUIRED FOUNDATION COURSES

Art 201	Drawing I
Art 204	Life Drawing I
Multimd 100	Introduction to Computer Applications
Multimd 110	Visual Communication
Multimd 210	Digital Editing
Multimd 220	Illustration for Multimedia

REQUIRED COURSES

Multimd 300	Design for 3D Computer Applications
Multimd 310	Interactive Multimedia
Multimd 320	Web Design
Multimd 400	Introduction to Experimental Animation
Multimd 402	Animation Workshop
Multimd 430	Computer Applications for 3D Animation
Multimd 500	Multimedia Laboratory

UNITS

3
3
3
3
3
3
1

Total 37

NOTE: This Program is also available as a 37-unit Certificate.

MULTIMEDIA: Graphic & Web Design Concentration

For General Education Requirements, see 74

Program Learning Outcomes –

Upon completion, students will be able to:

- Apply the elements and principles of design with competent skill and technique with computer based media;
- Demonstrate application of basic design principles with an emphasis on illustration, graphic layouts, logo creation, font creation, web navigation, web page layout and the ability to apply these principles to a specific aesthetic intent, including a functional knowledge of the traditions, conceptual modes, and evolutions of the discipline;
- Analyze visual forms and their aesthetic functions and basic design principles, with attention to such areas as design, color, and lighting.

REQUIRED FOUNDATION COURSES

Art 201	Drawing I
Art 501	Beginning Two-Dimensional Design
Photo 10	Beginning Photography
Multimd 100	Introduction to Computer Applications
Multimd 110	Visual Communication
Multimd 200	Digital Imaging

REQUIRED COURSES

Multimd 220	Illustration for Multimedia
Multimd 240	Graphic Design for Multimedia
Multimd 310	Interactive Multimedia
Multimd 320	Web Design
Multimd 340	Vector Graphics
Multimd 350	Advanced Web Design
Multimd 500	Multimedia Laboratory

UNITS

3
3
3
3
3
3
1

Total 37

NOTE: This Program is also available as a 37-unit Certificate.

MULTIMEDIA: Video Production Concentration

For General Education Requirements, see 74

Program Learning Outcomes –

Upon completion, students will be able to:

- Apply the elements and principles of production design with competent skill and technique with production equipment such as cameras and computer editing software;
- Analyze historical, cultural, and aesthetic factors that led to rise of popular narrative and documentary filmmaking and how its model of production became the dominant form practiced by popular cinemas worldwide;
- Recognize, articulate, and judge the visual, verbal, and audio conventions through which images, words, and sounds make meaning in film and media texts.

REQUIRED FOUNDATION COURSES		UNITS
Theater 100	Introduction to Theater	3
or Theater 200	Introduction to Acting	
Cinema 3	History of Motion Pictures & Television	3
or Cinema 4	History of Documentary Film	
Photo 10	Beginning Photography	3
Multimd 100	Introduction to Computer Applications	3
Multimd 110	Visual Communication	3
Multimd 200	Digital Imaging	3
REQUIRED COURSES		
Multimd 210	Digital Editing	3
Multimd 600	Story, Script and Screen	3
Multimd 610	Introduction to Digital Video Production	3
Multimd 620	Digital Audio	3
Multimd 630	Digital Video Production Footage Acquisition	3
Multimd 640	Digital Video Production Digital Editing	3
Multimd 500	Multimedia Laboratory	1
		Total 37

NOTE: This Program is also available as a 37-unit Certificate.

CERTIFICATE OF ACHIEVEMENT

Students will receive a Certificate for the successful completion of any of the three 37-unit programs above. Certificate requirements are the same as Area of Concentration units. For additional information, consult a counselor or a faculty member in Multimedia.

CERTIFICATE OF ACCOMPLISHMENT

Students will receive a Certificate of Accomplishment for the successful completion of any of the following 16-unit programs. For additional information, consult a counselor or a faculty member in Multimedia.

MULTIMEDIA: Animation & 3D Design		UNITS
Program Learning Outcomes –		
Upon completion, students will be able to:		
• Apply the elements and principles of design with competent skill and technique with computer based media;		
• Present an animation containing the elements of a fully developed narrative or experimental story;		
• Plan and produce a storyboard and three-part story structure utilizing the principles of sequential art that leads to a fully developed animation using the computer software.		
REQUIRED COURSES		UNITS
Multimd 310	Interactive Multimedia	3
Multimd 320	Web Design	3
Multimd 400	Introduction to Experimental Animation	3
Multimd 402	Animation Workshop	3
Multimd 430	Computer Applications for 3D Animation	3
Multimd 500	Multimedia Laboratory	1
		Total 16

MULTIMEDIA: Graphic & Web Design

Program Learning Outcomes –

Upon completion, students will be able to:

- Apply the elements and principles of design with competent skill and technique with computer based media;
- Demonstrate application of basic design principles with an emphasis on illustration, graphic layouts, logo creation, font creation, web navigation, web page layout and the ability to apply these principles to a specific aesthetic intent, including a functional knowledge of the traditions, conceptual modes, and evolutions of the discipline;
- Analyze visual forms and their aesthetic functions and basic design principles, with attention to such areas as design, color, and lighting.

REQUIRED COURSES		UNITS
Multimd 240	Graphic Design for Multimedia	3
Multimd 310	Interactive Multimedia	3
Multimd 320	Web Design	3
Multimd 340	Vector Graphics	3
Multimd 350	Advanced Web Design	3
Multimd 500	Multimedia Laboratory	1
		Total 16

MULTIMEDIA: Video Production

Program Learning Outcomes –

Upon completion, students will be able to:

- Apply the elements and principles of production design with competent skill and technique with production equipment such as cameras and computer editing software;
- Analyze historical, cultural, and aesthetic factors that led to rise of popular narrative and documentary filmmaking and how its model of production became the dominant form practiced by popular cinemas worldwide;
- Recognize, articulate, and judge the visual, verbal, and audio conventions through which images, words, and sounds make meaning in film and media texts.

REQUIRED COURSES		UNITS
Multimd 600	Story, Script & Screen	3
Multimd 610	Introduction to Digital Video Production	3
Multimd 620	Digital Audio	3
Multimd 630	Digital Video Production Footage Acquisition	3
Multimd 640	Digital Video Production Digital Editing	3
Multimd 500	Multimedia Laboratory	1
		Total 16

Disciplines • Educational Programs • Course Descriptions

100 INTRODUCTION TO MULTIMEDIA (CSU) 3 UNITS COMPUTER APPLICATIONS

Corequisite: MultiMd 500

Lecture 2 hrs, Lab 2 hrs

Students apply the principles of design to an electronic medium while developing the skills necessary to digitally manipulate graphic image and text with Adobe Photoshop. Students also learn the basics of Adobe Illustrator and integrate Photoshop materials with Illustrator documents.

110 VISUAL COMMUNICATION (CSU) 3 UNITS

Advisory: MultiMd 100 & 500

Lecture 2 hrs, Lab 2 hrs

A fundamental course on the nature of visual communication. Emphasis is placed on historical, philosophical, theoretical, cultural and practical aspects of art, design and media arts. Students integrate theory and applied technology to a variety of multimedia projects.

200 DIGITAL IMAGING (CSU) 3 UNITS

Advisory: MultiMd 100 | Lecture 2 hrs, Lab 2 hrs

Explore fundamentals of photography and camera operations: Photography's relationship with digital imaging, including lighting, composition, depth of field, lens flare, incident/reflective light, motion, color and presentation. Includes photographic demonstrations, portfolio and business strategies.

210 DIGITAL EDITING (CSU) 3 UNITS

Prerequisite: None | Lecture 2 hrs, Lab 2 hrs

Introduction to principles of motion graphics animation for multimedia. Students develop projects that integrate graphics, text and sound using non-linear post production tools.

220 ILLUSTRATION FOR MULTIMEDIA (CSU) 3 UNITS

Prerequisite: None | Lecture 2 hrs, Lab 2 hrs

Illustration techniques for commercial and graphic applications, such as logo design, character development, cover art and storyboards. The communication of original ideas through the use of various art media is emphasized.

240 GRAPHIC DESIGN FOR MULTIMEDIA (CSU) 3 UNITS

Advisory: MultiMd 100 | Lecture 2 hrs, Lab 2 hrs

Graphic Design for Multimedia focuses on page layout, typography and image text relationships. Students use digital layout software to create graphic design projects. An overview of the theory and history of graphic design is presented and integrated into projects.

300 DESIGN FOR 3-DIMENSIONAL (CSU) 3 UNITS COMPUTER APPLICATIONS

Corequisite: MultiMd 500 | Advisory: MultiMd 100

Lecture 2 hrs, Lab 2 hrs

Introduction to the basics of 3D modeling and animation. Emphasis is on the development of 3D content while applying creative design principles to a 3D environment. Students will model, assemble and animate text or characters utilizing 3D software.

310 INTERACTIVE MULTIMEDIA (CSU) 3 UNITS FOR EDUCATION & BUSINESS

Corequisite: MultiMd 500 | Advisory: MultiMd 100

Lecture 2 hrs, Lab 2 hrs

Students will create interactive environments and web animations. Introduces computer applications that integrate motion, sound and interactivity in multimedia projects. Emphasis is on innovative ways by which to conceptualize, design, and create interactive/multimedia art.

320 WEB DESIGN (CSU) 3 UNITS

Advisory: MultiMd 100 and 500

Lecture 2 hrs, Lab 2 hrs

An introduction to web page design and site management. The characteristics of web page design and navigation structures are analyzed. Emphasis is on innovative ways by which to conceptualize, design and create interactive websites.

340 VECTOR GRAPHICS (CSU) 3 UNITS

Advisory: MultiMd 100 and 500

Lecture 2 hrs, Lab 2 hrs

Use of vector graphics based software to produce illustrations for commercial applications. Emphasis is placed on the fundamental principles such as color, use of layers and typographic skill. Step-by-step demonstrations will lead into more creative projects.

350 WEB DESIGN II (CSU) 3 UNITS

Prerequisite: MultiMd 320

Advisory: MultiMd 100 and 500

Lecture 2 hrs, Lab 2 hrs

Advanced development of aesthetic and conceptual skills related to design for Web Sites. Techniques are demonstrated to further student experience with design, Dreamweaver, HTML5 and CSS (Cascading Style Sheets). Focus is also placed on usability, accessibility and web standards.

400 INTRODUCTION TO EXPERIMENTAL ANIMATION (CSU) 3 UNITS

Advisory: MultiMd 100 & 500

Lecture 2 hrs, Lab 2 hrs

Introduces the student to the basic principles of experimental animation. Emphasis is placed on the techniques, tools, and resources required to create a wide range of animated projects, including hand-drawn, clay animation and cut-out. Students apply concepts of timing, weight, personality, balance and style.

402 ANIMATION WORKSHOP (CSU) 3 UNITS
Advisory: MultiMd 100 & 500
Lecture 2 hrs, Lab 2 hrs

An introduction to the principles, practices, philosophy, and discipline of design for animation. Topics include treatments, character and object design, storyboards and animatics for time-based media such as animation and video.

430 COMPUTER APPLICATIONS FOR 3D ANIMATION (CSU) 3 UNITS
Advisory: MultiMd 100 & 500
Lecture 2 hrs, Lab 2 hrs

3D Animation and Design includes topics such as modeling using polygons and NURBS surfaces. Students learn how to create basic texture mapping, lighting, rendering, rig 3D models and how to animate them using kinematics and path animation. Students learn industry standard software for creating sophisticated 3D animations and environments.

440 GAME DESIGN (CSU) 3 UNITS
Prerequisite: None | Lecture 2 hrs, Lab 2 hrs
This is an introductory course in current techniques for electronic game design. Topics include creating graphic interfaces for games, the depiction of motion and the development of graphic components for games.

500 MULTIMEDIA LABORATORY (CSU) 1 UNIT
Prerequisite: None | Lab 2 hrs
This course is designed to reinforce lectures presented in multimedia classes. Emphasis is placed in applying design principles to projects using selected computer applications.

600 STORY, SCRIPT & SCREEN (CSU) 3 UNITS
Prerequisite: None | Lecture 3 hrs
Story, Script and Screen is a fundamental course on creative writing and scripting basics. The course structure includes lectures; short and feature film screenings; writing assignments; in-class group discussion and critique.

610 INTRODUCTION TO DIGITAL VIDEO PRODUCTION (CSU) 3 UNITS
Advisory: MultiMd 100 and 500
Lecture 2 hrs, Lab 2 hrs

An introductory course emphasizing the technical and creative aspects of digital video production and editing. Professional techniques in production and post-production are stressed.

620 DIGITAL AUDIO (CSU) 3 UNITS
Advisory: MultiMd 500
Lecture 2 hrs, Lab 2 hrs

An introductory course in digital audio where students work with current digital audio equipment to capture, mix and compose audio. This course lays the groundwork for understanding the professional world of sound production and will focus in three key areas: theory of sound, use of Digidesign Pro Tools for music production and film/TV post-production sound.

630 DIGITAL VIDEO PRODUCTION: FOOTAGE ACQUISITION (CSU) 3 UNITS
Advisory: MultiMd 500 and 610
Lecture 2 hrs, Lab 2 hrs

A fundamental course on developing professional quality video images using HD cameras and small lighting kits, with an emphasis on shooting for flexible editing and compositing. The course structure will include: lectures, camera demos, lighting, microphone techniques, as well as in-class group productions and critiques.

640 DIGITAL VIDEO PRODUCTION: DIGITAL EDITING (CSU) 3 UNITS
Advisory: MultiMd 500, 610 and 630
Lecture 2 hrs, Lab 2 hrs

An advanced course that focuses on post-production projects in video editing, compositing and motion graphics. Students will be exposed to the concepts and techniques of non-linear editing, computer generated imagery and live action video, special effects, and design of titling and motion graphics.

800 CURRENT TOPICS IN APPLIED MULTIMEDIA (CSU) 3 UNITS
Prerequisite: None | Lecture 2 hrs, Lab 2 hrs

This course introduces the student to current trends in applied multimedia. Topics include new technologies, current research, troubleshooting and future directions in multimedia applications.

MUSIC ARTS, MEDIA & PERFORMANCE

FACULTY: Deborah Paulsen, Chair

101 FUNDAMENTALS OF MUSIC (UC:CSU) 3 UNITS
Prerequisite: None | Lecture 3 hrs

Students will learn the basic rudiments of musical notation, scales, keys, intervals, rhythms, and basic harmonization through written work, ear-training and sight reading.

111 MUSIC APPRECIATION I (UC:CSU) 3 UNITS
Prerequisite: None | Lecture 3 hrs

A general introduction to music designed to enhance listening enjoyment and ability. It emphasizes the elements of music, the characteristic styles of major historical periods, and the lives and works of key composers within the Western musical tradition.

141 JAZZ APPRECIATION (UC: CSU) 3 UNITS
Advisory: English 28 or ESL 8 | Lecture 3 hrs

A survey of twentieth-century jazz including ragtime, blues, New Orleans and Chicago jazz, stride piano, swing, bebop, cool jazz, hard bop, modal jazz, third stream, avant-garde and free jazz, fusion, and experimental jazz styles.

321 ELEMENTARY PIANO I (UC:CSU) 2 UNITS
Prerequisite: None | Lecture 1 hr, Lab 2 hrs

Covers keyboard geography and functional keyboard skills in each key using popular tunes and classics arranged for the elementary pianist.

Disciplines • Educational Programs • Course Descriptions

322 ELEMENTARY PIANO II (UC:CSU) 2 UNITS

Prerequisite: Music 321 | Lecture 1 hr, Lab 2 hrs

Provides continuing instruction in basic piano skills, emphasizing all major and selected minor scales, primary chord progressions, triads, transposition, harmonization, repertoire and memorization.

323 ELEMENTARY PIANO III (UC:CSU) 2 UNITS

Prerequisite: Music 322 | Lecture 1 hr, Lab 2 hrs

Continued instruction in developing and refining piano skills with emphasis on major and minor scale techniques, chord progressions, triads, arpeggios, harmonization, transposition, repertoire from the major historical periods and memorization.

324 ELEMENTARY PIANO IV (UC:CSU) 2 UNITS

Continues instruction in developing and refining

piano skills with emphasis on piano technique, harmonization, transposition, stylistic consideration, and more advanced repertoire from the major historical periods. Open score reading and ensemble skills may also be introduced.

341 INTERMEDIATE PIANO (UC:CSU) 2 UNITS

Prerequisite: Music 324 | Lecture 1 hr, Lab 2 hrs

Covers piano technique, stylistic consideration and interpretation, which are further explored through the study and performance of piano literature from the four stylistic periods: Baroque, Classical, Romantic, and 20th century. Exercises for further technical development are also studied. Students may only enroll with instructor permission and must have completed Music IV Elementary Piano IV or its equivalent.

411 ELEMENTARY VOICE I (UC:CSU) 2 UNITS

Prerequisite: None | Lecture 1 hr, Lab 2 hrs

An introduction to vocal technique and aesthetic interpretation/expression, including posture and alignment, breath management, phonation, resonance, and articulation.

501 COLLEGE CHOIR (UC:CSU) 1 UNIT

Prerequisite: None | Lab 3 hrs

Introduction to choral ensemble singing. Emphasis is on vocal technique and choral elements, such as blend, intonation, diction and music reading. Repertoire is chosen on the basis of the ensemble's ability and represents historical and current styles of music.

NURSING LIFE SCIENCES

FACULTY: J. Michael Reynolds, Chair
Par Mohammadian, Vice-Chair

Certificate of Accomplishment in Certified Nursing Assistant and Home Health Aide

This certificate prepares students for a career in an area with a high demand for employment. Students will learn to become nursing assistants in long-term care facilities, acute-care settings, and home-care settings. Emphasis is given to safety principles, infection control, methods for providing physical care and emotional and social support. Also included are: medical legal issues, patient cultural differences, anatomy and physiology, pathophysiology, digital literacy, and resume/interview preparation, including practice interviews through LA Chamber of Commerce. The California Department of Health Services and the Red Cross certify the Certified Nursing and Home Health Aide programs of study.

Program Learning Outcomes –

Upon completion, students will be able to:

- Be eligible to take the State of California Certification Examination.
- Analyze and apply the fundamental nursing skills as required by the State of California Nurse Assistant Certification Examination.

REQUIRED COURSES

		UNITS
Hlth Occ 62	Skill Set for the Healthcare Professional	2
Hlth Occ 63	Basic Medical Terminology, Pathophysiology, and Pharmacology	2
Hlth Occ 64	Cultural and Legal Topics for Healthcare Professionals	1
Hlth Occ 65	Fundamentals for the Healthcare Professional	2.5
Nursing 399A	Certified Nursing Assistant	5
Nursing 399B	Home Health Aide	2
Nursing 56	Essential Practical Skills for Nurse Assistants	1
Ald Hth 21	Basic Life Support for the Healthcare Provider	0.5

Total 16

56 ESSENTIAL PRACTICAL (NDA) 1 UNIT RPT 3 SKILLS FOR NURSE ASSISTANT

Corequisite: Nursing 399A | Lecture 1 hr

Focuses on reinforcing and integrating the Certified Nurse Assistant duties and skills required to assist patients in long term care facilities with activities of daily living.

399A NURSE ASSISTANT TRAINING PROGRAM 5 UNITS

Prerequisite: English 21 or ESL 6A and

Math 105 | Lecture 3 hrs, Lab 6 hrs

Will provide students with an introduction to the health care field, working with residents/patients in the long-term care facility and the acute care setting. Emphasis will be given to safety principles, infection control, methods for providing physical care, and emotional and social support. Upon successful completion of this course students will be eligible to take the California's Nurse Assistant Certification Examination.

**399B HOME HEALTH AIDE
TRAINING PROGRAM**

2 UNITS

Prerequisite: Nursing 399A

Lecture 1 hr, Lab 2 hrs

Introduces students to the health care field, working with residents/patients in long-term care facilities, the acute care setting and the home care setting. Emphasis will be given to safety principles, infection control, methods for providing physical care, and emotional and social support. Upon successful completion of this course, the student is eligible to apply for certification as a Home Health Aide in the state of California.

OCEANOGRAPHY
PHYSICAL SCIENCES

FACULTY: Said Pazirandeh, Chair

**1 INTRODUCTION TO
OCEANOGRAPHY** (UC:CSU) 3 UNITS

Prerequisite: None | Lecture 3 hrs

An introduction to Oceanography. Topics include the formation of the evolution of the sea floor, islands, coastlines, properties of seawater, motions of the sea (waves, tides and currents) and marine life. Specific reference is made to the Southern California coast.

Personal Development
See COUNSELING

PHARMACY TECHNICIAN

FACULTY: J. Michael Reynolds, Chair
Par Mohammadian, Vice- Chair

**21 RETAIL PRODUCTS FOR
PHARMACY CLERKS** 3 UNITS

Advisories: English 28 or ESL 8 | Lecture 3 hrs
Designed for the Pharmacy Clerk student to provide basic knowledge about Over-the-Counter (OTC) products in relation to their accepted therapeutic uses. Students will understand the steps involved in safely choosing a non-prescription product.

23 INTRODUCTION TO PHARMACY 2 UNITS

Advisories: English 28 or ESL 8 | Lecture 2 hours
Examines the roles and opportunities open to pharmacy clerks and technicians in various practice settings. Students will be introduced to pharmaceutical dosage forms, the drug development process, and drug classification systems. This course also includes an introduction to prescription labeling and to the law and ethics for pharmacy practice.

29 BODY SYSTEMS I 3 UNITS

Advisories: English 28 or ESL 8 | Lecture 3 hours
Students will learn the indications, dosage, and adverse effects of prescription medications, nonprescription medications, and alternative therapies used to treat diseases affecting the muscular, skeletal, respiratory, renal, cardiovascular, and hematologic systems. Students will master an understanding of basic anatomy, physiology, pharmacology, and learn the brand and generic name, standard pronunciation, and routes of administration for each medication studied. Students will also learn medical terminology and abbreviations associated with the use of medication therapy affecting the body systems studied.



30 BODY SYSTEMS II 3 UNITS

Advisories: English 28 or ESL 8 | Lecture 3 hours
Students will learn the indications, dosage, and adverse effects of prescription medications, nonprescription medications, and alternative therapies used to treat diseases affecting the nervous, endocrine, gastrointestinal, reproductive, immune, ears/nose/throat, and dermatologic systems. Students will master an understanding of basic anatomy, physiology, pharmacology, and learn the brand and generic name, standard pronunciation, and routes of administration for each medication studied. Students will also learn medical terminology and abbreviations associated with the use of medication therapy affecting the body systems studied.

31 PHARMACY CALCULATIONS 2 UNITS

Advisory: Math 112 | Lecture 2 hours
Students will learn calculations related to drug dosage, measurements of strength, and preparation of medications. This course also includes inter-conversion of units in the metric and common systems of measurement. Emphasis is placed on unit-cancellation for solving pharmacy problems. This course includes a strong verbal component.

Disciplines • Educational Programs • Course Descriptions

PHILOSOPHY SOCIAL SCIENCES

FACULTY: Mark Pursley, Chair

Associate in Arts for Transfer (AA-T) Philosophy

Philosophy investigates concepts such as: knowledge, reason, truth, mind, freedom, argument, identity, religion, goodness, and justice. The study of philosophy cultivates the virtues of open-mindedness, tolerance of diverse perspectives, and critical thinking. Students interested in transferring and/or completing an Associate in Arts in Philosophy for Transfer should meet with a counselor to determine the coursework necessary to complete the requirements for general education and for the major. The Associate in Arts in Philosophy for Transfer Degree is intended for students who plan to complete a bachelor's degree in Philosophy or a similar major at a CSU campus. Students completing this degree are guaranteed admission to the CSU system, but not to a particular campus or major. This degree will provide the student with a strong foundation in the discipline, as well as breadth of exposure to various areas included in this field.

Program Learning Outcomes -

Upon completion, students will be able to:

- Demonstrate critical thinking skills necessary to assess real world issues from various perspectives;
- Complete a specified course level of preparation by completing requirements for an AA degree in Philosophy or transfer to a university;
- Demonstrate effective communication skills by reading primary and secondary source material, discussing course content, and writing one or more papers.

REQUIRED CORE

Philos 1 Introduction to Philosophy I

Philos 6 Logic in Practice
or Philos 9 Symbolic Logic I

LIST A: Select one (1) course:

Philos 14 History of Modern European Philosophy
or Any **Required Core** course not already used

LIST B: Select two (2) courses:

History 1 Introduction to Western Civilization I
History 2 Introduction to Western Civilization II
Philos 6 Logic in Practice (if not taken as part of Required Core)
or Any **LIST A** course not already used

LIST C: Select one (1) course:

Philos 20 Ethics
Philos 33 Comparative Survey of World Religions
or Any **LIST A** or **LIST B** course not already used

UNITS

6

3

3

3

6

3

Total 18

NOTE: A minimum of 60 units and a cumulative GPA of 2.0 or higher must be completed to earn the Associate in Arts for Transfer. Always consult a counselor for information on graduation requirements, residency requirements and transfer information.

1 INTRODUCTION TO PHILOSOPHY (UC:CSU) 3 UNITS

Prerequisite: None | Lecture 3 hrs

A survey of the fundamental questions about self, society, and the universe. Primary focus is on issues in metaphysics, theories of knowledge, moral theory, and philosophy of religion.

5 CRITICAL THINKING & COMPOSITION (UC:CSU) 3 UNITS

Prerequisite: English 101 | Lecture 3 hrs

Focuses on critical thinking so students will develop necessary skills for evaluating and constructing argumentative essays, and practice in applying these skills. Deduction, induction, and logical fallacies are also addressed.

6 LOGIC IN PRACTICE (UC:CSU) 3 UNITS

Prerequisite: None | Lecture 3 hrs

Introduces formal and informal methods for evaluating arguments. Students will learn to classify arguments as inductive or deductive, determine whether deductive arguments are valid or invalid, and identify strong and weak inductive arguments. Applications of critical thinking to social and political discourses will be considered.

9 SYMBOLIC LOGIC I (CSU) 3 UNITS

Prerequisite: None | Lecture 3 hrs

An introduction to the basic concepts of symbolic logic. This introduction will include the Origin and Use of Formal and Symbolic Logic, Truth Functional Connectives and Validity, Truth Tables, and Formal Deductive Proofs.

14 HISTORY OF MODERN EUROPEAN PHILOSOPHY (UC:CSU) 3 UNITS

Prerequisite: None | Lecture 3 hrs

An introduction and survey of modern European Philosophy, beginning with the inception of Modern Science with Copernicus and Galileo, the inception of modern philosophy proper with Rene Descartes, through the Rationalists and Empiricists, German Idealism, Positivism, Marxism, Linguistic and Analytic Philosophy, Phenomenology, Philosophy of Science, Existentialism, Feminism, Deconstruction, and other recent trends.

20 ETHICS (UC:CSU) 3 UNITS

Prerequisite: None | Lecture 3 hrs

Surveys the language of moral discourse (metaethics), different ways of deciding right and wrong (ethical theories), and the effort to reach acceptable judgments on both individual and social moral issues (practical ethics).

33 COMPARATIVE SURVEY OF WORLD RELIGIONS (UC:CSU) 3 UNITS

Prerequisite: None | Lecture 3 hrs

An historical overview of the principal religious traditions of the world, concentrating on Hinduism and Buddhism, Confucianism and Daoism, Judaism, Christianity, and Islam. Considers origins, principal beliefs and practices, and contemporary issues.

PHOTOGRAPHY

ARTS, MEDIA & PERFORMANCE

FACULTY: Deborah Paulsen, Chair
Curtis Stage, Vice Chair

9 INTRODUCTION TO CAMERAS & COMPOSITION (CSU) 3 UNITS

Prerequisite: None | Lecture 3 hrs

Course covers basic information in the use of cameras, lenses, film and exposure to produce good photographs.

10 BEGINNING PHOTOGRAPHY (UC:CSU) 3 UNITS

Advisory: MultiMd 100 & 500

Lecture 2 hrs, Lab 3 hrs

Supplies: Students are encouraged to provide a Digital SLR camera and must have storage media.

Covers camera operation, exposure, scanning techniques, composition and aesthetics. The student will learn how to photograph, transfer images to a computer; edit the images using industry standard software and create their own prints. Emphasis is placed on communicating both fine art and commercial photography techniques.

11 ADVANCED PHOTOGRAPHY (UC:CSU) 4 UNITS

Prerequisite: Photo 10 or permission of instructor | Lecture 2 hrs, Lab 6 hrs

Provides theory and practice of contemporary use of the camera; training in projection control; includes 4x5 use, zone system, digital photography and special effects procedures with an emphasis on creative thinking and idea preparation and execution.

12 ADVANCED PHOTOGRAPHIC TECHNIQUES (CSU) 4 UNITS

Prerequisite: Photo 11 or permission of instructor | Lecture 2 hrs, Lab 6 hrs

Offers a study of advanced photographic techniques theory, chemicals and formulas necessary to the creative photographer. Includes special effects, such as solarization, texture screens, controls of lighting, infrared photography, digital photography, etc.

47 INTRO TO COMPUTERIZED DIGITAL PHOTOGRAPHY (CSU) 3 UNITS

Prerequisite: None | Lecture 2 hrs, Lab 3 hrs

This course is an introduction to digital image processing. Adobe Photoshop software will be used. Topics will include tools selection, processes, channels, layers, filters, sharpening, unsharp mask, despeckle, modes, filters, type effects, levels, curves, ethics.

Physical Education

See KINESIOLOGY

PHYSICAL SCIENCE

PHYSICAL SCIENCES

FACULTY: Said Pazirandeh, Chair
Richard Rains, Vice Chair

EDUCATIONAL PROGRAM

This curriculum is designed to provide an opportunity for the student to complete an undergraduate major in Physical Science.

NOTE: A minimum of 60 units and a cumulative GPA of 2.0 or higher must be completed to earn the Associate in Arts Degree. Always consult a counselor for information on graduation requirements, residency requirements and transfer information.

ASSOCIATE IN ARTS - Physical Science

For General Education Requirements, see page 73

Program Learning Outcomes –

Upon completion, students will be able to:

- Describe and analyze naturally occurring, repeatable physical events and interactions and identify their physical origin;
- Deduce cause and effect relationships between these interactions through progressive scientific modeling using a variety of mathematical techniques;
- Students will analyze and interpret data (from laboratory exercises, mathematical equations, or computer programs), and draw logical conclusions using the scientific method, inductive and deductive reasoning;
- Students will apply known scientific laws to predict outcomes of specific physical situations.

REQUIRED COURSES

		UNITS
Astron 1	Elementary Astronomy	3
Astron 5	Fundamentals of Astronomy Laboratory	1
Biology 3	Introduction to Biology	4
Chem 51 or Chem 65	Fundamentals of Chemistry I Introductory General Chemistry	4-5
Math 260 or Math 265 or Math 266 or Math 267	Pre Calculus Calculus with Analytic Geometry I Calculus with Analytic Geometry II Calculus with Analytic Geometry III	5
Physics 6	General Physics I	4
		Total 21-22

RECOMMENDED COURSES

Chem 101	General Chemistry I	5
Chem 102	General Chemistry II	5
EnvSci 2	The Human Environment: Biological Processes	3
Physics 7	General Physics II	4

Disciplines • Educational Programs • Course Descriptions

1 PHYSICAL SCIENCE I (UC:CSU) 3 UNITS
Prerequisite: None | Advisory: Math 115
Lecture 3 hrs

Course is designed for the non-science major, and provides an introduction to the fundamental principles of physics, chemistry, astronomy and geology. Elementary quantitative concepts are used to supplement the conceptual emphasis of this course.

14 PHYSICAL SCIENCE LABORATORY (UC:CSU) 1 UNIT
Corequisite: Physical Science I (lecture)
Lab 2 hrs

Laboratory experiments and a limited number of demonstrations will be performed that will allow students to visualize and apply basic concepts in physics and chemistry. Students will acquire basic problem-solving and laboratory skills.

PHYSICS PHYSICAL SCIENCES

FACULTY: Said Pazirandeh, Chair
Richard Rains, Vice Chair

6 GENERAL PHYSICS I (UC:CSU) 4 UNITS
Prerequisite: Math 123C or Math 125 and Math 240
Lecture 3 hrs, Lab 3 hrs

An introductory course in physics covering mechanics and solids, heat and sound. This course is designed for the health science majors (Environmental and Occupational Health, Physical Therapy, Radiologic Technology), Pre-medical, Pre-dental, Pre-optometry, Pre-pharmacy, and Geology majors.

7 GENERAL PHYSICS II (UC:CSU) 4 UNITS
Prerequisite: Physics 6 | Lecture 3 hrs, Lab 3 hrs

This course is a continuation of Physics 6, covering electricity and magnetism, light and modern physics. The course is designed for the health science majors (Environmental and occupational Health, Physical Therapy, Radiologic Technology), Pre-medical, Pre-dental, Pre-optometry, Pre-pharmacy, and Geology majors.

37 PHYSICS FOR ENGINEERS & SCIENTISTS I (UC:CSU) 5 UNITS
Prerequisite: Math 265
Lecture 4 hrs, Lab 3 hrs

Designed for Physics, Astronomy, Chemistry, Engineering & Mathematics majors. This is the first semester of a three semester calculus-level sequence in introductory college Physics. Topics include kinematics, dynamics, laws of motion, and conservation laws for particles and systems of particles in both translation and rotation.

38 PHYSICS FOR ENGINEERS & SCIENTISTS II (CSU) 5 UNITS
Prerequisite: Physics 37 and Math 266
Lecture 4 hrs, Lab 3 hrs

Designed for Physics, Astronomy, Chemistry, Engineering and Mathematics majors. Topics include mechanical waves, electric charge and electric fields, electric energy storage, electric currents, magnetism, electromagnetic induction, electromagnetic oscillations, AC circuits, and Maxwell's Equations.

39 PHYSICS FOR ENGINEERS & SCIENTISTS III (CSU) 5 UNITS

Prerequisite: Physics 37 and Math 266
Lecture 4 hrs, Lab 3 hrs

Designed for Physics, Astronomy, Chemistry and Engineering majors. Topics include thermodynamics, geometric optics, the wave nature of light, special relativity, early quantum theory, atomic and nuclear physics.

PHYSIOLOGY LIFE SCIENCES

FACULTY: J. Michael Reynolds, Chair
Dr. Par Mohammadian, Vice Chair

Program Learning Outcomes –

upon completion, students will be able to:

- Explain and describe a fundamental homeostatic process of the human body and how they are controlled by the endocrine and nervous systems.

1 INTRODUCTION TO HUMAN PHYSIOLOGY (UC:CSU) 4 UNITS
Prerequisite: Biology 3 or Biology 5, and Anatomy 1, and Chemistry 51 or Chemistry 65 or Chemistry 101, and English 28 or ESL 8
Lecture 3 hrs, Lab 3 hrs

Examines the function of the following human systems: integumentary, skeletal, muscular, nervous, circulatory, respiratory, digestive, urinary, endocrine, lymphatic, and reproductive. Labs include many hands-on and computer-assisted applications.

POLITICAL SCIENCE

SOCIAL SCIENCES

FACULTY: Mark Pursley, Chair
Dr. Ebru Durukan, Vice Chair

AMERICAN HISTORY INSTITUTIONS TRANSFER REQUIREMENT

If you took a U.S. history course outside of California, make certain you meet the California State and local government transfer requirements to the California State Universities as listed below. Please consult with a counselor or a history instructor.

U.S.-1 History – History 11, 12, AfroAm 4, Chicano 8, Econ 10

U.S.-2 Constitution – PolSci 1

U.S.-3 State and local government – PolSci 1

EDUCATIONAL PROGRAMS

This curriculum is designed to provide an opportunity for the students to complete an undergraduate major in Political Science.

Associate in Arts for Transfer (AA-T) Political Science

The Associate in Arts in Political Science for Transfer provides the student with a strong foundation in the discipline, as well as breadth of exposure to various areas included in this field. Political Science majors are given opportunities to develop a broad understanding of core political themes, concepts, and theories. Political Science provides an intellectual background for students considering careers in business, social services, public policy, government service, international non-governmental organizations, foundations, or academia. Students interested in transferring and/or completing an Associate in Arts in Political Science for Transfer should meet with a counselor to determine the coursework necessary to complete the requirements for general education and for the major.

Program Learning Outcomes –

Upon completion, students will be able to:

- Complete a variety of course offerings to graduate with an AA degree or transfer to universities;
- Demonstrate effective communication skills by reading primary and secondary source material, discussing course content, and writing one or more papers;
- Participate in and critically analyze the civic and political system.

REQUIRED CORE

PolSci 1	The Government of the United States	UNITS	
			3
LIST A: Select three (3) courses:			9-10
PolSci 2	Modern World Governments		
Pol Sci 3	Intro to Political Science		
PolSci 5	The History of Western Political Thought		
PolSci 7	Contemporary World Affairs		
Math 227	Statistics		

LIST B: Select two (2) courses:

History 11	Political & Social History of the US I	6
Soc1	Introduction to Sociology	
Psych 1	General Psychology I	
or Any LIST A course not already used		

Total 18-19

NOTE: A minimum of 60 units and a cumulative GPA of 2.0 or higher must be completed to earn the Associate in Arts for Transfer. Always consult a counselor for information on graduation requirements, residency requirements and transfer information.

1 THE GOVERNMENT OF THE UNITED STATES (UC:CSU) 3 UNITS

Prerequisite: None | Lecture 3 hrs
Principles, institutions, functions, and policy processes of the American Political System: including ideology and government; the constitution; federalism; Congress; the Presidency, the Judiciary; Civil Rights and Liberties; the media, elections and voting, political parties, interest groups. Also includes California government structure and constitution.

2 MODERN WORLD GOVERNMENTS (UC:CSU) 3 UNITS

Prerequisite: None | Lecture 3 hrs
A comparative study of the major governments of the modern world in terms of their ideologies, political institutions and processes, AND political cultures. Emphasis is placed on the governments of the United Kingdom, Germany, Mexico, Brazil, Russian Federation, China, India, Nigeria and Iran.

3 INTRO TO POLITICAL SCIENCE (CSU) 3 UNITS

Prerequisite: None | Lecture 3 hrs
Introduction to politics and political science: power, democracy and authoritarianism, political participation, the state, political institutions, subfields of the discipline, and political research methodology.

5 THE HISTORY OF WESTERN POLITICAL THOUGHT (UC:CSU) 3 UNITS

Prerequisite: None | Lecture 3 hrs
Provides overall perspective of major political movements of history from the rising of Egyptian, Greek and Roman Empires to fascism and communism as seen by great political thinkers from Plato, Aristotle, St. Augustine, Machiavelli, Marx and Lenin. Includes discussions on modern and contemporary theories.

7 CONTEMPORARY WORLD AFFAIRS (UC:CSU) 3 UNITS

Prerequisite: None | Lecture 3 hrs
Major themes and aspects of current international politics are introduced. Topics include but are not restricted to international relations theories, globalization, power, diplomacy, war and peace, terrorism, and economic development.

185 DIRECTED STUDY (CSU) 1 UNIT

Provides opportunity for in-depth study of a chosen area of Political Science on a contract basis, under the direction of a supervising instructor.

Disciplines • Educational Programs • Course Descriptions

285 DIRECTED STUDIES (CSU) 2 UNITS

Provides opportunity for in-depth study of a chosen area of Political Science on a contract basis, under the direction of a supervising instructor.

385 DIRECTED STUDIES (CSU) 3 UNITS

Conference: 1 hour per unit

Provides opportunity for in-depth study of a chosen area of Political Science on a contract basis, under the direction of a supervising instructor.

PORTUGUESE FOREIGN LANGUAGES

FACULTY: Dr. Jolie Scheib, Chair

1 ELEMENTARY PORTUGUESE I (UC: CSU) 5 UNITS

Prerequisite: None | Lecture 5 hrs

First course in understanding, speaking, reading and writing Portuguese. Introduction to the culture and civilization of Brazil. Intended primarily for students with little or no knowledge of Portuguese.

2 ELEMENTARY PORTUGUESE II (UC: CSU) 5 UNITS

Prerequisite: Portgse 1 | Lecture 5 hrs

Second course in understanding, speaking, reading and writing Portuguese. Continuation of study of the culture and civilization of Brazil. Intended primarily for students learning Portuguese as a foreign language.

PSYCHOLOGY SOCIAL SCIENCES

FACULTY: Mark Pursley, Chair
Dr. Christopher F. Williams, Vice Chair

EDUCATIONAL PROGRAM

This curriculum is designed to provide an opportunity for the student to complete an undergraduate major in Psychology or Psychological Services. The student is also urged to investigate related areas through elective courses.

NOTE: A minimum of 60 units and a cumulative GPA of 2.0 or higher must be completed to earn the Associate in Arts Degree. Always consult a counselor for information on graduation requirements, residency requirements and transfer information.

ASSOCIATE IN ARTS - Psychology

For General Education Requirements, see page 73

Program Learning Outcomes –

Upon completion, students will be able to:

- Complete a variety of course offerings to graduate with an AA degree or transfer to universities;
- Demonstrate psychological knowledge of current real world issues and the various perspectives on them;
- Compare and contrast at least two major psychological theories.

REQUIRED COURSES

Psych 1	General Psychology I	3
Psych 2	Biological Psychology	3
Biology 3 or Biology 6	Introduction to Biology / General Biology I	4-5
Math 227	Statistics	4
SELECT TWO (2) ADDITIONAL COURSES:		6
Psych 13 or Soc 24	Social Psychology	
Psych 14	Abnormal Psychology	
Psych 41	Life Span Psychology	
Psych 52	Psychological Aspects of Human Sexuality	
Soc 1	Introduction to Sociology	

Total 20-21

RECOMMENDED COURSES

ChDev 1	Child Growth & Development
Psych 32	Psychology of Women
Soc 2	American Social Problems
Soc 11	Ethnic & Racial Minorities in the U.S.

Associate in Arts for Transfer (AA-T) Psychology

The Associate in Arts in Psychology for Transfer prepares students to transfer into the CSU system. Students completing the Associate in Arts in Psychology for Transfer will receive a strong, basic foundation in core areas of the discipline. Students interested in transferring and/or completing an Associate in Arts in Psychology for Transfer degree should meet with a counselor to determine the coursework necessary to complete the requirements for general education and for the major.

Program Learning Outcomes –

Upon completion, students will be able to:

- Complete a variety of course offerings to graduate with an AA degree or transfer to universities;
- Demonstrate critical thinking skills necessary to assess real world issues and the various perspectives on them;
- Demonstrate effective communication skills by reading primary and secondary source material, discussing course content, and writing one or more papers;
- Apply the diverse assumptions and values that shape our experiences and or/attitudes of the world.

REQUIRED CORE

Psych 1	General Psychology I	3
Psych 74	Research Methods in the Behavioral Sciences	3
Math 227	Statistics	4



LIST A: Select one (1) course
 Psych 2 Biological Psychology
 Biology 3 Introduction to Biology
 or Biology 6 General Biology I

LIST B: Select one (1) course
 ChDev 1 Child Growth and Development
 Psych 41 Life Span Psychology
 or Any **LIST A** course not already used

LIST C: Select one (1) course
 Psych 13 Social Psychology
 Psych 14 Abnormal Psychology
 Psych 52 Psychological Aspects of Human Sexuality
 Psych 90 Introduction to Counseling
 English 102 Reading and Composition II
 or English 103 Composition and Critical Thinking
 Phil 6 Logic in Practice
 Soc 1 Introduction to Sociology
 or Any **LIST A** or **LIST B** course not already used

Total 19-21

1 GENERAL PSYCHOLOGY I (UC:CSU) 3 UNITS
 Advisory: English 28 or ESL 8 | Lecture 3 hrs
 Covers biological foundations of behavior, various theoretical perspectives including learning, sensation and perception, psychological disorders, health and stress, personality, and intelligence theories as well as experimental and research methodology.

2 BIOLOGICAL PSYCHOLOGY (UC:CSU) 3 UNITS
 Prerequisite: Psych 1 | Lecture 3 hrs
 Introduction to the scientific study of the biological, physiological, and neuroanatomical foundations of behavior and mental processes through discussion of research of fundamental concepts and issues in psychology. The structure and functions of the brain and the nervous system and their effects on human behavior are studied.

13 SOCIAL PSYCHOLOGY (UC:CSU) 3 UNITS
 Prerequisite: None | Lecture 3 hrs
 Examines how individuals are influenced by the behavior and presence of others. Emphasizes such topics as: liking and loving; forming impressions; aggression; changing attitudes; interactions within groups; and the psychology of conformity, obedience, and prejudice.

3-5 14 ABNORMAL PSYCHOLOGY (UC:CSU) 3 UNITS
 Prerequisite: Psych 1 | Lecture 3 hrs
 Examines the etiology, assessment and classification, diagnosis, and treatment of the major psychological/psychiatric disorders. Topics include the history of abnormal psychology, as well as anxiety, mood, personality, dissociative, somatoform, cognitive disorders, sexual dysfunctions, addiction, schizophrenia, and disorders of childhood and adolescence. This course will provide an introduction to the Diagnostic and Statistical Manual of Mental Disorders Text Revision (DSM-IV-TR) Fourth Edition.

3 41 LIFE SPAN PSYCHOLOGY (UC:CSU) 3 UNITS
 Prerequisite: Psych 1 | Advisory: Eng 28 or ESL 8
 Lecture 3 hrs
 Individual psychological development from conception to death, including physical, cognitive and psychosocial aspects. Major theories and research methodologies are introduced. Family, peer, education and social influences on intelligence, gender, personality and relationships are explored. Practical applications are emphasized. Special emphasis is given to social and cultural influences.

3 52 PSYCHOLOGICAL ASPECTS OF HUMAN SEXUALITY (UC:CSU) 3 UNITS
 Prerequisite: None | Lecture 3 hrs
 Explores the psychological aspects of human sexuality. Addresses areas of sexual development and functioning including but not limited to: self-awareness/awareness of sexual identity; sex organs and their functions; sexual myths and fallacies; sexual dysfunction and variant behavior.

74 RESEARCH METHODS IN THE BEHAVIORAL SCIENCES (CSU) 3 UNITS
 Prerequisite: Psych 1 & Math 227 | Lecture 3 hrs
 Students are introduced to basic research concepts, designs, and statistical techniques used in the behavioral and social sciences. Covers literature reviews, critical evaluations of articles in professional journals, the design of research studies, and use of computer-based statistical packages to analyze data ('Statistical Package for the Social Sciences-SPSS). Independent research focuses on the procedures involved in conducting studies and writing APA-style research reports.

90 INTRODUCTION TO COUNSELING (CSU) 3 UNITS
 Prerequisite: Psych 1 | Advisory: Eng 28 or ESL 8
 Lecture 3 hrs
 Examines the various counseling styles and techniques and the theoretical foundations. Students will develop skills in the understanding of developmental, nondirective, psychodynamic, transactional and other approaches to individual and group counseling. The characteristics of a workable counseling and guidance program and the techniques used to collect, record, interpret, and use guidance data will be examined. The nature, purpose, objectives, and approaches to counseling in health, welfare, social service and rehabilitation agencies will be discussed.

185 DIRECTED STUDY (CSU) 1 UNIT
 Allows students to pursue directed study in Psychology on a contract basis under the direction of a supervising instructor.

285 DIRECTED STUDY (CSU) 2 UNITS
 Allows students to pursue directed study in Psychology on a contract basis under the direction of a supervising instructor.

385 DIRECTED STUDY (CSU) 3 UNITS

Disciplines • Educational Programs • Course Descriptions

Allows students to pursue directed study in Psychology on a contract basis under the direction of a supervising instructor.

SOCIOLOGY SOCIAL SCIENCES

FACULTY: Mark Pursley, Chair | Jill Biondo

EDUCATIONAL PROGRAM

This curriculum is designed to provide an opportunity for the student to complete an undergraduate major in Sociology by exploring topics such as Social Problems, Crime, Race Relations, Research, Gender, Family, and Social Psychology.

Associate in Arts for Transfer (AA-T) Sociology

The Associate in Arts in Sociology for Transfer provides the student with a strong foundation in the discipline, as well as breadth of exposure to various areas included in this field. Sociology majors are given opportunities to develop a broad understanding of core sociological theories and the methodological skills used to evaluate human behavior and social organizations. Sociology provides an intellectual background for students considering careers in business, social services, public policy, government service, international non-governmental organizations, foundations, or academia. Students interested in transferring and/or completing an Associate in Arts in Sociology for Transfer should meet with a counselor to determine the coursework necessary to complete the requirements for general education and for the major.

Program Learning Outcomes -

Upon completion, students will be able to:

- Evaluate the merits of sociological research methods (e.g., interviews, case studies, field work, content analysis, and survey design); select and apply these methods to formulate and investigate well-reasoned sociological research questions.
- Compare and assess the features of the major sociological theories and perspectives of human behavior and social situations.
- Demonstrate the ability to be academically successful in at least two separate areas of sociological emphasis (Marriage and Family, Race and Ethnic Relations, Crime and Delinquency, Social Psychology, Social Problems, and/or Gender).

REQUIRED CORE

Soc 1	Introduction to Sociology	UNITS	3
Select two (2) courses			6-7
Soc 2	American Social Problems		
Soc 4	Sociological Analysis		
Math 227	Statistics		
LIST A: Select two (2) courses			6
Soc 3	Crime & Delinquency		
Soc 11	Ethnic & Racial Minorities in the U.S.		
Soc 24			
or Psych 13	Social Psychology		
Soc 28	The Family: A Sociological Approach		
LIST B: Select one (1) course			3
Adm Jus 1	Introduction to Administration of Justice		
Anthro 102	Human Ways of Life: Cultural Anthropology		
Geog 2	Cultural Elements of Geography		
Philos 6	Logic in Practice		
or Any LIST A course not already used			
			Total 18-19

NOTE: A minimum of 60 units and a cumulative G.P.A. of 2.0 or higher must be completed to earn the Associate in Arts for Transfer. Always consult a counselor for information on graduation requirements, residency requirements and transfer information.

1 INTRODUCTION (UC:CSU) 3 UNITS

TO SOCIOLOGY

Prerequisite: None | Lecture 3 hrs

Presents an orientation to the field of sociology, including core sociological theories in the areas of socialization; the impact of social institutions such as the family, culture, religion, education, government; concepts of conformity and deviance; and the study of social inequalities in U.S. society due to race/ethnicity, sex, gender and age.

2 AMERICAN SOCIAL PROBLEMS (UC:CSU) 3 UNITS

Prerequisite: None | Lecture 3 hrs

Sociological concepts and theories that explain a range of social problems in the US including: crime, drugs, immigration, poverty, racism, issues of social privilege, health care, the environment, educational inequalities, terrorism; and the potential solutions to these social problems.

3 CRIME & DELINQUENCY (UC:CSU) 3 UNITS

Prerequisite: None | Lecture 3 hrs

Examines the nature and extent of crime and delinquency, theories of causation, types of juvenile and adult offenses, and efforts by society to cope with law violations: includes programs for prevention, correction, and rehabilitation.

4 SOCIOLOGICAL ANALYSIS (UC:CSU) 3 UNITS

Prerequisite: Soc 1 | Lecture 3 hrs

An introduction to the scientific study of social research: topics include research design, conceptualization, measurement, sampling methodology, qualitative and quantitative data analysis. Students will analyze specific data collected in the field.

11 ETHNIC & RACIAL MINORITIES IN THE UNITED STATES (UC:CSU) 3 UNITS

Prerequisite: None | Lecture 3 hrs

Describes how race, class, religion and gender shape the experience of diverse groups in America: patterns of prejudice and discrimination that affect major ethnic, racial and minority groups; and the complexities of race relations and its impact on society.

24 SOCIAL PSYCHOLOGY (UC:CSU) 3 UNITS

Prerequisite: None | Lecture 3 hrs
Examines how individuals are influenced by the behavior and presence of others. Emphasized such topics as: liking and loving; forming impressions; aggression; changing attitudes; interactions within groups; and the psychology of conformity, obedience, and prejudice.

28 THE FAMILY: A SOCIOLOGICAL APPROACH (UC:CSU) 3 UNITS

Prerequisite: None | Lecture 3 hrs
Examines the diverse definitions of the family; analysis of family as an institution, including historical changes in the role of marriage, divorce, cohabitation, parenting, work, communication, aging, and family violence. The impact of culture, race, social class, gender, and sexual orientation onto individuals and society, according to sociological research.

31 SOCIOLOGY OF GENDER (CSU) 3 UNITS

Prerequisite: None | Lecture 3 hrs
This course examines the social significance of gender in contemporary U.S. society. It analyzes the social construction of gender ideology and how women and men's experiences are affected by social institutions such as work, education, the family, and the criminal justice system. Men and women's differential experiences are analyzed within the context of race, class, and sexual orientation. The course demonstrates how the experiences of men and women are created through social institutions and can, therefore, be transformed through social and institutional change.

185 DIRECTED STUDY (CSU) 1 UNIT

Provides opportunity for in-depth study of a chosen area of Sociology on a contract basis, under the direction of a supervising instructor.

285 DIRECTED STUDIES (CSU) 2 UNITS

Provides opportunity for in-depth study of a chosen area of Sociology on a contract basis, under the direction of a supervising instructor.

385 DIRECTED STUDY (CSU) 3 UNITS

Provides opportunity for in-depth study of a chosen area of Sociology on a contract basis, under the direction of a supervising instructor.

SPANISH

FOREIGN LANGUAGES

FACULTY: Dr. Jolie Scheib, Chair

EDUCATIONAL PROGRAM

This curriculum is designed to prepare native and near native speakers of Spanish as well as those students studying Spanish as a foreign language to complete a Bachelor's Degree in Spanish. Students will have the opportunity to develop proficiency in understanding, speaking, reading and writing Spanish and to acquaint themselves with Hispanic cultures and civilization.

NOTE: A minimum of 60 units and a cumulative GPA of 2.0 or higher must be completed to earn the Associate in Arts Degree. Always consult a counselor for information on graduation requirements, residency requirements and transfer information.

ASSOCIATE IN ARTS - Spanish

For General Education Requirements, see page 73

Program Learning Outcomes –

Upon completion, students will be able to:

- Communicate orally and in writing in Spanish with fluency and comprehension (Written and Oral Communication);
- Using the Spanish language describing people, situations, relationships and places (Written and Oral Communication);
- Read critically with ability to summarize and analyze main ideas (Written and Oral Communication).

REQUIRED COURSES

Linguistics 1	Introduction to Language & Linguistics	3
and three (3) courses from the following:		
(to include Spanish 4)		15
Spanish 1	Elementary Spanish I	
Spanish 2	Elementary Spanish II	
Spanish 3	Intermediate Spanish I	
Spanish 4	Intermediate Spanish II	
Spanish 5	Advanced Spanish I	
Spanish 6	Advanced Spanish II	
		Total 18

NOTE: Native or near-native speakers of Spanish normally begin with Spanish 3, followed by Spanish 4, 5, and 6 in that order.

Associate in Arts for Transfer (AA-T) Spanish

The Associate in Arts in Spanish for Transfer prepares students to transfer into the CSU system. Students completing the Associate in Arts in Spanish for Transfer are introduced to the language, history, culture and literature of the Spanish-speaking world through coursework and language laboratory assignments. Students acquire basic skills through listening, speaking, reading, writing, and cultural components of the curriculum to carry on a basic conversation. Students will be prepared for transfer into a baccalaureate degree program in Spanish or a similar major at a CSU.

Program Learning Outcomes –

Upon completion, students will be able to:

- Produce sentences in all tenses and modes;
- Communicate orally and in writing in Spanish with fluency and comprehension;
- Compare and contrast Spanish and Latin American Cultures with their own culture;
- Express personal feelings while describing people, situations, relationships and places;
- Read critically with ability to summarize and analyze main ideas.

REQUIRED CORE

Spanish 1	Elementary Spanish I	5
Spanish 2	Elementary Spanish II	5
Spanish 3	Intermediate Spanish I	5
Spanish 4	Intermediate Spanish II	5
LIST A: Select one (1) course:		3-5
Spanish 5	Advanced Spanish I	
Spanish 6	Advanced Spanish II	
Chicano 37	Chicano Literature	
Chicano 44	Mexican Civilization	
		Total 23-25

NOTE: A minimum of 60 units and a cumulative GPA of 2.0 or higher must be completed to earn the Associate in Arts for Transfer. Always consult a counselor for information on graduation requirements, residency requirements and transfer information.

Disciplines • Educational Programs • Course Descriptions

1 **ELEMENTARY SPANISH I** (UC:CSU) 5 UNITS

Prerequisite: None | Lecture 5 hrs

Course explores basic grammar and communication through listening, reading, speaking, and writing. It emphasizes clear pronunciation, vocabulary building, the study of grammatical patterns and expressions, and idiomatic usages that prepare students to function within the contexts relevant to everyday life. Culture and geography are also integrated through readings, and supported and enhanced by multimedia.

2 **ELEMENTARY SPANISH II** (UC:CSU) 5 UNITS

Prerequisite: Spanish 1 | Lecture 5 hrs

Continues the introduction of the fundamentals of Spanish grammar, emphasizing communication of basic topics such as travel, housing, the extended family, health, shopping, and technology. The course stresses oral and written communication in the past, present, and future tenses and introduces basic compound tenses. Further studies on the cultural heritage of Latin America and Spain enrich students' understanding of the language.

3 **INTERMEDIATE SPANISH I** (UC:CSU) 5 UNITS

Prerequisite: Spanish 2 or equivalent

Lecture 5 hrs

A more intensive study of the language, including idiomatic expressions and irregular structures. Stress on fluency in oral expression and facility in writing. Comprehensive review of grammar and study of advanced grammatical concepts. Extensive reading and discussion in Spanish of literary and cultural texts. Discussion, in Spanish, of Spanish and Spanish-American life and difficulties.

4 **INTERMEDIATE SPANISH II** (UC:CSU) 5 UNITS

Prerequisite: Spanish 3 or equivalent

Lecture 5 hrs

Further development of writing and communication skills through the study of representative Spanish and Latin American literary and cultural works; focus is on analysis and discussion. Sustained study of grammar and vocabulary with emphasis on complex structures, stylistics, and use of idiomatic expressions. Basic computer skills required for accessing online activities.

5 **ADVANCED SPANISH I** (UC:CSU) 5 UNITS

Prerequisite: Spanish 4 or equivalent

Lecture 5 hrs

Introduction to the major literary movements in Spain and Latin American literature through the study of representative literary and cultural texts of different genres. Emphasis on improving oral expression, comprehension, reading and textual analysis, and composition. Stresses oral and written reports within the context of Latin American literature and civilization. Basic computer skills required for accessing and performing online activities.

6 **ADVANCED SPANISH II** (UC:CSU) 5 UNITS

Prerequisite: Spanish 5 or equivalent

Lecture 5 hrs

Study of the major Latin America/Spain literary movements in Spanish literature through the study of representative literary and cultural texts of different genres. Emphasis on improving oral expression, comprehension, reading and textual analysis, and composition. Stresses oral and written reports within the context of the literature and civilization of Spain. Basic computer skills required for accessing and performing online activities.

8 **CONVERSATIONAL SPANISH** (CSU) 2 UNITS

Prerequisite: Spanish 2 or equivalent

Lecture 2 hrs

Practical conversation and improvement of conversational fluidity based on everyday experiences, current events, cinema, cultural topics and readings. Emphasis on use of idiomatic expressions and current usages. Training in pronunciation, enunciation, and vocabulary-building. Basic computers required for accessing online information. Not open to native speakers of Spanish.

185 **DIRECTED STUDY** (CSU) 1 UNIT

Provides opportunity for in-depth study of a chosen area of Spanish on a contract basis, under the direction of a supervising instructor.

Speech

See COMMUNICATION STUDIES

TECHNICAL STAGE PRODUCTION *ARTS, MEDIA & PERFORMANCE*

FACULTY: Deborah Paulsen, Chair | Robert Cucuzza

342 **TECHNICAL STAGE PRODUCTION** (UC:CSU) 2 UNITS 3 RPT

Prerequisite: None | Lecture 1 hr, Lab 3 hrs

Students will gain practical experience in the application of production responsibilities in any of the following: stage management, house management, construction, scenery, properties, costume, lighting, sound, and running crews.

THEATER

ARTS, MEDIA & PERFORMANCE

FACULTY: Deborah Paulsen, Chair | Robert Cucuzza

100 INTRODUCTION TO THE THEATER (UC:CSU) 3 UNITS

Prerequisite: None | Lecture 3 hrs

Focuses on the relationship of theater to various cultures throughout history, and on the contributions of significant individual artists. This course introduces students to elements of the production process including playwriting, acting, directing, design, and criticism. Students will also survey different periods, styles and genres of theater through play reading, discussion, films and viewing and critiquing live theater, including required attendance of theater productions.

110 HISTORY OF THE WORLD THEATER (UC:CSU) 3 UNITS

Prerequisite: English 28 or ESL 8 | Lecture 3 hrs

The study of the world history of theatre from its origins in Ancient Greece through the present day, across the globe. The history and development of theatre and drama are studied in relationship to geographical cultural, political and social conditions of the time. Plays are read for analysis of structure, plot, character and historical relevance.

114 SCRIPT STUDY FOR THEATER PERFORMANCE, PRODUCTION & APPRECIATION (CSU) 3 UNITS

Prerequisite: None | Lecture 3 hrs

Fully explore an in-depth methodology of reading, analyzing and understanding play scripts in a variety of genres and styles intended for production. Investigate techniques used to determine how to read a play for its structure, scrutinizing the playwright's methods of creating theater through plot, character and imagery, and understanding what scripts 'mean' to the professional theater artist and theater-goer as distinct from other forms of literature.

200 INTRODUCTION TO ACTING (UC:CSU) 3 UNITS

Prerequisite: None | Lecture 3 hrs

Introduction to the art and craft of acting through lecture and demonstration. Students will explore an awareness of self on stage through improvisations and character work; including scenes and monologues. Student will analyze scripts and critique plays.

271 INTERMEDIATE ACTING (UC: CSU) 2 UNITS

Prerequisite: Theater 200

Lecture 1 hr, Lab 2 hrs

Acting principles are expanded and applied in staged scenes. The emphasis of scenes is on comprehension, translation into meaningful dramatic action, and creation. The actor's self-awareness is explored and developed before a classroom audience.

272 INTERMEDIATE APPLIED ACTING 3 UNITS

Prerequisite: Theater 200

Lecture 2 hrs, Lab 4 hrs

Follows Acting I introduction to Acting and continues the exploration of theories and techniques used in preparation for the interpretation of drama through acting. The emphasis will be placed on deepening the understanding of the acting process through character analysis, monologues, and scenes.

291 REHEARSALS & PERFORMANCES I (CSU) 1 UNIT

Prerequisite: None | Lab 3 hrs

Students are actively involved in the production of a play to be presented before a public audience. All areas of the production process are incorporated including acting, design, stage management, technical theater and backstage crews, and house management.

292 REHEARSALS & PERFORMANCES II (CSU) 2 UNITS

Prerequisite: None | Lab 6 hours

Students are actively involved in the production of a play presented before a public audience. All areas of the production process are incorporated, including acting, stage management, technical theater and backstage crews, costumes, make up and house management. Students must be available to meet all scheduled technical rehearsal and performance dates.

NOTE: Students must participate in a mandatory audition and/or interview.

293 REHEARSALS & PERFORMANCES III (CSU) 3 UNITS

Prerequisite: None | Lab 9 hours

Provides instruction and supervised student participation at an advanced level in the rehearsals and performances of plays produced at LA Mission College. Areas of involvement include scenic, lighting, sound, and costume design; acting; technical production; and management; etc. Student must be available for rehearsals, production meetings, and performance and technical schedules.

300 INTRODUCTION TO STAGE CRAFT (UC: CSU) 3 UNITS

Prerequisite: None | Lecture 2 hrs, Lab 2 hrs

Survey of the technical phases of play production for scenery, properties, lighting, sound, costuming, and stage management and organization of stage activity.

310 INTRODUCTION TO THEATRICAL LIGHTING (UC: CSU) 3 UNITS

Prerequisite: None | Lecture 3 hrs

Introduces the student to all aspects of lighting for television, film, and stage. Practical experience and problem solving are highlighted, including the study of color, procedures, control, and safe handling of lighting equipment. Students must be available for rehearsals and performances.

Disciplines • Educational Programs • Course Descriptions

315 INTRODUCTION TO THEATRICAL SCENIC DESIGN (CSU) 3 UNITS

Prerequisite: Theater 100 | Lecture 3 hours

Explores the training, practice, and problem solving skills of designing scenery for the stage. Includes concept design development, construction and painting techniques, sketching and rendering media skills, and model making.

405 COSTUME DESIGN (CSU) 3 UNITS

Prerequisite: None | Lecture 3 hrs

A survey of historical periods and their application to the stage; an intensive study of costuming design for the stage; introduction to shop procedures; beginning principles and techniques of costume design including figure drawing, character analysis, and sewing.

450 BEGINNING STAGE MAKE-UP (CSU) 3 UNITS

Prerequisite: None | Lecture 2 hour, lab 2 hours

Instruction and practice in a lecture/laboratory setting in all phases of makeup specifically designed for theatrical use. Analysis of character, script and production analysis in terms of makeup style and design. Make-up is performed by the student on their own face.

185 DIRECTED STUDY (CSU) 1 UNIT

Provides opportunity for in-depth study of a chosen area of theatre arts on a contract basis, under the direction of a supervising instructor.

285 DIRECTED STUDY (CSU) 1 UNIT

Provides opportunity for in-depth study of a chosen area of theatre arts on a contract basis, under the direction of a supervising instructor.

385 DIRECTED STUDY (CSU) 1 UNIT

Provides opportunity for in-depth study of a chosen area of theatre arts on a contract basis, under the direction of a supervising instructor.



Faculty

Akl, Carole E.

Instructor of Mathematics
B.S., M.A., University of California,
Los Angeles

Avalos-Njie, Linda Marie

Instructor of Counseling
B.A., M.S., California State
University, Northridge

Barbato, Louise

English and Communication Studies
Department Chair
Professor of English
B.A., M.A., University of California,
Los Angeles
Ph.D., Dottore In Lettere, Universita
degli Studi, Padova, Italy

Bernal, Vilma

Business & Law Department Chair
Instructor of Business
B.A., Pepperdine University
M.B.A., Woodbury University

Bill, Emily B.

Assistant Professor of Psychology
B.A., University of California, San Diego
M.A., National University, San Diego

Biondo, Jill K.

Associate Professor of Sociology
B.A., University of California, Santa Barbara
M.A., California State University, Northridge

Bordbar, Jason

Instructor, Business Administration
M.B.A., Colorado State University
B.A., University of California Los Angeles

Brown, Stephen T.

Vice Chair of Biology
Instructor of Life Sciences
B.A., California State University, Northridge
Ph.D., University of California, Los Angeles

Bonilla, Diana I.

Instructor of Counseling
B.A., University of California, San Diego
M.A., San Diego State University

Cascione, Joe

Assistant Professor of Kinesiology
Head Coach Baseball
B.A., California Lutheran University
M.A., Walden University
Teaching Credential, California State
University, Northridge

Climo, Michael J.

Vice Chair and Associate Professor of
English as a Second Language
B.A., Sonoma State University
M.Ed., University of Nevada, Las Vegas

Cooper, Cindy

Vice Chair and Instructor of
Health, Kinesiology
B.A., M.A., California State
University, Northridge

Crozer, Karen J.

Instructor of English
B.A., Cedarville University
M.S., M.F.A., City College of New York
M.A., Ph.D., Claremont Grad. University

Cucuzza, Robert

Assistant Professor of Theater
B.F.A., Carnegie Mellon University
M.F.A., California Institute of the Arts

Dakdouk, Roula R.

Instructor of Mathematics
B.S., M.S., California State University,
Los Angeles

Daly, Carolyn

Vice Chair and Instructor of English
B.A., University of California, Berkeley
Ph.D., University of Southern California

De Silva, Lilamani

Professor of Child & Family Studies
B.A., M.A., Pacific Oaks College, Pasadena

Diaz-Cooper, Veronica

Instructor of English
B.A., M.A., California State University,
San Bernardino

Durukan, Ebru

Associate Professor of Political Science
B.A., Bilkent University
M.A., University of Nottingham
M.A., Ph.D., Claremont Graduate University

Echeverri, Angela C.

Professor of Life Sciences, Chemistry
B.S., M.S. University of Illinois at
Urbana-Champaign
Ph.D., University of California, Los Angeles

Eguaras, Louis J.

Instructor of Culinary Arts
B.A., Hospitality Restaurant Mgmt
New England Culinary Institute

Enos, Kelly William

Vice Chair of Administration of Justice
A.S., College of the Canyons
B.S., M.S., National University, San Diego

Escobar, Mario

Assistant Professor of Romance
Languages B.A., University of California, Los
Angeles M.A., Arizona State University

Fenton, Mike

Vice Chair of Chemistry
Instructor of Life Sciences, Chemistry
B.S., Ph.D., University of California,
Los Angeles

Folland, Thomas

Assistant Professor of Art History
B.F.A. Nova Scotia College of Art & Design,
Nova Scotia, Canada
I.S.P. Critical/Curatorial Studies,
Whitney Museum of American Art,
New York
M.A., Art History, University of
California, Riverside
Ph.D., Art History, University of
California, Los Angeles

Garza, David

Library Department Chair
Instructor of Library Science
B.A., California State University, Los Angeles
M.L.S., University of California, Los Angeles

Gomez, Aleida

Instructor of Counseling
B.A., M.S., California State
University, Northridge

Godjoian, Gayane

Professor of Chemistry
B.S. (ACS Certified), California State
University, Los Angeles
Ph.D., University of California Santa Cruz

Faculty

Grigoryan, Rita

Assistant Professor of Child & Family Studies
B.A., M.A., California State University, Northridge

Huynh, Huy (John)

Assistant Professor of Multimedia and Cinema
B.A., University of Houston
M.F.A., Florida State University

Jordan, David

Vice Chair and Professor of Law
B.A., Georgetown University
J.D., Loyola Law School

Kerwin, Barbara

Professor of Art
B.A., Washington State University
M.A., California State University, Los Angeles
M.F.A., Claremont Graduate University

Kourinian, Hripsime Christine

Instructor of Counseling
B.A., University of California, Los Angeles
M.S., University of La Verne

Kubicki, Paul C.

Associate Professor of Computer Science
B.S., California State University, Sacramento
MM III, CDB III Certified

Ladinsky, Gina

Assistant Professor of English
B.S., California State University, Long Beach
M.P.W., University of Southern California

Levy, Myriam M.

Associate Professor of Sociology
A.A., Los Angeles Valley College
B.A., M.A., California State University, Northridge

Livio, Diane L.

Instructor of Life Sciences
B.S., Ph.D., University of California, Irvine

Long, Margie L.

Vice Chair and Professor of Communication Studies
A.A, Spokane Community College
B.A., B.A., Gonzaga University
M.A., University of California, Davis

Loper, Sherrie

Assistant Professor of Counseling
B.A., M.S., California State University, Northridge

Luis, Cynthia

Assistant Professor of English as a Second Language
B.A., University of California, Los Angeles
M.A., University of Southern California

Maldonado, Jose A.

Vice Chair of Chicano Studies
Associate Professor of Chicano Studies, History
B.A., California State University, Northridge
M.A., Arizona State University

Mkrtchyan, Tigran

Instructor of Mathematics
B.S., M.S., Yerevan State University, Armenia
M.S., California State University, Northridge

Milke, Leslie

Health, Kinesiology & Athletics Dept. Chair
B.A., M.A., California State University, Northridge

Mohammadian, Parvaneh

Vice-Chair of Anatomy and Physiology and HOC/CNA/HHA Programs
Assistant Professor of Life Sciences
B.S., M.S. University of Erlangen-Nuremberg, Germany
Ph.D., University of Erlangen-Nuremberg, Germany

Morales, John J., Jr.

Chicano Studies Department Chair
Professor of Chicano Studies, History
B.A., California State Polytechnic University, Pomona
M.A., San Diego State University

Nerud, Steven

Instructor of Accounting/Finance
B.S., Arizona State University
M.B.A., Northwestern University

Park, Mi Chong

Counseling Department Chair
Associate Professor of Counseling
B.A., M.S., California State University, Northridge

Park, Riye

Assistant Professor of English as a Second Language
B.A., Santa Clara University
M.S., University of Southern California

Paulsen, Deborah R.

Arts, Media & Performance Dept. Chair
Professor of Art
A.A.S., Spokane Falls Community College
B.F.A., Eastern Washington University
M.F.A., Claremont Graduate University

Pazirandeh, Said

Physical Sciences Department Chair
Instructor of Physical Science, Chemistry
B.S., M.S., San Diego State University

Phares, D'Art

Vice Chair of African American Studies and History
Associate Professor of History
B.A., Pepperdine University, Malibu
M.A., University of California, Los Angeles

Prostak, Gary

ESL, DevCom, Learning Skills Dept. Chair
Professor of English as a Second Language
B.A., M.Ed., Worcester State University
MATESL, Simmons College

Pursley, Mark

Professor of Philosophy
B.A., Westmont College
M.A., Fuller Theological Seminary

Quinn, Ayra L.

Instructor of English
B.A., Loyola Marymount University
M.A., Ph.D., University of California, Riverside

Rains, Richard

Vice Chair of Astronomy, Physical Science and Physics
Professor of Physics, Astronomy
B.S., University of California, Los Angeles
M.S., California State University, Los Angeles
M.A., Mount Saint Mary's College

Ramirez, Jose Luis

Professor of Counseling
B.A., California State University, Northridge
M.S., University of LaVerne, Los Angeles

Raskin, Edward

Veteran Affairs
B.A., M.A., California State University,
Los Angeles

Rettke, Mari

Vice Chair and Assistant Professor of
Computer Science
B.A., California State University, Northridge

Reynolds, J. Michael

Department Chair and
Instructor of Life Sciences
B.S., M.S., Stanford University

Riesberg, Curt

Vice Chair and Assistant Professor of
Developmental Communications
B.A., University of Minnesota
M.A.T., Kent State University, Ohio
M.P.W., University of Southern California

Rodriguez, Patricia

Assistant Professor of Child Development
B.A., California State University, Northridge
M.A., Pacific Oaks College

Ruys, Steve

Athletic Director
Assistant Professor of Health, Kinesiology
Athletic Director
B.S., California Lutheran University
M.S., Fresno Pacific University

Samii, Bamdad

Instructor of Mathematics
B.S., M.S., California State
University, Northridge

Samplewala, Milan

Instructor of Computer Science
M.S. in Physics,
Bombay University, Mumbai
M.S. in Computer Science,
University of Nebraska, Lincoln.

Sanchez, Jesus

Instructor of Culinary Arts
A.S., Food Service Management & Related
Techniques, LAMC

Sargsyan, Emil

Instructor of Mathematics
B.A., University of California, Berkeley
M.A., University of California, Davis
M.A., Indiana University

Serda, Adam

Instructor of Counseling (DSPS)
M.S., B.S., Fresno State University
A.A., College of the Sequoias

Schwartz, Robert

Disability Specialist
Assistant Professor of Social Work
B.A., Macalester College
M.S.W., Augsburg College

Scheib, Jolie R.

Foreign Language Dept. Chair, Associate
Professor of Romance Languages
B.A., M.A., California State
University, Northridge
Ph.D., University of California, Los Angeles

Silva, Jose Trinidad

Instructor of Culinary Arts
B.A., Hospitality Restaurant Management
New England Culinary Institute

Silver, Janice G.

Department Chair and Associate Professor
of Child & Family Studies
B.Ed., University of Saskatchewan
Saskatoon, Canada
M.A., Pacific Oaks College, Pasadena

Smazenka, Robert L.

Vice-Chair of Mathematics
Professor of Mathematics
B.S., California State University, Northridge
M.S., California State University, Los Angeles
Ph.D., University of Southern California

Stage, Curtis

Vice Chair of Multimedia, Cinema,
and Photography
Professor of Multimedia
B.F.A., California State University, Long Beach
M.F.A., Claremont Graduate University

Waktola, Daniel

Assistant Professor of Geography
B.A., Addis Ababa University, Ethiopia
M.Sc., Wageningen University,
The Netherlands
Ph.D., Asian Institute of Technology, Thailand

Walker, Afri

Instructor of Counseling
B.A., University of California, Los Angeles
M.S., National University

Walker, Tashini N.

Instructor of Counseling
B.A., University of California, Los Angeles
M.S., California State University, Northridge

Williams, Christopher F.

Vice Chair and Associate Professor
of Psychology
B.A., M.Ed, Ed.D., Penn State University

Wong, Debby

Mathematics & Computer Science
Department Chair
Professor of Mathematics
B.S., M.S., California State
University, Pomona

Woodmansee, Joyce

Professor of Computer Applications
& Office Technologies
B.S., M.S., California State
University, Northridge

Yamada, Ryan N.

Instructor of Mathematics
B.S., University of Puget Sound
M.S., University of California, Riverside

Yun, Yoon

Vice Chair and Associate Professor
of Mathematics
B.A., M.S., California State
University, Northridge

Zaiens, Marie Elaina

Instructor of Developmental
Communications, English
B.A., Kean University
M.A., Claremont Graduate University

Zandalasini, Louis J.

Professor of Culinary Arts
B.S., Golden Gate University, San Francisco
M.Ed., California State
University, Northridge

Emeriti

Ackerknecht, Charles
1987-1999
Professor of Mathematics

Ayers, Donna
2001-2016
Library Department Chair Associate
Professor of Library Science

Bommer, Terry
1975-2010
Professor of Accounting

Bowman, Carla *
1976-1993
Math and Science Cluster Chair, Associate
Professor of Biology, Microbiology

Cantrell, Eloise Fernandez
1975-2011
Department Chair and Professor of
Family & Consumer Studies, Food Service
Management, Child Development

Casson, Edward B.
1988-2012
Professor of Library Science

Chow, Stanley
1992-2001
Professor of Accounting,
Business Management

Cook, Charles
1975-1983
Professor of Electronics

Dirks, Charles
1975-2009
Professor of Political Science

Dowd, Marie P.
1975-1992
Professor of Office Administration

Duffy, Lucille
1976-1983
Professor of Developmental Communications

Elkerdany, Mo K. *
2002-2011
Associate Professor of Biology

English, Teresa A.
2002-2013
Instructor of Developmental
Communications

Farren, Cornelius D. *
1985-1995
Professor of Philosophy

Fellows, Donald K. *
1975-1992
Professor of Geography

Fenyés, Maria
1982-2007
Natural Sciences Department Chair
Professor of Chemistry

Flood-Moreno, Patricia
1995-2014
Business & Law Dept. Chair
Professor of Computer Applications &
Office Technologies

Forbes, Cecile A.
1975-1983
Professor of English

Foster, Dudley E., Jr.
1975-2010
Professor of Music

Foster, Leslie
1996-2009
Professor of Mathematics

Frank, Sherrill J.
1975-2009
Professor of Computer Applications &
Office Technologies

Gallager, William
1977-1979
Assistant Professor of Philosophy

Garcia, Rudy
1996-2013
Instructor of Culinary Arts

Goad, Eunice
1975-1983
Professor of Mathematics

Godwin, Annabelle P. *
1975-1992
Professor of Child Development

Goldberg, Harlan
1990-2008
Professor of Humanities

Greenberg, Rayma
1975-1995
Library Department Chair
Professor of Library Science

Greene, Lois
1975-1992
Instructor of Child Development

Hoggatt, Clela P. Allphin
1975-1992
Professor of English

Jacobson, Marvin M.
1985-1994
Professor of Journalism

Jones, David
1975-2001
Assistant Professor of English

Johnson, Patricia D.
2004-2014
Professor of Psychology

Kalter-Flink, Joanne
1990-2009
Professor of Counseling

Kearney, John H.
1975-1984
Professor of Cooperative Education

Kellogg, Edmund
1985-1995
Professor of Law

Klitsner, John
1988-2013
Athletic Director

Lampert, Sandra
1975-2006
Professional Studies Department Chair
Professor of Family & Consumer Studies

La Rosa, Ralph

1992-2008
English Department Chair
Professor of English

Leeds, Rachel L.

1975-2006
Professor of Speech Communication

Levine, Stanley M.

1986-2008
Associate Professor of Humanities

Lopez, Benjamin

1976-1995
Professor of Spanish, French

Malki, Abdo

2001-2013
Professor of Mathematics

Manoogian, Lorraine

1999-2010
Instructor of Geography

McClain, Doris G. *

1975-1992
Professor of Child Development

McFerran, Douglas

1975-2003
Professor of Philosophy

Marek, Robert

1975-1986
Assistant Professor of Mathematics

Moss, David*

1975-1982
Professor of Sociology

Mucherson, George

1975-2001
Professor of Sociology

Orozco, John

1993-2008
English Department Chair
Professor of English

Pardess, David Forbes

1975-2012
Professor of Languages, Linguistics

Peterson, Delbert

1978-1995
Associate Professor of
Cooperative Education

Pitluck, Donna Mae

1975-1994
Professor of Library Science

Polk, Susan

1996-2014
Instructor of Developmental
Communications

Retig, Arthur C.

1986-1994
Professor of Electronics,
Vocational Education

Risemberg, Leon A.

1990-2006
Professor of Engineering

Ritcheson, Suzanne

1989-2011
Professor of Counseling

Rivera, Phoebe

1975-2009
Associate Professor of English, ESL,
Spanish, Linguistics

Ross, Febronia R.

1975-1991
Cluster A Chair
Professor of Romance Languages

Ruelas, Julie Ann *

1992-2011
Professor of Child Development

Rush, Cleveland

1975-2009
Associate Professor of
Business Administration

Scheib, Gerald*

1976-2001
Cluster and Dept. Chair Arts & Letters
Professor of Art

Schrier, Aaron

1976-2002
Professor of Counseling

Scuderi, Richard J.

1980-2009
Director of Disabled Student Programs
& Services

Silvers, Sally K.

1976-2001
Professor of Family & Consumer Studies,
Interior Design

Smith, Marshall L.

1975-1995
Professor of Biology

Suyama, Ruth

1975-2003
Professor of History

Thomsen, Sandy

1988-2014
Library Dept. Chair
Assistant Professor of Library Science

Torres, Andres R.

1975-1995
Professor of Speech

Wada, Junko J.

1995-2009
Professor of Child Development

Walker, Gwen

1978-2010
Professor of Counseling

Weidler, John*

1978-1988
Professor of Real Estate

Yguado, Alex

1975-2007
Professor of Economics

*Deceased

Glossary of Terms

Academic Probation

After attempting 12 units, a student whose cumulative grade point average falls below 2.00 is placed on academic probation. A student whose cumulative grade point average falls below 2.00 for three consecutive semesters is subject to dismissal from the college.

Academic Renewal

Previously recorded substandard academic performance, which is not reflective of the student's demonstrated ability, is removed from a student's academic record for the purpose of computing the grade point average.

Add Permit

A card issued by an instructor upon presentation of a valid identification card (ID Card) which permits the student to add the class if the instructor determines that there is room. Enrollment in the class is official only if the Add Permit is processed by Admissions and Records before the published deadline.

Admissions and Records

The office staff that admits students and certifies record of college work; also provides legal statistical data for the college

Administration

Officials of the college who direct and supervise the activities of the institution

Advisory

A class or skill you are advised to have, but not required to have, prior to enrolling in the target course

Application for Admission

A form provided by the college on which the student enters identifying data and requests admittance to a specific semester or session. A student may not register and enroll in classes until the application has been accepted and a Permit to register issued.

Articulation

An agreement with another institution which certifies that courses will be accepted for credit upon transfer

ASO

Organization to which all enrolled students are eligible to join called the Associated Student Organization

Associate Degree (AA or AS)

A degree (Associate in Arts or Associate in Science) granted by a community college, which recognizes a student's satisfactory completion of an organized program of study consisting of a minimum of 60 semester units

Bachelor's Degree (BA, AB, BS)

A degree granted by a four-year college or university which recognizes a student's satisfactory completion of an organized program of study consisting of 120 to 130 semester units

Career Education Certificate

A certificate granted by a community college which recognizes a student's satisfactory completion of an organized program of vocational study of 16 to 45 units

Career Program

A group of courses planned to lead to competency in a particular field of study and to either a Career Education Certificate or an AA Degree

Class Section

A group of registered students meeting to study a particular course at a definite time. Each section has a ticket number listed in the Schedule of Classes along with the scheduled time and place of the class meeting.

Concurrent Enrollment

Enrollment in one or more college classes while attending high school, or another educational institution. Also, enrollment in two or more classes during the same semester.

Continuing Student

A student registering for classes who attended the college during the previous semester. A student registering for the Fall semester is a continuing student if he or she attended the college during the previous Spring semester; attendance during the summer session is not included in this determination.

Corequisite

A class that must be taken simultaneously with the target course. A corequisite may be completed with passing grade ("C" or better) prior to enrollment in the target course.

Counseling

Guidance provided by professional counselors in collegiate, vocational, social, and personal matters

Course

A particular portion of a subject selected for study. A Course is identified by a Subject Title and Course Number; for example: Accounting 1.

Course Title

A phrase descriptive of the course content; for example, the course title of Accounting 1 is "Introductory Accounting I."

Glossary of Terms

Credit by Examination

Course or unit credit granted for demonstrated proficiency through testing

Dismissal

A student on academic or progress probation may be dismissed from the college. Once dismissed, the student may not attend any college within the Los Angeles Community College District for a period of one year and must petition for readmittance at the end of that period of time.

Dropping

The action a student takes in withdrawing his or her enrollment from one or more classes during a semester and continuing in other class(es). See "withdrawal."

Educational Program

A planned sequence of credit courses leading to a defined educational objective such as a Career Education Certificate or Associate Degree

Electives

Courses recommended for a given major in addition to prescribed requirements

Enrollment

That part of the registration process during which students select classes by ticket number to reserve a seat in a selected class and be placed on the class roster. A student may also enroll in a class by processing an Add Permit obtained from the instructor of the class.

Full-time Student

A student may be verified as a full-time student if he/she is enrolled and active in 12 or more units during the Fall or Spring semester.

General Education Requirements

These are also called Breadth Requirements, groups of courses selected from several disciplines, which are required for graduation.

Grade Points

The numerical value of a college letter grade: A-4, B-3, C-2, D-1, F-0

Grade Point Average

A measure of academic achievement used in decisions on probation, graduation, and transfer. The GPA is determined by dividing the total grade points earned by the number of attempted units.

Grade Points Earned

Grade points times the number of units for a class

INC – Incomplete

The administrative symbol "INC" is recorded on the student's permanent record in situations in which the student has not been able to complete a course due to circumstances beyond the student's control. The student must complete the course within one year after the end of the semester or the "I" reverts to a letter grade determined by the instructor. Courses in which the student has received an Incomplete ("INC") may not be repeated unless the "INC" is removed and has been replaced by a grade of "D" or "F." This does not apply to courses which are repeatable for additional credit.

IP – In Progress

An "IP" is recorded on the student's permanent record at the end of the first semester of a course that continues over parts or all of two semesters. A letter grade is recorded at the end of the semester in which the course ends.

Lower Division

Courses at the freshman and sophomore levels of college

Major

A planned series of courses and activities selected by a student for primary emphasis during the student's study at the college

Minor

The subject field of study which a student chooses for secondary emphasis

Module

A portion of a parent course offered for the benefit of students who may not be able to attempt the work of the entire course in one semester. Students should, when possible, attempt to complete all modules of a parent course in one year. A letter in the course number field identifies a module.

Non Degree Applicable

Category of courses called Non Degree Applicable. These classes are marked (NDA) in the Catalog and Schedule. Credit for these classes does not apply toward the AA or AS degree. These classes are not transferable.

Non-Penalty Drop Period

The first four weeks of a regular Fall or Spring semester during which a student's enrollment in a class is not recorded on the student's permanent record if the student drops by the deadline. This deadline will be different for short term and summer session courses.

Pass/No-Pass

A form of grading whereby a student receives a grade of P or NP instead of an A, B, C, D, or F. A "P" is assigned for class work equivalent to a grade of C or above.

Parent Course

A course which may be offered in modules. Credit for all modules of a parent course is equivalent to credit for the parent course. Parent courses are all courses without letters in the course number field.

Permit to Register

A form listing an appointment day and time at which the student may register. The permit is issued to all new students upon acceptance to the college, and to all continuing students.

Placement Tests

Tests given prior to admission, which are used to determine the student's assignment to the most appropriate class level

Prerequisite

A class or skill you must have prior to enrolling into the target class. The faculty of that discipline require the prerequisite because they feel it is necessary for you to succeed in the target course.

Progress Probation

After enrolling in 12 units, a student whose total units for which a W, NCR, or I has been assigned equals 50 percent or more of the units enrolled is placed on progress probation. A student whose cumulative number of units for which a W, NCR, or I has been assigned equals 50 percent or more for two consecutive semesters is subject to dismissal from the college.

Report Delayed (RD)

This temporary administrative symbol is recorded on the student's permanent record when a course grade has not been received from the instructor. It is changed to a letter grade when the grade report is received.

Registration

The process whereby a continuing student or a new or reentering student whose application has been accepted formally enters the college for a specific semester and receives an identification card (ID Card). The student may enroll in open classes as part of the registration process.

Returning Student

A student registering for classes who did not attend the college during the previous semester. A student registering for the Fall semester is a returning student only if he or she did not attend the college during the Spring semester; attendance during the summer session is not included in this determination.

Schedule of Classes

A booklet used during registration giving the Subject Title, Course Number, Course Title, Units, Time, Instructor, and Location of all classes offered in a semester

Semester

One half of the academic year, usually 18 weeks of instruction

Subject

A division into which knowledge is assembled for study, such as art, mathematics, or history

Subject Deficiency

Lack of credit for a course or courses required for some particular objective, such as graduation or acceptance by another institution

Transfer

Changing from one collegiate institution to another after having met the requirements for admission to the second institution

Transferable Units

College units earned through satisfactory completion of courses, which have been articulated with four-year institutions

Transcript

An official list of all courses taken at a college or university showing the final grade received for each course

Transfer Courses

Courses designed to match lower division courses of a four-year institution and for which credit may be transferred to that institution

Units

The amount of college credit earned by satisfactory completion of a specific course taken for one semester. Each unit represents one hour per week of lecture or recitation, or a longer time in laboratory or other exercises not requiring outside preparation.

Units Attempted

Total number of units in the courses for which a student received a grade of A, B, C, D, or F

Units Completed

Total number of units in the courses for which a student received a grade of A, B, C, D, F, or CR

Units Enrolled

Total number of units in which the student is enrolled at the end of the non penalty drop period, which is the total number of units for all courses appearing on the student's transcript

W

An administrative symbol assigned to a student's permanent record for classes which a student has dropped or has been excluded by the instructor after the end of the non-penalty drop date but before the last day to drop

Withdrawal

The action a student takes in dropping all classes during any one semester and discontinuing course work at the college

Index

Academic Affairs	37	Business	95	College Sheriff's Department	43
Academic Honors	44	Business & Fiscal Services	42	Communication Studies (formerly Speech)	107
Academic Probation & Dismissal	45	Cal Grant Program	30	Compliance Officer	62
Academic Standards	44	California Nonresident Tuition Exemption for Eligible California High School Graduates	18	Computer Applications & Office Technology	108
Access to Records	59	California Residence Requirements	18	Computer Science Information Technology	111
Accounting	84	California State Universities	78	Concurrent Enrollment	22, 47
Accuracy Statement	191	California State University System – General Education Plan	81	Consortium Agreement	28
Add a Class	23	CalWORKs (California Work Opportunity & Responsibility to Kids)	39	Cooperative Agencies Resources for Education (CARE)	26
Administration of Justice	85	Campus Map	Inside back cover	Cost Per Unit	22
Admissions & Registration Procedures	14	Campus Security	69	Counseling	113
Admission Eligibility	14	Cancellation of Classes	23	Counseling Office	24
Advanced Placement (AP) Information	49	Career and Technical Education (CTE)	40	Course Repetition & Activity Repetition	46
African-American Studies	87	Change of Enrollment Status	28	Credit by Examination	48
Allied Health	88	Change of Program	23	Credit for Courses Completed at Foreign Institutions	48
Anatomy	88	Chemistry	96	Credit for Courses Completed at Non-Accredited Institutions	47
Anthropology	88	Chicano Studies	97	Credit for Prerequisites	55
Application Process	15	Child Development	100	Crime Report	69
Art	88	Child Development Center	25	Criteria for Honors Certificates	45
Art History	92	Child Development Training Consortium	40	Culinary Arts	116
Associate Degree - General Education Requirements	73	Cinema	106	Dance Studies	123
Associate Degree for Transfer	82	CLEP (College Level Examination Program)	52	Dance Techniques	123
Associate in Arts/Associate in Science Degree Requirements	71	Closed Classes/No Standby List	23	Day & Extended Day Classes (Hours)	23
Associated Students Organization (ASO)	32	Clubs & Organizations	33	Degrees & Certificates	75
Associated Students Organization Fee	21	Code of Conduct Statement	12	Developmental Communications	124
Astronomy	92	College Advisory Committees	12	Directions to Mission College & Outreach Locations	190
Attendance	46	College as Non-Public Forum	64	Directory of College Services	183
Audited Classes	23, 28	College & High School	22	Disabled Students Programs & Services (DSPS)	25
Awarding Credit	47	College Colors & Theme	34	Disbursement of Financial Aid	28
Baking, Professional	92	College Facilities & Locations	13	Disciplines, Educational Programs & Course Descriptions	83
Basic Skills	93	College Goals	9	District Information	44
Biology	93	College History	8	District Policies	58
Bookstore/Eagles' Landing Student Store	42	College Mission Statement	9	Diversity Program	69
Buildings & Classrooms	184				

Index

Drop a Class	23	General Studies	135	Kinesiology Major	147
Drug-Free Environment	69	Geography	137	LA HI-TECH Regional Consortium	41
Duplicate Receipts	22	Geology	137	Law	147
Early Childhood Mentor Program	40	Getting Started	22	Learning Center (TLC)	37
Earth Science	124	Glossary of Terms	178	Learning Skills	149
Economics	125	Grades & Grade Changes	57	Liberal Studies	149
Education	125	Grading Symbols & Definitions	56	Library – An Instructional Service	38
Educational Philosophy, College	9	Graduation Honors	44	Library Science	149
Emeriti	176	Graduation Information/Requirements	70	Linguistics	149
English	126	Guardian Scholars Program	40	Linked Learning	41
English as a Second Language	128	Health	137	Los Angeles Community College District	2
Enrollment Fee	20	Health Occupations	138	LA Healthcare Competency-to-Career Consortium (LAH3C)	41
Environmental Science	131	Health Science	138	Lost & Found	43
EOPS (Extended Opportunity Program & Services)	25	Health Services Fees	21	Management	150
Faculty	173	History	139	Marketing	151
Faculty Ethics Statement	11	Honors Program	34	Mathematics	152
Family & Consumer Studies	131	Humanities	140	Matriculation	14
Family Child Care Homes Education Network (FCCHE)	40	Illegal File Sharing Policy	66	Microbiology	155
Family Educational Rights and Privacy Act (FERPA) Notification	59	Independent California Colleges & Universities	79	Multimedia Studies	156
Federal Financial Aid Programs	29	Institutional Learning Outcomes	9	Music	159
Fees & Costs	20	Instructional Materials	22, 58	Non-Credit Programs	31
Final Examinations	55	Instructional Television (ITV)	31	Non-Discrimination Policy	66
Finance	134	Intercollegiate Athletics	26	Nonresident	18
Financial Aid	26	Interior Design	141	Nonresident Tuition Fee	21
Financial Aid Satisfactory Academic Progress (SAP) Policy	30	International Baccalaureate	55	Notas de calificacion y cambios en las notas	57
Food Service Management	117	International Students Admissions	19	Nursing	160
Foster/Kinship Care Education (FKCE)	40	International Students Services (ISS)	24	Oceanography	161
Fraud	29	International Education Program – Study Abroad Classes	32	Off Campus Locations	190
French	135	Intersegmental General Education Transfer Curriculum (IGETC)	77, 80	Ombudsperson’s Role	68
Full-Time & Part-Time Students	23	Italian	144	Open Enrollment	23
Functions of the Community College	10	Journalism	144	Parking Fee	22
General Information	8	Jump Start on College	23	Parking Regulations	42
		Kinesiology (formerly Physical Education)	144	Partnering For Safety & Permanence – Model Approach to Partnerships In Parenting (PS MAPP)	41

Pass/No-Pass Options	55	Special Programs	31
Personal Development (See Counseling)	113	Standards of Student Conduct & Disciplinary Action	35, 62
Pharmacy Technician	161	State Financial Aid Programs	29
Philosophy	162	Statement of Philosophy	15
Photography	162	STEM Program	38
Physical Science	163	Student Activities	32
Physics	164	Student Education Planner	192
Physiology	164	Student Grievance Procedure	60
Political Science	165	Student Information	24
Politica De Abuso Sexual	66	Student Representation Fee	22
Politica No Discriminatoria	66	Student Responsibilities	28
Portuguese	166	Student Right-to-Know Disclosure	60
Prerequisites, Corequisites & Advisories	57	Students' Statements	58
Prerequisites Challenge Procedure	17	Student Services	24
Previously Earned College Units	48	Student Store, Eagles' Landing	42
Psychology	166	Student SSupport & Success Program	14
Publications	13	Student Trustee Election Procedure	34
Qualifications for ASO Officers	32	Suggested Study Load	23
Recording Devices in the Classroom	62	Table of Contents	5
Refund, Nonresident Tuition	21	Technical Stage Production	170
Refund Policy, Enrollment Fee	21	Telephone Extensions	4
Repeat Rule, Course	58, 74, 82	Theater	171
Residency Requirements	18	Theme, College	9
Return of Title IV Funds	28	Timeline & Deadlines	27
San Fernando Valley Scholars Network	41	Title V-HSI	38
Scholarships	30	Transcript & Verification Fees	22
Security Escort	69	Transcripts	57
Service Charge for Returned Checks	22	Transfer Center	26, 76
Sexual Assault	66	Transfer Information	76
Sexual Harassment Policy	66	Trio/Student Support Services (SSS)	41
Sheriff's Office, College	43	Values, College	9
Smoking Policy	69	Veteran Affairs Program	26
Sociology	168	Vision, College	9
Spanish	169	Withdrawal	58
Speech (see Communication Studies)	107	Workforce Development & Educational Programs	39

DIRECTORY OF COLLEGE SERVICES

Academic Affairs.....	818.364.7632
Admissions & Records.....	818.833.3322
Assessment Center	818.364.7613
Business Office	818.364.7600 x7110
CalWORKs	818.364.7760
Campus Security	818.364.7843
Career Center.....	818.833.3403
Child Development Center.....	818.364.7863
College Ombudsperson	818.364.7690
Counseling Department	818.364.7655 or 818.364.7656
Disabled Student Programs & Services (DSPS)	818.364.7732
Telecommunication Device for the Deaf (TDD)	818.364.7861
Eagles' Landing Student Store.....	818.364.7798
Extended Opportunity Program & Services (EOPS)	818.364.7645
English as a Second Language (ESL) Credit Program ...	818.364.7666 or 818.364.7722
English as a Second Language (ESL) Non-Credit Program...	818.364.7735
Financial Aid Office.....	818.364.7648
Health Center	818.362.6182
Honors/Transfer Alliance Program	818.364.7683
International Students	818.364.7741
ITV (Instructional Television)	818.364.3594
Learning Center	818.364.7756
Library.....	818.364.7600 x7106
President's Office	818.364.7795
Student Activities.....	818.364.7820
Student Services.....	818.364.7766
Transfer Center	818.364.7827
Veteran Resource Center.....	818.364.7658
Veterans Office.....	818.364.7864

Buildings & Classrooms

Center for Child Development Studies (CCDS)
Second Floor

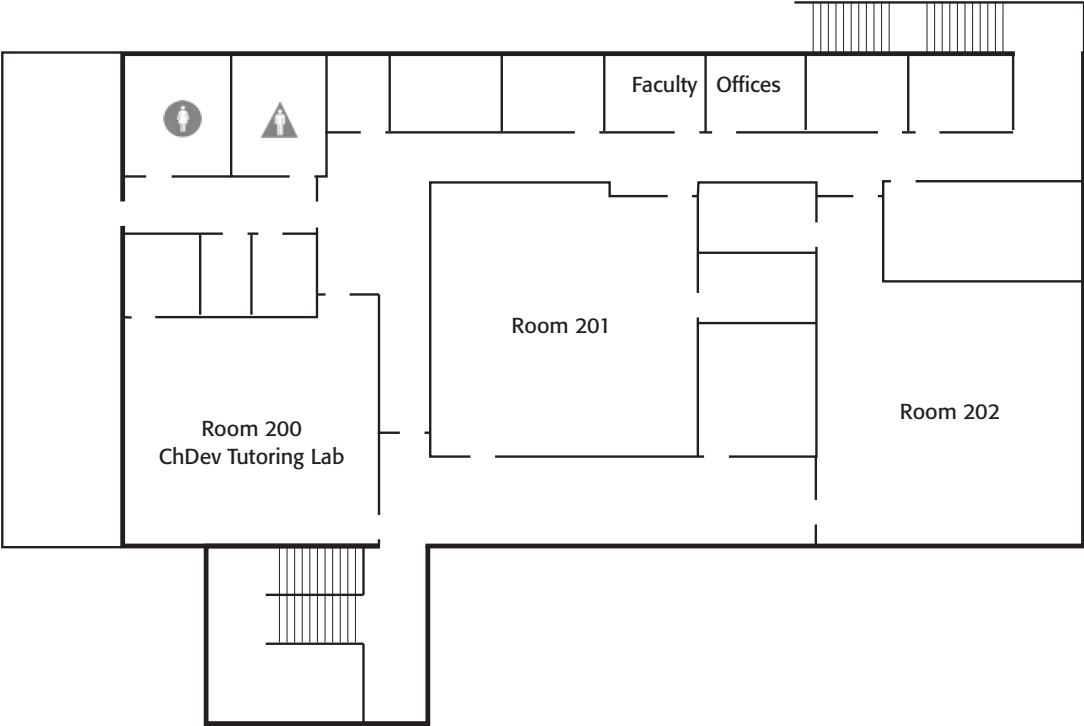

Buildings & Classrooms

**Culinary Arts Institute (CAI)
Upper Level**

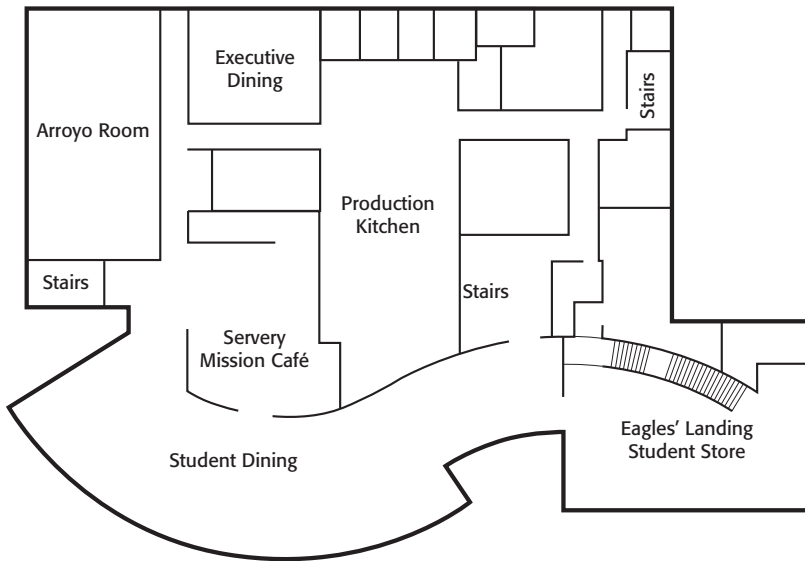
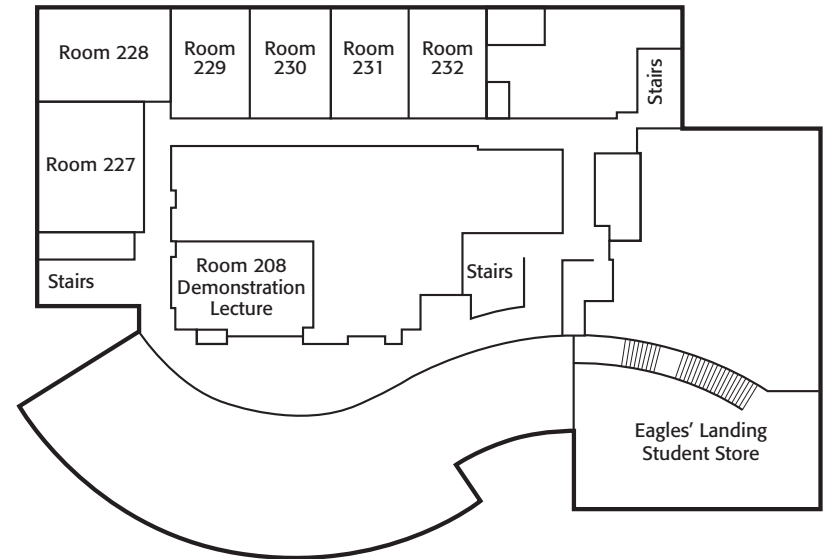

Main Level

Lower Level

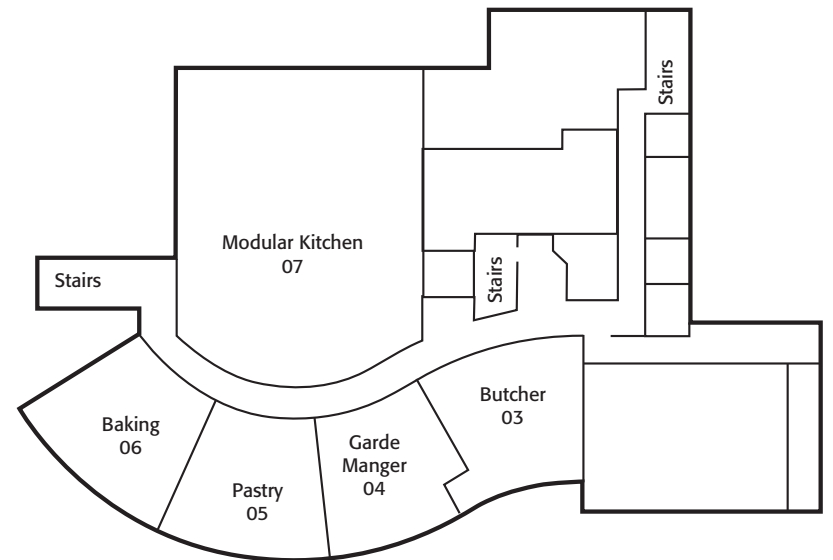

Buildings & Classrooms

Guadalupe S. Ramirez Collaborative Studies Building (CSB) Second Floor

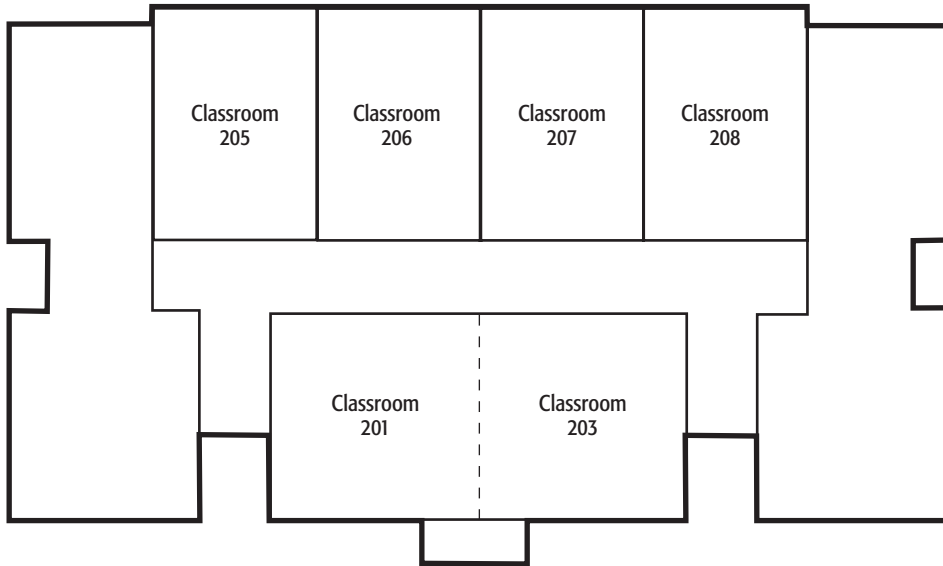

First Floor

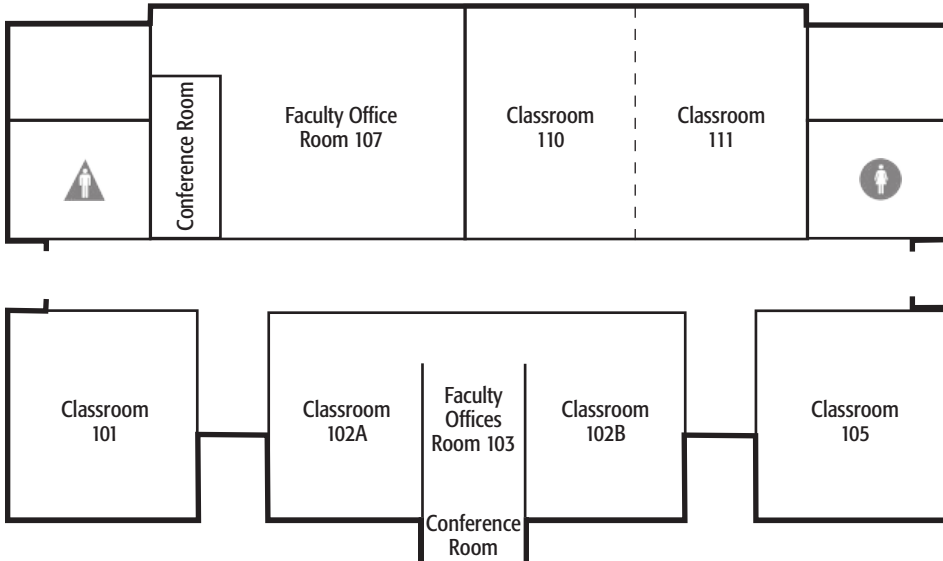

Buildings & Classrooms

**Campus Center Building (CMPC)
Second Floor - Ground level**

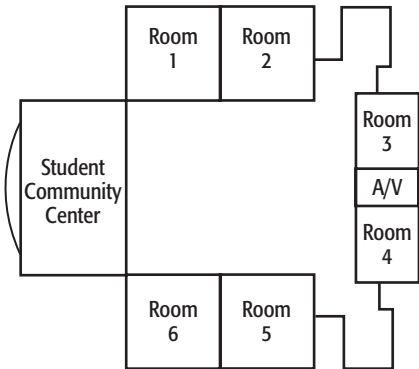

**Campus Center Building (CMPC)
First Floor - Lower level**

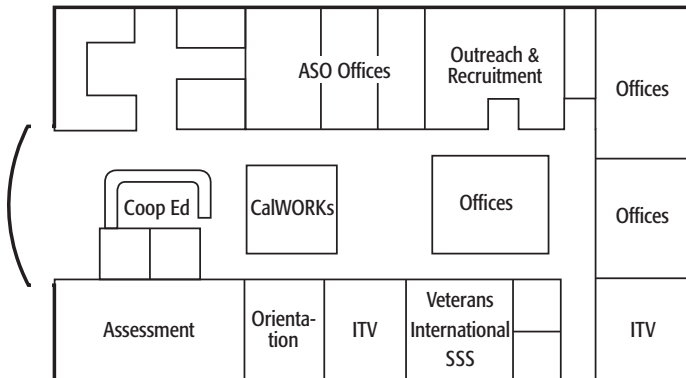

Instructional Building (INST) Second Floor

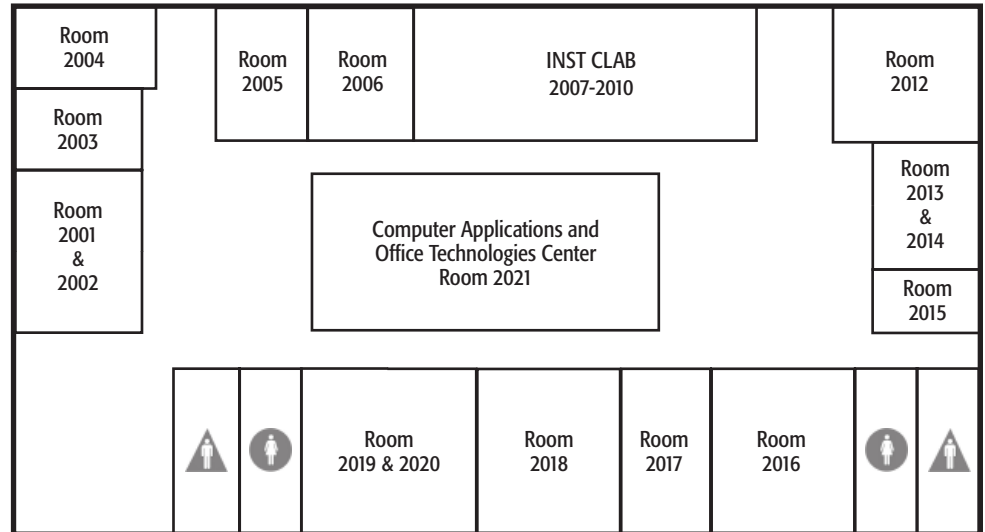

Instructional Building (INST) First Floor

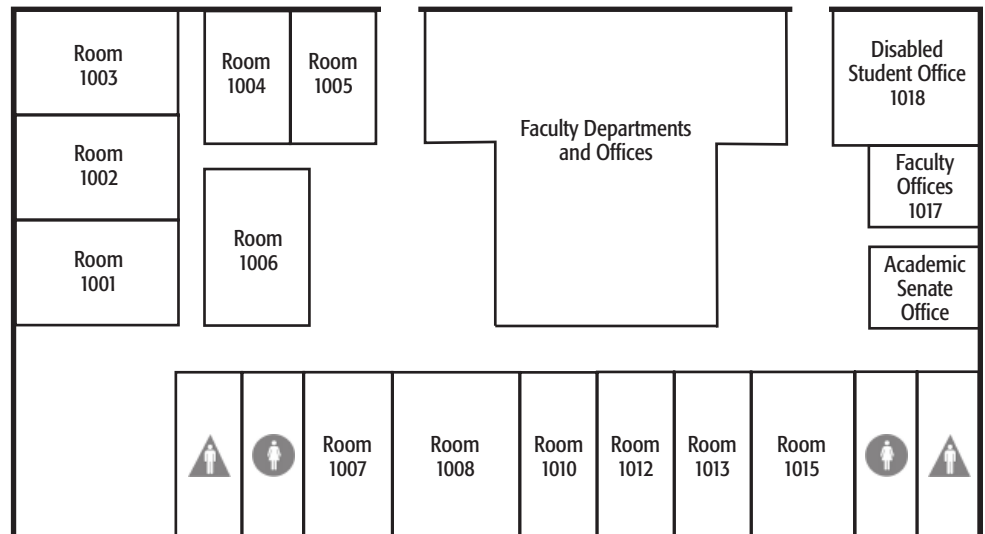

Buildings & Classrooms

Health, Fitness & Athletics Complex (HFAC) - **Second Floor** @ East Campus

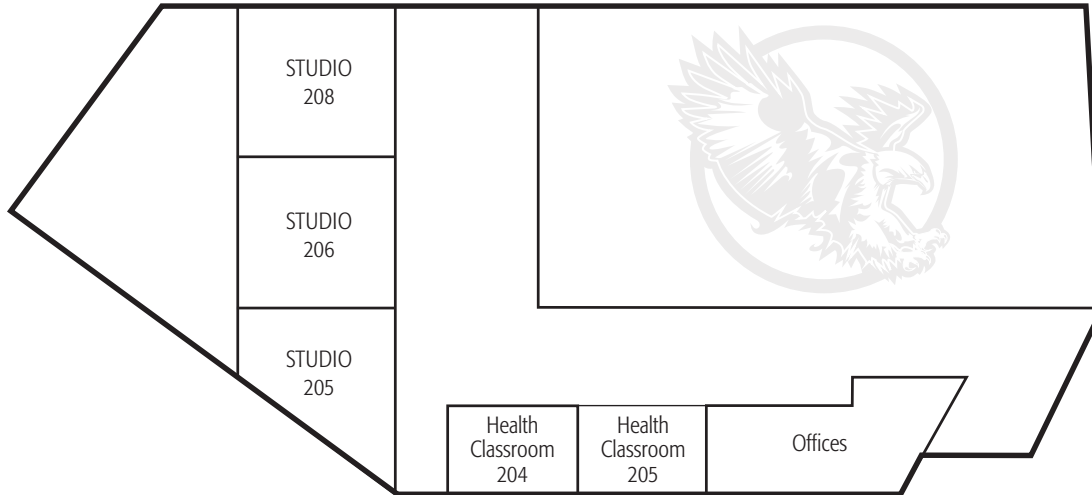

Health, Fitness & Athletics Complex (HFAC) - **First Floor** @ East Campus

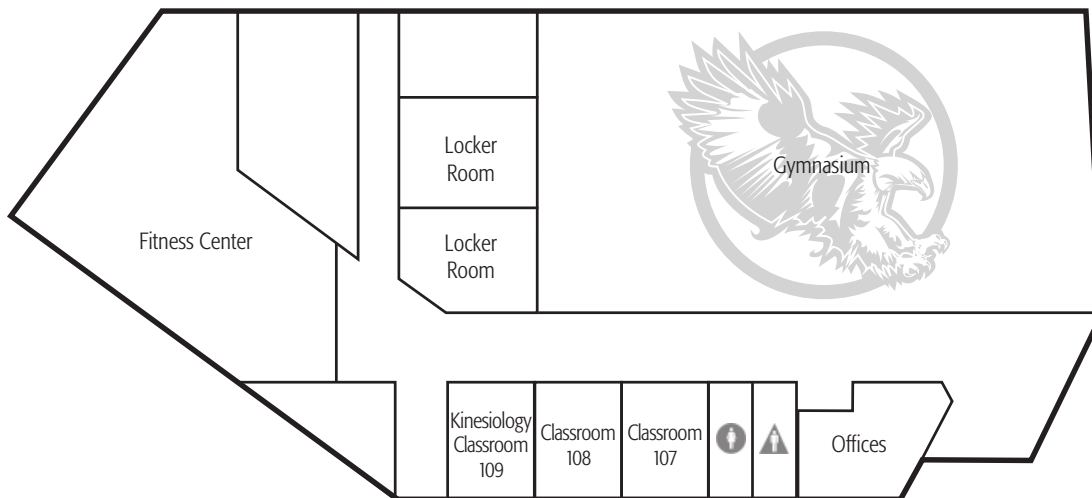

Buildings & Classrooms

Center for Math & Science (CMS) @ East Campus

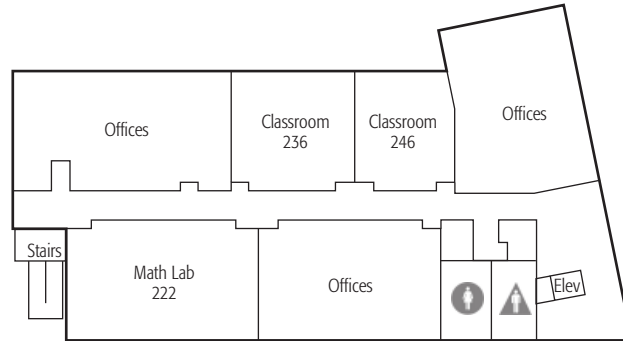
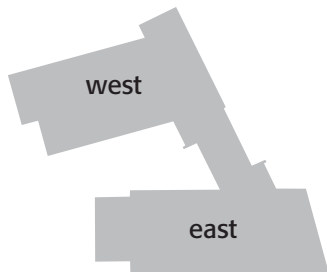

West ————— Upper Level ————— East

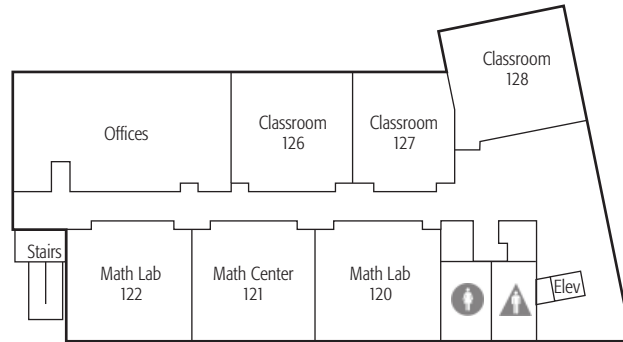
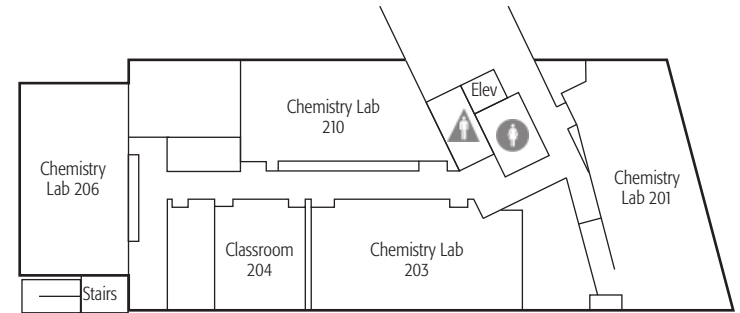

West ————— Main Level ————— East

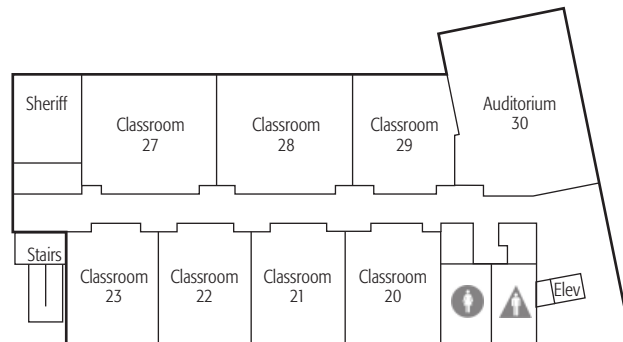
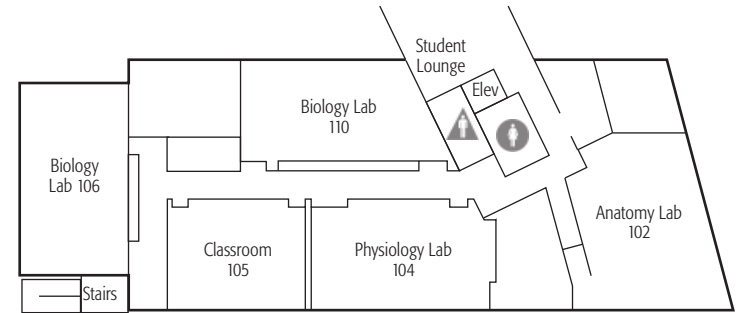

West ————— Lower Level ————— East

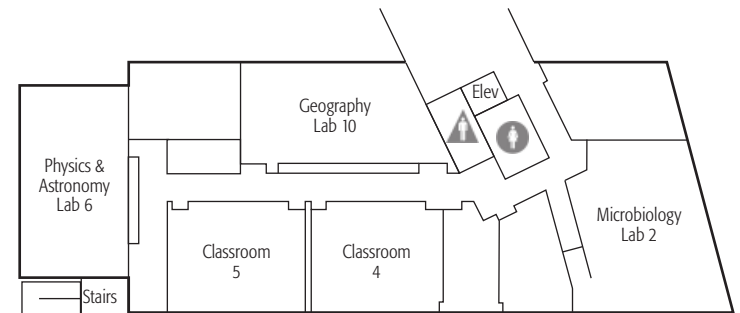

Off Campus Locations

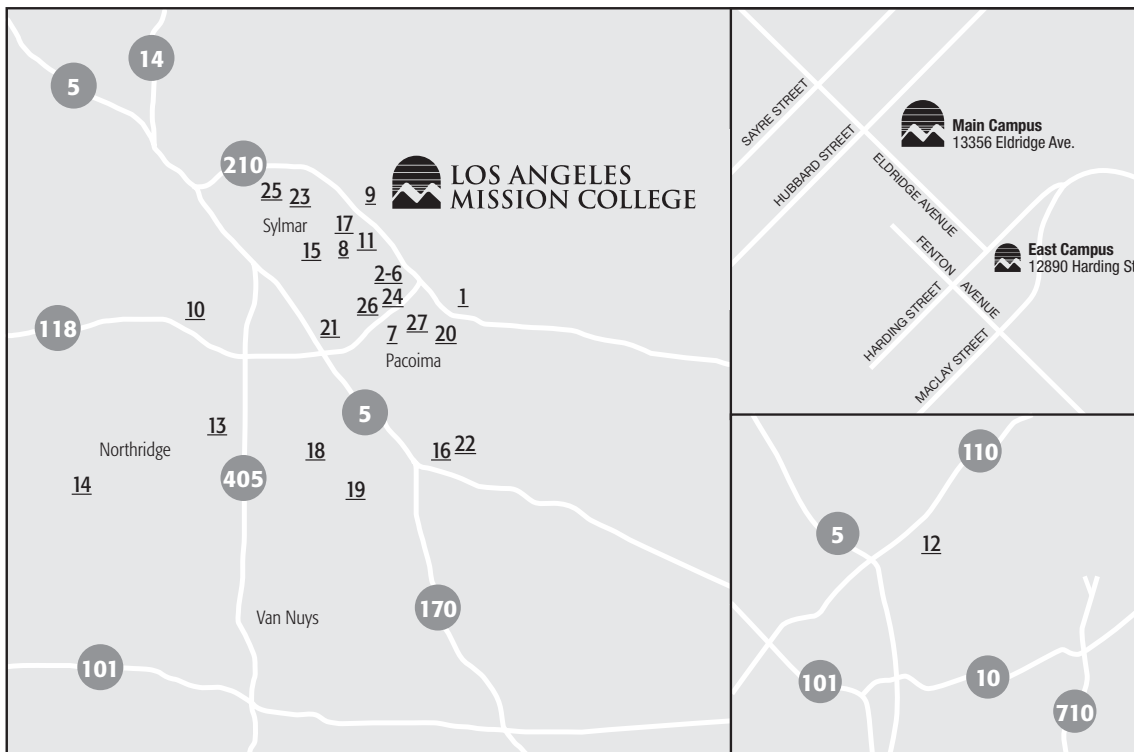

1. **CCEP HS**
Community Charter Early College HS
11500 Eldridge Ave, Lake View Terrace
2. **CCLA - ART**
Cesar Chavez Learning Academies
1001 Arroyo Ave, San Fernando
3. **CCLA - ASE**
Cesar Chavez Learning Academies -
Academy of Scientific Exploration
1001 Arroyo Ave, San Fernando
4. **CCLA - PC**
Cesar Chavez Learning Academies -
Parent Center
1001 Arroyo Ave, San Fernando
5. **CCLA - TPA**
Cesar Chavez Learning Academies -
Teacher Prep Academy
1001 Arroyo Ave, San Fernando
6. **CCLA - SJHS**
Cesar Chavez Learning Academies -
Social Justice
1001 Arroyo Ave, San Fernando
7. **EL NIDO**
El Nido - Pacoima Community Center
11243 Glenoaks Blvd, Pacoima
8. **GRID-ES**
Gridley Elementary School
1907 Eight St, San Fernando
9. **HUBB-ES**
Hubbard Elementary School
13325 Hubbard St, Sylmar
10. **KENN-HS**
John F. Kennedy HS
11254 Gothic Ave, Granada Hills
11. **LAKEVIEW**
Lakeview Charter HS
919 Eight St, San Fernando
12. **LA-LEAD**
Los Angeles Leadership Academy
234 E. Avenue 33, Los Angeles
13. **MONROE**
James Monroe HS
9229 Haskell Ave, North Hills
14. **NA HS**
Northridge Academy HS
9601 Zelzah Ave, Northridge
15. **NUEVA**
Nueva Esperanza Charter Academy
1445 Celis St, San Fernando
16. **NVM INST**
North Valley Military Institute
12105 Allegheny St, Sun Valley
17. **OFY-SYLMS**
Options for Youth Sylmar
13711 Foothill Blvd #B, Sylmar
18. **PCH**
Pacoima City Hall
13520 Van Nuys Blvd, Pacoima
19. **RANCHITO**
El Ranchito
7940 Ranchito Ave, Panorama City
20. **SAR-COUG**
Sara Coughlin Elementary
11035 Borden Ave, Pacoima
21. **SFDO-HS**
San Fernando HS
11133 O'Melverny Ave, San Fernando
22. **SUNVL-HS**
Sun Valley High School
9171 Telfair Ave, Sun Valley
23. **SYLM-HS**
Sylmar HS
13050 Borden Ave, Sylmar
24. **SYL-BIO**
Sylmar Biotechnology Academy
13050 Borden Ave, Sylmar
25. **TRIUMPH**
Triumph Charter High School
13361 Glenoaks Blvd, Sylmar
26. **VAUG CTR**
Vaugh Next Century Learning Center
11505 Herrick Ave, San Fernando
27. **VPC-HS**
Valley Public Charter High School
12513 Gain St, Pacoima

L.A. Mission College Location

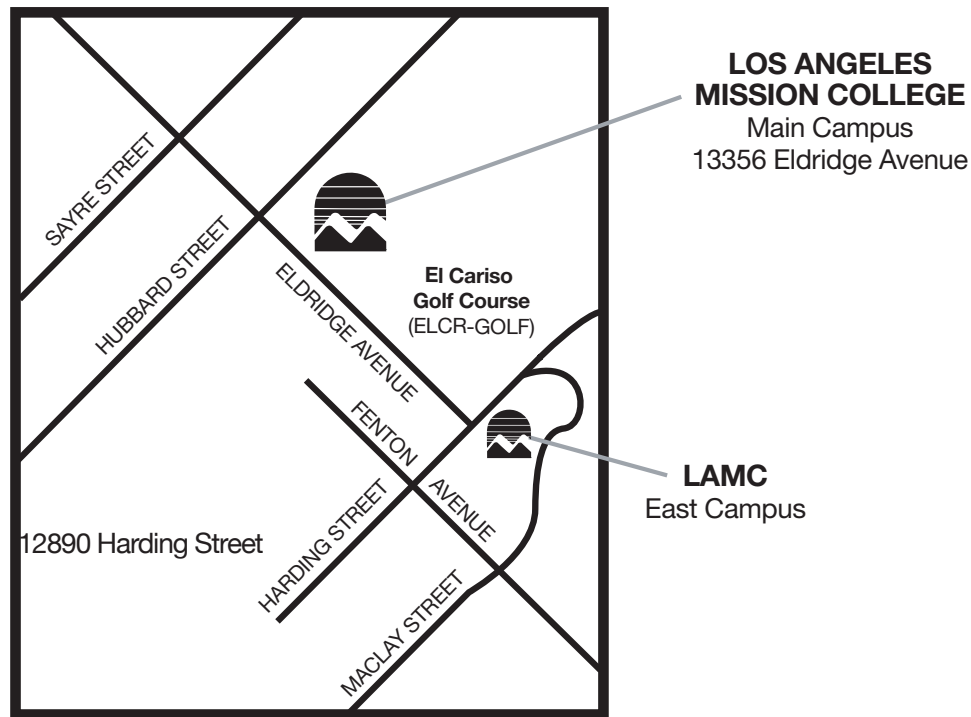

ACCURACY STATEMENT – The Los Angeles Community College District and Los Angeles Mission College have made every reasonable effort to determine that everything stated in this Catalog is accurate. Courses and programs offered, together with other matters contained herein, are subject to change without notice by the administration of the Los Angeles Community College District or Los Angeles Mission College for reasons related to student enrollment, level of financial support, or for any other reason, at the discretion of the District and the College Administration. The District and the College further reserve the right to add, amend, or repeal any of their rules, regulations, policies and procedures consistent with applicable laws.

Student Education Planner

Fall	Winter	Spring	Summer
COURSES		Units	Grade
TOTALS			

Fall	Winter	Spring	Summer
COURSES		Units	Grade
TOTALS			

Fall	Winter	Spring	Summer
COURSES		Units	Grade
TOTALS			

Fall	Winter	Spring	Summer
COURSES		Units	Grade
TOTALS			

Fall	Winter	Spring	Summer
COURSES		Units	Grade
TOTALS			

Fall	Winter	Spring	Summer
COURSES		Units	Grade
TOTALS			

Fall	Winter	Spring	Summer
COURSES		Units	Grade
TOTALS			

Fall	Winter	Spring	Summer
COURSES		Units	Grade
TOTALS			

Fall	Winter	Spring	Summer
COURSES		Units	Grade
TOTALS			

Fall	Winter	Spring	Summer
COURSES		Units	Grade
TOTALS			

Fall	Winter	Spring	Summer
COURSES		Units	Grade
TOTALS			

Fall	Winter	Spring	Summer
COURSES		Units	Grade
TOTALS			

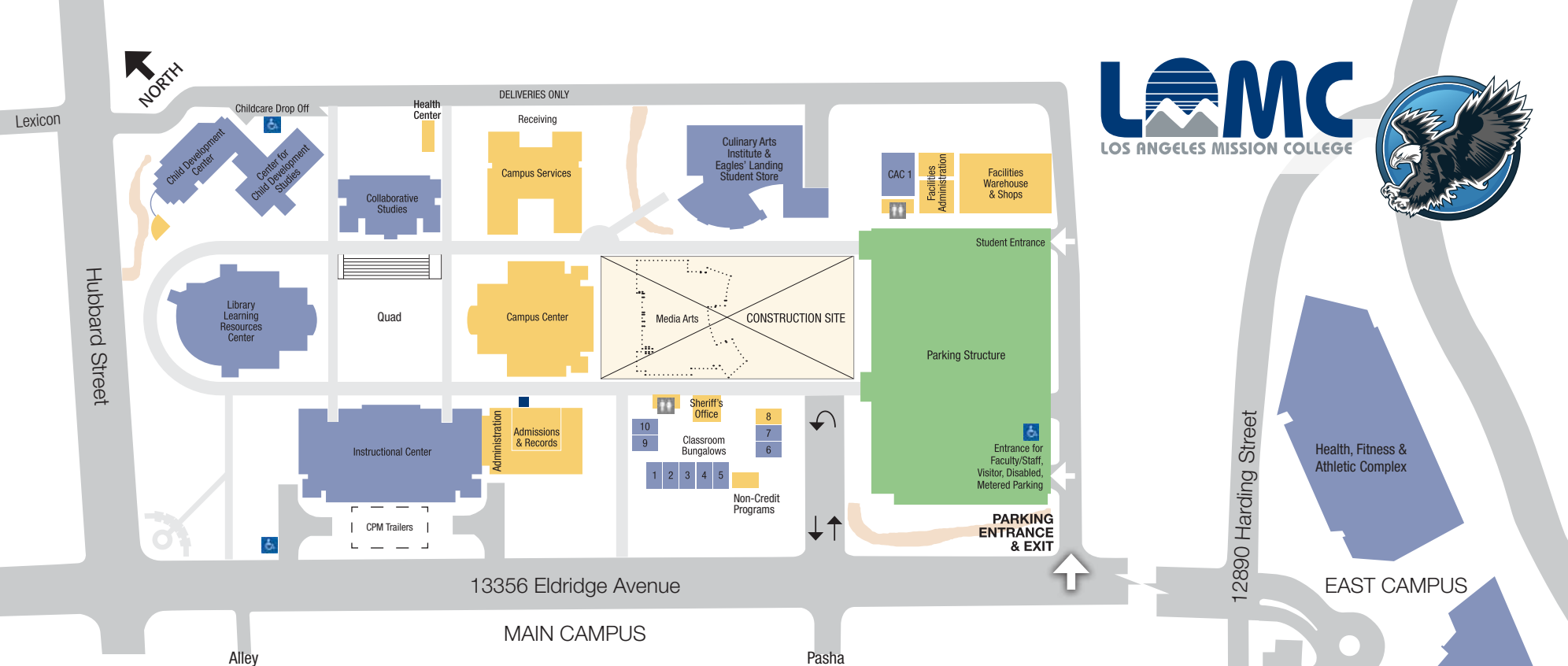

LIBRARY/LRC

- 1st Floor (Lower Level)*
 - Media Production Lab/Multimedia Labs
- 2nd Floor (Lower Level)*
 - Vice President of Student Services
 - Computer-Aided Instruction
 - Electronic Training Rooms
 - Learning Center
 - Teleconference Room
- 3rd Floor (Top Level)*
 - Library

CENTER FOR CHILD DEVELOPMENT STUDIES (CCDS)

- Child Development Center
- Classrooms 200-202
- FCCHN Office

INSTRUCTIONAL CENTER (INST)

- 1st Floor*
 - Classrooms 1001-1018
 - Disabled Student Services
 - Faculty Offices
- 2nd Floor*
 - Classrooms 2001-2021
 - Computer Science Lab
 - Computer & Office Applications Center

ADMINISTRATION WING

- Vice President of Academic Affairs
- Academic Affairs
- Information Booth
- Admissions & Records
- Counseling
- EOPS
- Financial Aid & Scholarships

COLLABORATIVE STUDIES (CSB)

- 1st Floor*
 - Classrooms 101-111
 - Faculty Offices
- 2nd Floor*
 - Classrooms 201-208

CAMPUS CENTER (CMPC)

- 1st Floor (Lower Level)*
 - Assessment & Orientation
 - ASO Office
 - International Students Office
 - ITV
 - Student Support Services Program
 - Veterans Office
- 2nd Floor (Ground Level)*
 - Assembly Area
 - Audio-Visual
 - Meeting Rooms 1-6
 - Student Community Center

CAMPUS SERVICES (CS)

- Office of the President
- Vice President of Administrative Services
- Business Office
- Fiscal Services
- Human Resources
- Mailroom
- Purchasing
- Receiving
- Reprographics
- Transfer Center

CULINARY ARTS (CAI)

- 1st Floor (Ground Level)*
 - Culinary Arts Institute
 - Eagles' Landing Student Store
- 2nd Floor (Top Level)*
 - Classrooms 208-232
 - Faculty Offices

CLASSROOM BUNGALOWS (BUNG)

- Bungalows 1-10
- Non-Credit Programs

FACILITIES SERVICES

- Plant Facilities

HEALTH, FITNESS & ATHLETICS COMPLEX (HFAC)

- 1st Floor (Lower Level)*
 - Classrooms 107-109
 - Fitness Center
 - Gym
- 2nd Floor (Ground Level)*
 - Classrooms 203-208
 - Faculty Offices

CENTER FOR MATH & SCIENCE (CMS)

- 1st Floor (Lower Level)*
 - Classrooms 2-29
 - Auditorium
- 2nd Floor (Ground Level)*
 - Classrooms 102-128
 - Math Center
- 3rd Floor (Top Level)*
 - Classrooms 201-246

EAST CAMPUS

Center for Math & Science

Health, Fitness & Athletic Complex

LOS ANGELES MISSION COLLEGE

13356 Eldridge Avenue

Sylmar, California 91342

818.364.7600 • 818.364.7861 tdd

www.lamission.edu



*Committed To A
Sustainable Tomorrow*

Please recycle this catalog

