

# Introductory Chemistry

## Laboratory Manual

Department of Chemistry  
East Los Angeles College

## Table of Contents

Topics	Page
Math Review	1 - 4
Density Measurement	5 - 8
Mixture Separation	9 - 11
Heat Capacity of Metals	12 - 15
Formula of a Hydrated Salt	16 - 19
Nomenclature	20 - 21
Formula of a Compound: Magnesium and Oxygen	22 - 25
Chemical Reactions	26 - 30
Determining the Reaction Yield	31 - 32
Flame Test	33 - 38
Charles Law	39 - 43
The Shape of Molecules	44 - 46
Compounds in Solution	47 - 50
Titration	51 - 54

Name: \_\_\_\_\_

## Math Review

**Part A: Solve each of the following expressions for x.**

1.  $2x - 25 = 8$

2.  $3x = 4y + 8$  (if  $y = 2$ )

3.  $8x + 5y - z = 0$  (if  $y = 4$  and  $z = -1$ )

4.  $H = W Q x$

5.  $Y = \frac{(T + 8)}{x}$

6.  $x + 6 = 23FG$

7.  $\frac{C^2 D^5 x}{E^4 R} = \frac{T^3 K}{Y}$

**Part B: Express each of the following in standard numerical form.**

1.  $7.2 \times 10^3$

5.  $2.6 \times 10^1$

2.  $9.35 \times 10^{-4}$

6.  $4.852 \times 10^2$

3.  $8.3 \times 10^{-2}$

7.  $8.57 \times 10^{-1}$

**Part C: Express each of the following in scientific notation.**

1. 87,000

5. 2547

2. 0.00035

6. 0.0053

3. 280

7. 0.013254

Name: \_\_\_\_\_

**Part D: Complete the following calculations. Include units on your answers. Report your answer to 1 decimal place.**

1.  $\frac{100 \text{ m}}{26 \text{ s}}$

6.  $\frac{8.1 \text{ kg}}{(0.45 \text{ cm} \times 0.55 \text{ cm})}$

2.  $(5.1 \text{ m})(4.5 \text{ m})$

7.  $0.45 \text{ mm} \times 0.28 \text{ mm} \times 0.85 \text{ mm}$

3.  $\frac{58 \text{ g}}{4 \text{ L}}$

8.  $\frac{75 \text{ kg}(5.0 \text{ m})}{(2.5 \text{ s})(6.0 \text{ s})}$

4.  $(34 \text{ cm})(21 \text{ cm})(8 \text{ cm})$

9.  $\frac{26000 \text{ J}}{125 \text{ g}}$

5.  $\frac{12500 \text{ J}}{(106 \text{ g})(4 \text{ C})}$

10.  $\frac{1.35 \text{ mol}}{3.55 \text{ L}}$

**Part E Simplify the following expressions.**

1.  $(4f + 13g)(2w)$

4.  $5 \frac{(5y - 4y)}{10}$

2.  $\frac{100 \times 5 \times 11}{(18)(2)}$

5.  $4d(6d)(0.25d)$

3.  $\frac{6a \times 5b^2}{3a^3}$

6.  $\frac{(2a - 3b)(3b)}{3cx}$

Name: \_\_\_\_\_

**Part F: Write the number of significant figures in the blank preceding the number.**

1. \_\_\_\_\_ 23

9. \_\_\_\_\_ 14.380

2. \_\_\_\_\_ 1.498

10. \_\_\_\_\_ 307

3. \_\_\_\_\_ 248.3

11. \_\_\_\_\_ 1.40082

4. \_\_\_\_\_ 107 cars

12. \_\_\_\_\_ 0.00058900

5. \_\_\_\_\_ 0.238

13. \_\_\_\_\_ 4500

6. \_\_\_\_\_ 8.0335

14. \_\_\_\_\_ 350,000

7. \_\_\_\_\_ 0.05587

15. \_\_\_\_\_ 180.00

8. \_\_\_\_\_ 14.809

16. \_\_\_\_\_ 3.50

**Part G: Compute the following. Use significant figures.**

1.  $(6.02 \times 10^{23}) (8.65 \times 10^4)$

7.  $\frac{(5.4 \times 10^4) (2.2 \times 10^7)}{4.5 \times 10^5}$

2.  $(6.02 \times 10^{23}) (9.63 \times 10^{-2})$

8.  $\frac{(6.02 \times 10^{23}) (-1.42 \times 10^{-15})}{6.54 \times 10^{-6}}$

3.  $\frac{5.6 \times 10^{-18}}{8.9 \times 10^8}$

9.  $\frac{(6.02 \times 10^{23}) (-5.11 \times 10^{-27})}{-8.23 \times 10^5}$

4.  $(-4.12 \times 10^{-4}) (7.33 \times 10^{12})$

10.  $\frac{(3.1 \times 10^{14}) (4.4 \times 10^{-12})}{-6.6 \times 10^{-14}}$

5.  $\frac{1.0 \times 10^{-12}}{4.2 \times 10^{-6}}$

6.  $(-3.2 \times 10^{-5}) (-8.6 \times 10^{-9})$

Name: \_\_\_\_\_

**Part H**

*Below are some conversion factors used in the SI System, and which we will use in this class.*

<u>kilo- = 1000</u>	<u>centi- = 1/100</u>	<u>milli- = 1/1000</u>	<u>Other</u>
<b><u>Conversions</u></b>			
1 kg = 1000 g		1000 mg = 1 g	1 mL = 1 cm <sup>3</sup>
1 km = 1000 m	100 cm = 1 m	1000 mm = 1 m	1 L = 1 dm <sup>3</sup>
		1000 mL = 1 L	1 cm = 10 mm

*Solve each of the following problems. Show the correct set-up and always use units.*

1. Determine the number of mm in 2400 m.
2. Determine the number of m in 6300 mm.
3. Determine the number of mm in 14.3 cm.
4. How many seconds are in 6.3 years?
5. Convert 3245 cm<sup>3</sup> to liters.
6. A metallurgist is making an alloy that consists of 543 g of chromium (Cr) and 4.5 kg of iron (Fe). Find the total mass of the mixture in kg.
7. How many mL of water (H<sub>2</sub>O) will it take to fill a 2.0 L bottle that already contains 1.25 L of H<sub>2</sub>O?
8. The density of lead (Pb) is 11.34 g/cm<sup>3</sup>. Find the density of Pb in kg/dm<sup>3</sup>.

Name: \_\_\_\_\_

## Density Measurement

**Purpose:** Learn how to make density measurements.

### Procedure:

#### Part A. Density of Deionized Water

1. Measure the mass of a 150 mL beaker on a balance.
2. In a 250 mL beaker, fill it about half full with deionized water.
3. Transfer about 9 mL of deionized water from the 250 mL beaker to a 10 mL graduated cylinder and record the actual volume.
4. Transfer all the deionized water from the 10 mL graduated cylinder to the measured 150 mL beaker, re-weigh, and record the total mass. This is your first trial.
5. Without discarding the deionized water from the 150 mL beaker, more deionized water will be added by repeating steps 3-4. This is your second trial.

#### Part B. Density of Unknown Liquid

1. Measure the mass of a 150 mL beaker on a balance.
2. Choose an unknown liquid and record its unknown number and/or letter, and transfer about 10 mL of the unknown liquid into a 50 mL graduated cylinder and record the actual volume.
3. Transfer all the unknown liquid from the 50 mL graduated cylinder to the measured 150 mL beaker, re-weigh, and record the total mass. This is your first trial.
4. Without discarding the unknown liquid from the 150 mL beaker, more of the same unknown liquid will be added by repeating steps 2-3. This is your second trial.
5. Discard the unknown liquid down the sink.

#### Part C. Density of Unknown Metal

1. Choose an unknown metal cylinder and record its unknown number and/or letter.
2. Measure the mass of the unknown metal cylinder on a balance.
3. In a 50 mL graduated cylinder, fill it about half full with deionized water and record its volume. This is the initial volume.
4. Slightly tilt the 50 mL graduated cylinder and slowly slide the unknown metal cylinder into the 50 mL graduated cylinder.
5. Record the new volume of deionized water in the 50 mL graduated cylinder. This is the final volume. This is also your first trial.
6. Using another unknown metal cylinder from the same unknown container, repeat steps 1-5 for your second trial.

Name: \_\_\_\_\_

**Report:**

**Part A. Density of Deionized Water**

	Trial 1	Trial 2
Mass of beaker	_____	_____
Mass of beaker + water	_____	_____
Mass of water	_____	_____
Volume of water	_____	_____
Density of water	_____	_____

Show calculation for the density of water:

Average density of water \_\_\_\_\_

Was the density of water the same in the two trials? If not, what could have caused the difference?

Between the two trials, which density value is correct?

Name: \_\_\_\_\_

**Part B. Density of Unknown Liquid**

Unknown number and/or letter

\_\_\_\_\_

Trial 1

Trial 2

Mass of beaker

\_\_\_\_\_

\_\_\_\_\_

Mass of beaker + unknown liquid

\_\_\_\_\_

\_\_\_\_\_

Mass of unknown liquid

\_\_\_\_\_

\_\_\_\_\_

Volume of unknown liquid

\_\_\_\_\_

\_\_\_\_\_

Density of unknown liquid

\_\_\_\_\_

\_\_\_\_\_

Show calculation for the density of unknown liquid:

Average density of unknown liquid

\_\_\_\_\_

Name: \_\_\_\_\_

### Part C. Density of Unknown Metal Cylinder

Unknown number and/or letter	_____	
	Trial 1	Trial 2
Mass of unknown metal cylinder	_____	_____
Initial volume of water	_____	_____
Final volume of water	_____	_____
Volume of unknown metal cylinder (by water displacement)	_____	_____
Density of unknown metal cylinder	_____	_____

Show calculation for the density of unknown metal cylinder:

Average density of unknown metal cylinder \_\_\_\_\_

Identity of unknown metal cylinder \_\_\_\_\_

Select from the following:

Aluminum, Density =  $2.70 \text{ g/cm}^3$

Iron, Density =  $7.87 \text{ g/cm}^3$

Copper, Density =  $8.96 \text{ g/cm}^3$

From the experiment, was your unknown metal cylinder's average density value lower, higher, or the same as one of the given values? If not the same as the given values, explain what could have caused your density value to be lower or higher?

Name: \_\_\_\_\_

## Mixture Separation

**Purpose:** Learn how to separate a mixture and identify the individual substances of the mixture.

### Procedure:

#### Part A. Solubility

1. Obtain 6 test tubes.
2. Using masking tape, label each test tube as follows:  
Test tube 1: sand + water  
Test tube 2: salt + water  
Test tube 3: salicylic acid + water  
Test tube 4: sand + ethanol  
Test tube 5: salt + ethanol  
Test tube 6: salicylic acid + ethanol
3. Add a small amount (an amount the size of the head of a cotton swab) of sand, salt, and salicylic acid to each corresponding test tube as labeled.
4. Add about 1 to 2 mL of water and ethanol to each corresponding test tube as labeled.
5. Mix each test tube and observe whether each substance (sand, salt, and salicylic acid) is soluble in water and/or ethanol. Record your observations.

#### Part B. Mixture Separation

1. Choose an unknown mixture and record its unknown number and/or letter.
2. Add about 0.75 to 1 g of the unknown mixture to a test tube.
3. Add about 5 to 6 mL of ethanol to the test tube and mix to potentially dissolve any ethanol-soluble substance(s).
4. Obtain a circular filter paper and fold it as shown in Figure 1 (a) thru (e), open it into a conical shape, and place it into a conical funnel (f).

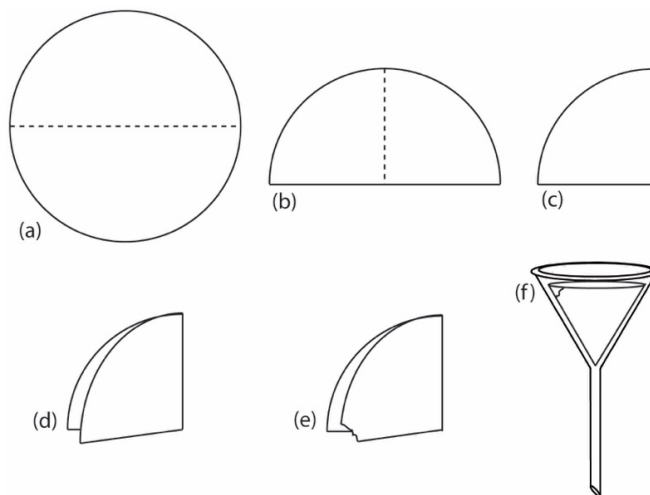

Figure 1

Name: \_\_\_\_\_

- Suspend the conical funnel over an Erlenmeyer flask as shown in Figure 2 below. A clay triangle may be used if the iron ring is too large to suspend the conical funnel.

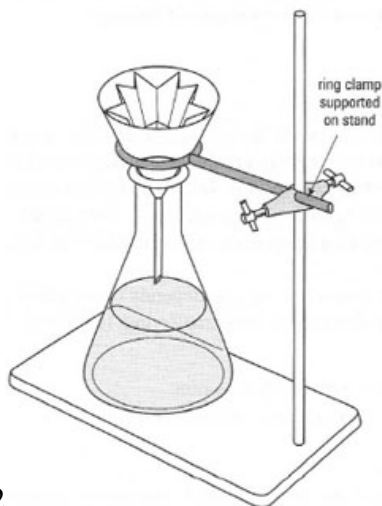

Figure 2

- Pour the unknown mixture from the test tube down the center of the filter paper. The filtrate will be collected in the Erlenmeyer flask.
- Add about 2 to 3 mL of **ethanol** to into the filter paper.
- Pour the filtrate from the Erlenmeyer flask into an evaporating dish.
- Using the energy from steam, evaporate the **ethanol** from the evaporating dish according to the setup as in Figure 3 below.

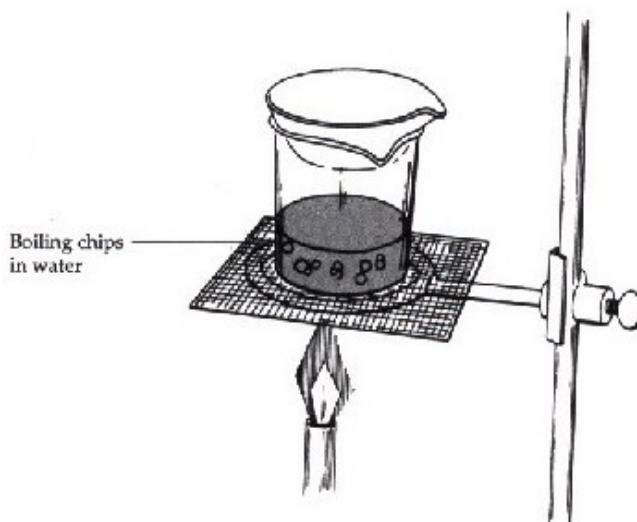

Figure 3

- Place an Erlenmeyer flask below the conical funnel, and slowly add about 5 to 6 mL of **hot deionized water** into the center of the filter paper in the conical funnel.
- Pour the filtrate from the Erlenmeyer flask into a clean evaporating dish.
- Using the energy from steam, evaporate the **deionized water** from the evaporating dish according to the setup as in Figure 3.

Name: \_\_\_\_\_

**Report:**

**Part A. Solubility**

Indicate, yes or no, if any of the substances is soluble in **water**:

Sand \_\_\_\_\_ Salt \_\_\_\_\_ Salicylic Acid \_\_\_\_\_

Indicate, yes or no, if any of the substances is soluble in **ethanol**:

Sand \_\_\_\_\_ Salt \_\_\_\_\_ Salicylic Acid \_\_\_\_\_

**Part B. Mixture Separation**

In **step 8**, does your filtrate contain a water-soluble and/or ethanol-soluble substance?

If a solid residue remains after ethanol evaporation in **step 9**, is the residue sand, salt, or salicylic acid?

In **step 10**, does your filtrate contain a water-soluble substance?

If a solid residue remains after water evaporation in **step 12**, is the residue sand, salt, and/or salicylic acid?

Unknown number and/or letter \_\_\_\_\_

Indicate, yes or no, if any of the substances was a component of your unknown mixture.

Sand \_\_\_\_\_ Salt \_\_\_\_\_ Salicylic Acid \_\_\_\_\_

Name: \_\_\_\_\_

## Heat Capacity of Metals

### PART A. Specific Heat Capacity of Copper

1. Fill a 600 mL beaker half-way with deionized water and bring it to a boil.
2. Obtain a calorimeter and determine its mass.
3. Fill the calorimeter half-way with deionized water.
4. Reweigh the calorimeter.
5. Obtain the temperature of the water inside the calorimeter.
6. Obtain a piece of copper and determine its mass.
7. Gently slide the copper rod into a large test tube (best to do this at a slight angle). Place the test tube inside the boiling water. The level of the boiling water should always be higher than that of the copper rod. Do not allow for water to enter the test tube. Heat for 10 minutes.
8. Obtain the temperature of the boiling water after the 10 minutes have elapsed. Ensure that the thermometer bulb does not touch the walls of the beaker or test tube.
9. Using a test tube holder, remove the test tube from the water bath and transfer the copper rod into the calorimeter. Be careful not to allow any water from the outside of the wet test tube to drip into the calorimeter. Do not allow any water from the calorimeter to splash out during transfer. Use a glass rod to help guide the copper, if necessary.
10. Immediately place the cover on top of the calorimeter. Insert a thermometer, being sure that the thermometer comes in contact with the water but not the metal. When the temperature reaches a maximum, usually after 1-2 minutes, record the temperature.
11. If directed by your instructor, carry out a second trial.
12. Thoroughly pat dry the copper rod with a paper towel. Return the used copper to the appropriate container.

### Part B. Specific Heat Capacity of an Unknown Metal

1. Repeat Part A. In place of copper, use a metal from one of the unknown containers. Be sure to record the letter of your unknown.

Name: \_\_\_\_\_

**Part A Data**

**Trial 1**

**Trial 2**

Mass of calorimeter	_____	_____
Mass of calorimeter and water	_____	_____
Initial temperature of water inside calorimeter	_____	_____
Mass of copper	_____	_____
Temperature of boiling water bath after 10 minutes	_____	_____
Highest temperature of water with copper inside calorimeter	_____	_____

**Part A Calculations. Show your work.**

1. What was the mass of water inside the calorimeter for trial 1? For trial 2?
  
  
  
  
  
  
  
  
  
  
2. What was the temperature change of the copper for trial 1? For trial 2?
  
  
  
  
  
  
  
  
  
  
3. What was the temperature change of the water inside the calorimeter for trial 1? trial 2?
  
  
  
  
  
  
  
  
  
  
4. Determine the specific heat capacity of copper for trial 1 and then for trial 2.
  
  
  
  
  
  
  
  
  
  
5. For trials 1 and 2, what was your average specific heat capacity of copper?

Name: \_\_\_\_\_

**Part B Data**

**Trial 1**

**Trial 2**

Unknown letter	_____	_____
Mass of calorimeter	_____	_____
Mass of calorimeter and water	_____	_____
Initial temperature of water inside calorimeter	_____	_____
Mass of unknown metal	_____	_____
Temperature of boiling water bath after 10 minutes	_____	_____
Highest temperature reached of water with metal inside calorimeter	_____	_____

**Part B Calculations. Show your work.**

1. What was the mass of water inside the calorimeter for trial 1? For trial 2?
2. What was the temperature change of the unknown metal for trial 1? For trial 2?
3. What was the temperature change of the water inside the calorimeter for trial 1? trial 2?
4. Determine the specific heat capacity of the unknown metal for trial 1 and then for trial 2.
5. Using your calculated specific heat capacity (or average value if trial 2 was performed), identify the metal. Your instructor will provide a table of select metals and their heat capacities.



## Experiment 5

### Formula of a Hydrated Salt

#### Objectives

1. To determine the percent (by mass) of water in an unknown hydrated salt.
2. To determine the number of water molecules per formula unit of the unknown hydrated salt.

#### Discussion

When aqueous solutions of certain ionic compounds (salts) are allowed to evaporate, some water molecules (*water of hydration*) remain as part of the crystals that are left after evaporation is complete. Such compounds are referred to as *hydrated salts* or simply as *hydrates*. Each hydrate has a definite composition; a certain number of water molecules are combined with each formula unit of the salt. For example,  $\text{CuSO}_4 \cdot 5\text{H}_2\text{O}$  means that 5 water molecules are in chemical combination with each formula unit of  $\text{CuSO}_4$ . Formulas and names of a few common hydrates follow:

$\text{CuSO}_4 \cdot 5\text{H}_2\text{O}$	copper(II) sulfate pentahydrate
$\text{BaCl}_2 \cdot 2\text{H}_2\text{O}$	barium chloride dihydrate
$\text{Na}_2\text{CO}_3 \cdot 10\text{H}_2\text{O}$	sodium carbonate decahydrate

The stability of hydrates varies. Some spontaneously lose their water molecules and others must be heated to high temperature to drive off the water of hydration. Substances which absorb water from the atmosphere are called *hygroscopic* (for example  $\text{CuSO}_4$ ). Some hygroscopic substances (for example  $\text{CaCl}_2$ ) absorb so much water that they form solutions.

The hydrates used in this experiment require some heat to drive off the water of hydration. The resulting water-free compound is called an *anhydrous salt*. The general equation and a specific example follow:

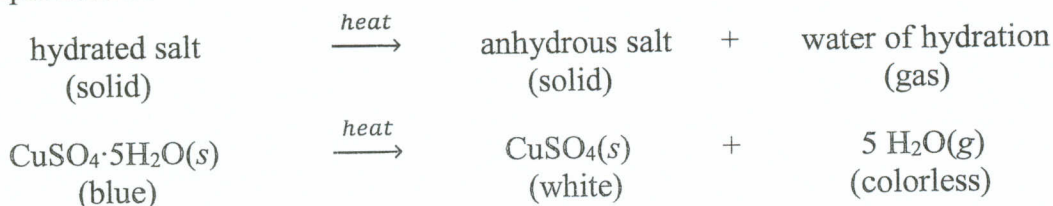

The reaction is reversible. When exposed to moisture, anhydrous salts absorb water to form hydrates. For example:

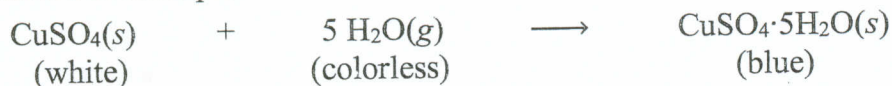

The percent of water in a hydrate can be determined in a manner similar to determining the percent composition of a compound. Experimentally, a hydrate is heated to a constant mass. The decrease in mass of the sample is due to the amount of water lost, and the remaining material is the anhydrous salt. One can determine the mass of water lost from a given amount of hydrate and then calculate the percent of water.

$$\% \text{ water} = \frac{\text{mass of water lost}}{\text{mass of hydrate}} \times 100\%$$

From the mass of water lost, moles of water can be calculated. From the mass of the anhydrous salt and the given molar mass of the anhydrous salt, moles of anhydrous salt can be calculated. The ratio

of these quantities yields the number of water molecules per formula unit of hydrate.

$$\frac{\text{mole of water}}{\text{mass of anhydrous salt}} = \text{molecules of water per formula unit of hydrate}$$

The formula of the hydrated salt is determined by rounding the result of the last equation to the nearest whole number. This number is the value of  $x$  in the formula **salt**· $x$ **H<sub>2</sub>O**. This method of rounding to the nearest whole number works because the hydrated salts used in this experiment all have a ratio of one mole of salt to a whole number moles ( $x$ ) of water.

## Procedure

### A. Preparation of the Crucible

1. Place a clean crucible on a clay triangle supported on a ring stand and heat it with a blue flame for several minutes. Allow it to cool to room temperature. **Do not set the hot crucible on the bench top or on the balance.** After heating you may use the crucible tongs to move the crucible to a ceramic tile until cooling is complete.
2. Until the end of the experiment you may no longer touch the crucible with your fingers or hand. Use crucible tongs only.
3. Weigh the cool, empty crucible. Record the mass on the data sheet. All digits displayed on the electronic balance must be recorded.

### B. Heating the hydrate

1. Obtain an unknown hydrate from the stockroom and record the number on your report sheet.
2. Fill the weighed crucible about 1/3 full with the unknown hydrate and weigh again.
3. Return the crucible containing the hydrate to the clay triangle and heat gently. Please note that it is possible for an unknown to liquefy. If your unknown liquefies see note a, if it does not, see note b:
  - a. For those unknowns that liquefy when heated, use low heat until they resolidify. Then gradually increase the heat, and heat strongly for 10 minutes.
  - b. If the unknown does not liquefy, gradually increase the heat, and heat strongly for 10 minutes.
4. Cool the crucible as before and weigh the crucible and its contents. Record the mass on the data sheet.

### C. Heating to Constant Mass

1. To determine if all the water has been driven off, return the crucible to the clay triangle and heat for an additional 5 minutes.
2. Cool the crucible as before and reweigh. Record the mass on the data sheet.
3. If the two weighings do not agree within 0.04 g, you must heat the crucible and its contents a third time for an additional 5 minutes, cool and reweigh again. This procedure is called "heating to constant mass"; only the anhydrous salt is left in the crucible. Use the mass from your last weighing in your calculations.

### D. Reproducibility of Your Result

Use another portion of your unknown and repeat all of the above steps for trial 2.

Date: \_\_\_\_\_

Name: \_\_\_\_\_

### Experiment 5 "Formula of a Hydrated Salt"

#### Data and Calculations

Unknown Number \_\_\_\_\_

	Trial 1	Trial 2
Mass crucible + hydrate	_____ g	_____ g
Mass of empty crucible	_____ g	_____ g
Mass of hydrate	_____ g	_____ g
Mass of crucible and its content		
after 1 <sup>st</sup> heating	_____ g	_____ g
after 2 <sup>nd</sup> heating	_____ g	_____ g
after 3 <sup>d</sup> heating	_____ g	_____ g
Mass anhydrous salt	_____ g	_____ g
Mass of water lost	_____ g	_____ g
Percent of water (experimental)	_____ %	_____ %

Molar mass of water \_\_\_\_\_ g/mol

Moles of water \_\_\_\_\_ mol

Formula of anhydrous salt (from instructor) \_\_\_\_\_

Molar mass of anhydrous salt \_\_\_\_\_ g/mol

Moles of anhydrous salt \_\_\_\_\_ mol

Moles of water per mole of anhydrous salt \_\_\_\_\_ mol H<sub>2</sub>O / mol salt

Formula of hydrated salt \_\_\_\_\_

Percent of water (theoretical) \_\_\_\_\_ %

$$\text{Percent error} = \frac{|\% \text{ H}_2\text{O (theoretical)} - \% \text{ H}_2\text{O (experimental)}|}{\% \text{ H}_2\text{O (theoretical)}} \times 100\% = \underline{\hspace{2cm}} \%$$

# Determining the Formula of a Hydrate

## Chem Worksheet 11-6

Name \_\_\_\_\_

A **hydrate** is an ionic compound that contains water molecules in its structure. To determine the formula of a hydrate experimentally, we must calculate the mole: mole ratio of the water portion compared to the anhydrate portion. An **anhydrate** is the substance that remains after the water is removed from a hydrate. When a hydrate is heated the water molecules are driven off as steam, leaving behind the water-free anhydrate.

The first step to finding the formula for a hydrate is to record the mass of the hydrate. After heating the hydrate, the mass is determined for the anhydrate that remains. The mass of the water that was present is calculated by finding the difference between the mass of the hydrate and the mass of the anhydrate. The mass of the water and the mass of the anhydrate are each converted to moles using their respective molar masses. From this a whole number ratio can be determined (see example).

**Data Table**

Mass of hydrate (CaCl <sub>2</sub> · xH <sub>2</sub> O)	4.72 g
Mass of anhydrate (CaCl <sub>2</sub> )	3.56 g
Mass of water	1.18 g

### Example

A calcium chloride hydrate has a mass of 4.72 g. After heating for several minutes the mass of the anhydrate is found to be 3.56 g. Use this information to determine the formula for the hydrate.

- find the mass of the water driven off:

$$\text{mass of hydrate} - \text{mass of anhydrate} = \text{mass of water}$$

$$4.72 \text{ g} - 3.56 \text{ g} = 1.18 \text{ g}$$

- convert the mass of anhydrate to moles:

$$\frac{3.56 \text{ g CaCl}_2}{1} \times \frac{1 \text{ mol CaCl}_2}{110.98 \text{ g CaCl}_2} = 0.0321 \text{ mol CaCl}_2$$

- convert the mass of water to moles:

$$\frac{1.18 \text{ g H}_2\text{O}}{1} \times \frac{1 \text{ mol H}_2\text{O}}{18.02 \text{ g H}_2\text{O}} = 0.0655 \text{ mol H}_2\text{O}$$

- find the mole H<sub>2</sub>O to mole CaCl<sub>2</sub> ratio:

$$\frac{0.0655 \text{ mol H}_2\text{O}}{0.0321 \text{ mol CaCl}_2} = \frac{2 \text{ mol H}_2\text{O}}{1 \text{ mol CaCl}_2}$$

Since the compound contains 2 moles of water for every 1 mole of anhydrate the formula is **CaCl<sub>2</sub> · 2 H<sub>2</sub>O**

**Solve the following problems. Show work to support your answer.**

1. A hydrate of magnesium sulfate has a mass of 13.52 g. This sample is heated until no water remains. The MgSO<sub>4</sub> anhydrate has a mass of 6.60 g. Find the formula and name of the hydrate.
2. A sample of copper (II) sulfate hydrate has a mass of 3.97 g. After heating, the CuSO<sub>4</sub> that remains has a mass of 2.54 g. Determine the correct formula and name of the hydrate.
3. When 5.00 g of FeCl<sub>3</sub> · xH<sub>2</sub>O are heated, 2.00 g of H<sub>2</sub>O are driven off. Find the chemical formula and the name of the hydrate.
4. A sample of the hydrate of sodium carbonate has a mass of 8.85 g. It loses 1.28 g when heated. Find the formula and the name of the hydrate.
5. A 16.4 g sample of hydrated calcium sulfate is heated until all the water is driven off. The calcium sulfate that remains has a mass of 13.0 g. Find the formula and the chemical name of the hydrate.
6. When 8.00 g of Pb(C<sub>2</sub>H<sub>3</sub>O<sub>2</sub>)<sub>2</sub> · xH<sub>2</sub>O are heated, 1.14 g of H<sub>2</sub>O are driven off. Find the chemical formula and the name of the hydrate.
7. A hydrate is determined to be 45.43% water and 54.57% CoCl<sub>2</sub>. Find the chemical formula and name for this hydrate. (\*Hint – assume that there is 100 g total of hydrate compound.)

# Nomenclature Worksheet 1

Give either the missing name or formula for the following ions or compounds.

- |                              |       |  |       |
|------------------------------|-------|--|-------|
| 1. cadmium bromide           | _____ | 31. $\text{NaNO}_3$                      | _____ |
| 2. aluminum chloride         | _____ | 32. $\text{H}_3\text{PO}_4$              | _____ |
| 3. zinc phosphate            | _____ | 33. $\text{CuSO}_4$                      | _____ |
| 4. calcium oxide             | _____ | 34. $\text{Al}(\text{ClO}_3)_3$          | _____ |
| 5. mercury (I) chloride      | _____ | 35. $\text{LiOH}$                        | _____ |
| 6. cesium chromate           | _____ | 36. $\text{Ag}_2\text{CrO}_4$            | _____ |
| 7. sodium oxide              | _____ | 37. $\text{Ba}(\text{H}_2\text{PO}_4)_2$ | _____ |
| 8. sodium peroxide           | _____ | 38. $\text{HBr}$                         | _____ |
| 9. potassium carbonate       | _____ | 39. $\text{Mg}(\text{MnO}_4)_2$          | _____ |
| 10. silver sulfite           | _____ | 40. $\text{FeF}_3$                       | _____ |
| 11. lead (II) sulfide        | _____ | 41. $\text{CuO}$                         | _____ |
| 12. silicon dioxide          | _____ | 42. $\text{Cu}_2\text{O}$                | _____ |
| 13. cobalt (II) hydroxide    | _____ | 43. $\text{Hg}_2(\text{CN})_2$           | _____ |
| 14. tin (IV) sulfate         | _____ | 44. $\text{CaCO}_3$                      | _____ |
| 15. lithium bicarbonate      | _____ | 45. $\text{N}_2\text{O}_4$               | _____ |
| 16. dihydrogen phosphate ion | _____ | 46. $\text{N}_2\text{O}$                 | _____ |
| 17. hydrogen phosphate ion   | _____ | 47. $(\text{NH}_4)_2\text{HPO}_4$        | _____ |
| 18. copper (I) hypochlorite  | _____ | 48. $\text{MgSO}_3$                      | _____ |
| 19. iron (II) nitride        | _____ | 49. $\text{LiIO}_3$                      | _____ |
| 20. phosphorus pentabromide  | _____ | 50. $\text{Ba}_3\text{P}_2$              | _____ |
| 21. carbon tetraiodide       | _____ | 51. $\text{NO}_2^-$                      | _____ |
| 22. tin (II) fluoride        | _____ | 52. $\text{CS}_2$                        | _____ |
| 23. stannous fluoride        | _____ | 53. $\text{HgI}_2$                       | _____ |
| 24. calcium periodate        | _____ | 54. $\text{HClO}_4$                      | _____ |
| 25. sulfur trioxide          | _____ | 55. $\text{H}_2\text{O}_2$               | _____ |
| 26. sulfite ion              | _____ | 56. $\text{Sb}_2\text{O}_5$              | _____ |
| 27. mercury (I) phosphite    | _____ | 57. $\text{Pb}(\text{SO}_4)_2$           | _____ |
| 28. zinc carbonate           | _____ | 58. $\text{Sn}(\text{CO}_3)_2$           | _____ |
| 29. sodium bisulfide         | _____ | 59. $\text{HClO}_2$                      | _____ |
| 30. nitric acid              | _____ | 60. $\text{CO}$                          | _____ |

# Nomenclature Worksheet 2

Give either the missing name or formula for the following ions or compounds.

- |                               |       |                                   |       |
|-------------------------------|-------|-----------------------------------|-------|
| 1. calcium bromate            | _____ | 31. $\text{Li}_3\text{PO}_3$      | _____ |
| 2. sodium carbonate           | _____ | 32. $\text{H}_3\text{BO}_3$       | _____ |
| 3. ferric nitrite             | _____ | 33. $\text{Be}(\text{ClO})_2$     | _____ |
| 4. potassium bromite          | _____ | 34. $\text{Mn}_2\text{S}_3$       | _____ |
| 5. <del>cuprous nitride</del> | _____ | 35. $\text{B}_2\text{O}_3$        | _____ |
| 6. chromium (II) chlorite     | _____ | 36. $\text{Al}_2\text{O}_3$       | _____ |
| 7. ammonium phosphite         | _____ | 37. $\text{N}_2\text{O}_5$        | _____ |
| 8. strontium hydroxide        | _____ | 38. $\text{H}_3\text{PO}_4$       | _____ |
| 9. <del>auric iodide</del>    | _____ | 39. $\text{KMnO}_4$               | _____ |
| 10. hypochlorous acid         | _____ | 40. $\text{BeH}_2$                | _____ |
| 11. dinitrogen tetroxide      | _____ | 41. $\text{NH}_3$                 | _____ |
| 12. cadmium sulfide           | _____ | 42. $\text{NH}_4^+$               | _____ |
| 13. hydrochloric acid         | _____ | 43. $\text{SO}_2$                 | _____ |
| 14. sulfite ion               | _____ | 44. $\text{SO}_4^{2-}$            | _____ |
| 15. sulfur trioxide           | _____ | 45. $\text{HF}$                   | _____ |
| 16. chloric acid              | _____ | 46. $\text{HIO}$                  | _____ |
| 17. cuprous selenate          | _____ | 47. $\text{Hg}_2\text{O}$         | _____ |
| 18. lithium perbromate        | _____ | 48. $\text{Hg}(\text{OH})_2$      | _____ |
| 19. zinc iodite               | _____ | 49. $\text{CaS}$                  | _____ |
| 20. aluminum nitrite          | _____ | 50. $\text{Al}_4\text{C}_3$       | _____ |
| 21. boron trichloride         | _____ | 51. $\text{Rb}_2\text{CO}_3$      | _____ |
| 22. calcium hydride           | _____ | 52. $\text{Fe}_3(\text{PO}_4)_2$  | _____ |
| 23. barium hydroxide          | _____ | 53. $\text{NiCrO}_4$              | _____ |
| 24. lead (IV) hypochlorite    | _____ | 54. $\text{CdBrO}_2$              | _____ |
| 25. sulfurous acid            | _____ | 55. $\text{AuI}$                  | _____ |
| 26. nitrous acid              | _____ | 56. $\text{Sb}_2\text{O}_5$       | _____ |
| 27. hydrotelluric acid        | _____ | 57. $\text{Cu}_3(\text{AsO}_3)_2$ | _____ |
| 28. iron (II) nitride         | _____ | 58. $\text{Sn}(\text{ClO}_3)_2$   | _____ |
| 29. mercury (I) ion           | _____ | 59. $\text{HClO}$                 | _____ |
| 30. chromic acid              | _____ | 60. $\text{HIO}_4$                | _____ |

Name: \_\_\_\_\_

### Formula of a compound: Magnesium and Oxygen

**Purpose:** The purpose of this experiment is to determine the empirical formula of magnesium oxide and find its percent composition.

**Background:** In this experiment, the percent composition and empirical formula of magnesium oxide, the main compound that is formed when magnesium metal combines with oxygen in air, will be determined. Heating magnesium in the presence of air causes the metal to ignite and burn – lots of light and heat are given off and a new compound is obtained. According to the law of conservation of mass, the total mass of the products of a chemical reaction must equal the mass of the reactants. In the case of the combustion of magnesium, the following equation must be true:

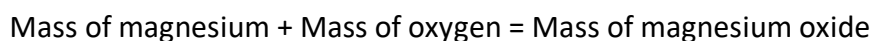

If both the initial mass of magnesium and the final mass of the magnesium oxide are measured, the increase in mass must correspond to the mass of oxygen that combined with magnesium. The percent composition and empirical formula of magnesium oxide can then be calculated, based on the combining ratios of magnesium and oxygen in the reaction. Finally, once the formula of magnesium oxide is known, the amount of magnesium oxide that was produced can be compared against the maximum amount possible based on 100% conversion of the magnesium used in the experiment. This information can be used to calculate the percent yield of magnesium oxide in the reaction.

The two most abundant molecules in air are oxygen and nitrogen. Magnesium primarily reacts with oxygen because it is more reactive than nitrogen. However, some of the magnesium reacts with nitrogen and forms a side product that can be converted to magnesium oxide by adding water.

### Procedures

1. Checkout a metal crucible and lid from the chemistry stockroom.
2. Clean the crucible with sandpaper, distilled water and soap if necessary.
3. Set up a Bunsen burner on a ring stand beneath a ring clamp supporting a clay triangle, and adjust the height of the ring clamp so that the bottom of a crucible sitting in the clay triangle is about 3-4 cm above the burner. Heat the burner in the hottest part of the flame (which is the blue inner cone) for 2-3 minutes. This will remove all the moisture and impurities.
4. Turn off the burner and let your crucible cool down on a wire gauze or ceramic tile on your lab bench.
5. Using tongs to handle the crucible lid and crucible, measure the mass of the clean, dry empty crucible and its lid on the analytical balance. (see Table 1)
6. Weigh about 0.3-0.4 g of magnesium turnings on a beaker or weighing paper.
7. Place the magnesium turnings in the bottom of the crucible.
8. Measure and record the combined mass of the crucible, crucible lid, and magnesium on the same analytical balance you used earlier.
9. Record the appearance of the magnesium before, during, and after heating (see Table 2). Place the covered crucible with its lid (slightly ajar) on the clay triangle. Light the Bunsen

Name: \_\_\_\_\_

burner and brush the bottom of the crucible with the flame for 4 – 5 minutes to slowly heat the crucible and its contents.

10. If the magnesium ignites, or if white smoke appears, close the lid immediately until the burning stops.
11. After slowly heating the crucible, heat the crucible in the hottest part of the flame for 8-10 minutes. **(Figure 1)**
12. After 15 total minutes of heating (this is just an estimate), turn off the gas source, and remove the burner.
13. Using tongs remove the crucible lid and place it on a wire gauze on the bench top. With the tongs, remove the crucible from the clay triangle and place it on the wire gauze as well.
14. Allow the crucible and its contents to cool on the wire gauze for 5 minutes.
15. Add 10 drops of distilled water to the crucible. The water will convert the side product of magnesium nitride into the magnesium oxide product.
16. Place the crucible back on the Bunsen burner setup and heat the crucible, with the lid slightly ajar for 5 minutes on a moderate flame followed by 5 minutes of heating on an intense flame.
17. Cool the crucible and its contents to room temperature (~10 minutes).
18. Measure and record the combined mass of the crucible, crucible lid, and magnesium oxide product.
19. Repeat Steps 16-18 until the mass is within 0.002 g between measurements. This is because you are heating to constant mass. You must do a 2<sup>nd</sup> heating, and depending on your technique, you may need to do additional heatings.
20. Discard the contents of the crucible into the waste container and carefully clean the crucible and crucible lid. Use sandpaper if necessary.



**Figure 1: Crucible setup for heating on a Bunsen burner.**

Name: \_\_\_\_\_

**Data Table:**

**Table 1. Mass data for magnesium oxide combustion reaction.**

Mass of crucible and lid (g)	Mass of crucible, lid, and Mg turnings (g) before heating	Mass of crucible, lid, and product after 1 <sup>st</sup> heating (g)	Mass after 2 <sup>nd</sup> heating, required (g)	Mass after 3 <sup>rd</sup> heating, if needed (g)	Mass after additional heating(s), if needed (g)

**Table 2. Appearance data for magnesium oxide combustion reaction.**

Appearance of Mg before heating	Appearance of Mg during heating	Appearance of product	Appearance of product	Appearance of product	Appearance of product

**Calculations:**

a. Mass of product: \_\_\_\_\_

b. Mass of magnesium: \_\_\_\_\_

c. Mass of oxygen: \_\_\_\_\_

d. Moles of magnesium: \_\_\_\_\_

e. Moles of oxygen: \_\_\_\_\_

f. Ratio of moles of Magnesium to moles of oxygen: \_\_\_\_\_

g. Empirical formula of magnesium oxide: \_\_\_\_\_

h. Experimental % of magnesium in your product: \_\_\_\_\_

$$\% Mg = \frac{\text{mass of magnesium (g)}}{\text{mass of product (g)}} \times 100\%$$

Name: \_\_\_\_\_

- i. Actual formula of magnesium oxide (based on charge of Mg and O): \_\_\_\_\_
- j. Theoretical mass % of Mg based on the actual formula of magnesium oxide. (Hint: you will need the molar mass of magnesium and magnesium oxide).
- k. Percent error in % Mg:

$$\% \text{ error} = \frac{\text{experimental value} - \text{theoretical value}}{\text{theoretical value}} \times 100\%$$

### Discussion questions

1. Write the balanced chemical equation for the formation of magnesium oxide.
2. Magnesium nitride is an impurity formed by the reaction of magnesium with nitrogen. Write down the balanced chemical equation for the formation of magnesium nitride.
3. What happens when we add water to magnesium nitride? Write down the balanced chemical equation. Hint: one of the product is ammonia: (NH<sub>3</sub>).
4. Discuss two sources of error in this experiment that might account for a high percentage error in % Mg .

Name: \_\_\_\_\_

## Chemical Reactions

**Purpose:** Perform qualitative observations of chemical changes.

### Procedure:

1. **Reactions with oxygen:** Synthesis or combination reactions. Demonstration, in the fume hood, by the instructor.

a. Metal + Oxygen  $\rightarrow$  Metal oxide

a. The metal used is magnesium.

Reactants	Products	Observations
Write the balanced chemical equation		

b. Non-metal + oxygen non-metal oxide

a. The non-metal used is sulfur

Reactants	Products	Observations
Write the balanced chemical equation		

Obtain a spot plate from the stock room. Check for cleanliness.

The different reagents for each set of reactions are in tub stations located either in the fume or along the perimeter of the laboratory. Do not change substances from one station to another.

Liquids and solutions are placed in flip top containers or bottles with droppers. Do not take off the top of the flip top containers, you can dispense dropwise each substance through the top (flipped).

Add few drops for each reaction (enough to see the changes)

For reactions with a solid and a liquid add, add a piece of the solid and enough liquid to cover it.

Perform each reaction in a different well of the plate.

When you finish, empty the reagents in the waste container located in the fume hood, wash and dry the plate before you return it to the stock room.

Name: \_\_\_\_\_

## 2. Single displacement reactions

- a. Copper wire and silver nitrate solution.
- b. Magnesium turnings and 0.1 M hydrochloric acid.
- c. Copper wire and 0.1 M hydrochloric acid

a.

Reactants	Products	Observations
Write the balanced chemical equation		

b.

Reactants	Products	Observations
Write the balanced chemical equation		

c.

Reactants	Products	Observations
Write the balanced chemical equation, include phase labels		

Organize the elements tested in order of increased reactivity

## 3. Double displacement reactions: Precipitations.

The following are all aqueous solutions.

- a. Silver nitrate and ammonium carbonate
- b. Iron (III) chloride and sodium hydroxide
- c. Copper (II) nitrate and sodium phosphate

a.

Reactants	Products	Observations
Write the balanced chemical equation, include phase labels.		

b.

Reactants	Products	Observations
Write the balanced chemical equation, include phase labels.		

c.

Reactants	Products	Observations
Write the balanced chemical equation, include phase labels.		

Name: \_\_\_\_\_

#### 4. Double Displacement reactions: Acid base neutralizations.

Add exactly six drops of the acid to each of the reactions and a small drop of phenolphthalein indicator. Add sodium hydroxide base dropwise, with stirring, until you see the solution turns pink and the pink color stays. Report the drops of base required to neutralize each acid.

- a. Nitric acid
- b. Sulfuric acid
- c. Phosphoric acid

a.

Reactants	Products	Drops required for neutralization
Write the balanced chemical equation, include phase labels.		

b.

Reactants	Products	Drops required for neutralization
Write the balanced chemical equation, include phase labels.		

c.

Reactants	Products	Drops required for neutralization
Write the balanced chemical equation, include phase labels.		
All the acid solutions have the same molar concentration. Why do they require different amounts of the base for neutralization?		

#### 5. Decomposition reactions. Do these reactions in test tubes.

- a. Hydrate: Add a few crystals of copper (II) sulfate pentahydrate to a test tube. Hold the test tube with a test tube holder and use a Bunsen burner to heat the sample until you observe a color change.

Reactants and color	Products and color	Observations
Write the balanced chemical equation, include phase labels		
What is the liquid that condenses at the top of the test tube?		

Name: \_\_\_\_\_

- b. Carbonate: Add a small amount of ammonium carbonate to a test tube. Heat the test tube holding a moist piece of litmus paper, with tongs, in the mouth of the test tube. Record the color of the litmus paper before and after the reaction.

Reactants	Products	Color change of the pH paper
Write the balanced chemical equation, include phase labels		
What substance caused the change in the litmus paper?		

6. **Exothermic and endothermic processes.** Place two test tubes in a test tube rack and add approximately three milliliters of water to each one.

- a. Note the temperature of the water touching the test tube. Add the tip of the spatula of potassium chloride. Touch the test tube again to detect the temperature change.  
There are arguments on whether dissolving ionic compounds in water is a chemical or a physical change. In this lab, we will treat it as a chemical change.

Reactants	Products	Exothermic or endothermic?
Write the balanced chemical equation including the heat term		

- b. Note the temperature of the water touching the test tube. Add the tip of the spatula of calcium chloride anhydrous and touch the test tube again to detect the temperature change. Calcium chloride anhydrous is hazardous to the skin and eyes.

Reactants	Products	Exothermic or endothermic?
Write the balanced chemical equation, including the heat term		

Name: \_\_\_\_\_

### 7. Double displacement, gas forming reaction:

- a. Add approximately two milliliters of aqueous sodium carbonate to a test tube. Hold the test tube, with a test tube holder, on top of the sink. Add hydrochloric acid, dropwise, until you observe evolution of gas.

Reactants	Products	Observations
Write the double displacement reaction and balance it		
Write the balanced chemical equation of the reaction that produces the gas observed		
Write the overall, balanced, reaction including phase labels		

### Questions

1. Do all chemical reactions show, like the ones in this experiment, evidence of the change that can be detected with our senses?
  
  
  
  
  
  
  
  
  
  
2. What is an activity series?
  
  
  
  
  
  
  
  
  
  
3. Is the reaction in a cold pack exothermic or endothermic?

Name: \_\_\_\_\_

### Determination of a Reaction Yield

1. Obtain the masses, separately, of (2) 50 mL beakers.
2. Add between 0.75 and 1.00 g of the copper(II) chloride hydrate salt to each beaker.
3. Add enough 6M HCl to dissolve the solid. Each sample will require between 5-10 mL of acid. Do not add more than 10 mL of HCl to each beaker. Be sure to continually swirl the mixture.
4. Perform a mass-to-mass conversion and calculate how many grams of magnesium metal are required to react. Your instructor will guide you.
5. Multiply step 4 by 1.5. Obtain this new amount of magnesium twice. Do not combine the two batches.
6. Slowly add one batch of magnesium to one of the beakers containing your mixture. Repeat with the second mixture.
7. If there is any magnesium in the mixture that has not reacted, add an additional 1-2 mL of HCl.
8. When the reaction is done, decant (pour off) the liquid into a separate waste beaker.
9. Add 5 mL of deionized water to the copper residue, swirl, and decant into the waste beaker.
10. Dry the copper metal by placing its beaker on a hot plate.
11. Using thermal gloves, remove the beaker and set aside to cool. Determine the mass.
12. Discard all waste into the appropriate container.

<b>Data</b>	<b>Trial 1</b>	<b>Trial 2</b>
Mass of 50 mL beaker	_____	_____
Mass of copper salt	_____	_____
Stoichiometric mass of Mg	_____	_____
1.5 × stoichiometric mass of Mg	_____	_____
Mass of beaker containing dried copper residue	_____	_____

Name: \_\_\_\_\_

**Questions/Calculations. Show your work.**

1. Write the balanced chemical equation for today's reaction.
2. Which reactant was the limiting reagent? How do you know?
3. Based on your answer to question 2, determine the theoretical yield of copper for each trial.
4. Determine the actual yield of copper for each trial.
5. Determine the percent yield of copper. If two trials were performed, calculate the average percent yield.
6. If the copper was still wet when massed, how would this affect your percent yield? Explain.

Name: \_\_\_\_\_

## Flame Test

### Procedure:

1. Put on your approved safety goggles.
2. Add 10 drops of each 1 M solution to a different clean well in your well-plate:

HCl (1 M)	MgCl <sub>2</sub> (1 M)	CuCl (1 M)
LiCl (1 M)	CaCl <sub>2</sub> (1 M)	CuCl <sub>2</sub> (1 M)
NaCl (1 M)	SrCl <sub>2</sub> (1 M)	
KCl (1 M)	BaCl <sub>2</sub> (1 M)	

3. Set up a Bunsen burner with a blue flame (showing an inner blue cone):



4. Obtain either a platinum wire or a nichrome wire. Clean the looped end of the wire by dipping it into the 1 M HCl solution, remove and place the looped end of the wire into the hottest part of the Bunsen burner flame (the tip of the inner blue cone) until the only color observable is the blue color of the flame itself – this usually takes 3-5 seconds (no longer).
5. When the wire is clean, dip the looped end of the wire into the 1 M LiCl solution, remove and place the looped end of the wire into the hottest part of the Bunsen burner flame (the tip of the inner blue cone) for 3-5 seconds only. Observe and record (using colored pencils) any color produced during this 3-5 second period. Clean the looped end of the wire by dipping it into the 1 M HCl solution, remove and place the looped end of the wire into the hottest part of the Bunsen burner flame (the tip of the inner blue cone) until the only color observable is the blue color of the flame itself – this usually takes 3-5 seconds (no longer).

Name: \_\_\_\_\_

- Repeat step 5 for each new chemical solution in the well-plate.
- Obtain one or two unknown solutions (1, 2) from the lab instructor. Add 10 drops of each unknown 1 M solution to a different clean well in your well-plate:

HCl (1 M)	MgCl <sub>2</sub> (1 M)	CuCl (1 M)
LiCl (1 M)	CaCl <sub>2</sub> (1 M)	CuCl <sub>2</sub> (1 M)
NaCl (1 M)	SrCl <sub>2</sub> (1 M)	1 (1 M)
KCl (1 M)	BaCl <sub>2</sub> (1 M)	2 (1 M)

- Repeat step 5 for each unknown solution. Unknown solution 1 and 2 will be the same chemical(s) used elsewhere in the well-plate. Identify the unknown solution(s) by comparing the flame color(s) to those already recorded earlier.
- Repeat steps 4-8 using a hand-held spectroscope:



- Use the spectroscope (which contains a diffraction grating) to observe the color of the flame for each of the solutions and unknown(s) in the well-plate. Use colored pencils to record the appearance of the flame for each solution as seen through the spectroscope.
- Return all items used in this experiment and wash your work station and hands with soap and water. Finally, remove your safety goggles.

Name:

**Results:**

Use colored pencils to color in each well-plate below from steps 5-7.

HCl (1 M)	MgCl <sub>2</sub> (1 M)	CuCl (1 M)
LiCl (1 M)	CaCl <sub>2</sub> (1 M)	CuCl <sub>2</sub> (1 M)
NaCl (1 M)	SrCl <sub>2</sub> (1 M)	1 (1 M)
KCl (1 M)	BaCl <sub>2</sub> (1 M)	2 (1 M)

Use colored pencils to represent your observation for each well through the spectroscope from steps 8-10.

HCl	
LiCl	
NaCl	
KCl	
MgCl <sub>2</sub>	
CaCl <sub>2</sub>	
SrCl <sub>2</sub>	
BaCl <sub>2</sub>	
CuCl	
CuCl <sub>2</sub>	
Unknown 1	
Unknown 2	
Unknown 1 =	
Unknown 2 =	

Name: \_\_\_\_\_

**Discussion Questions:**



The following questions relate to the three spectra (plural of spectrum) shown above:

1. Which (if any) of the three spectra shown resemble the observations you made using your hand-held spectroscope?
  
  
  
  
  
  
  
  
  
  
2. How would you describe the three spectra shown? (Some online research may be required)

Name: \_\_\_\_\_

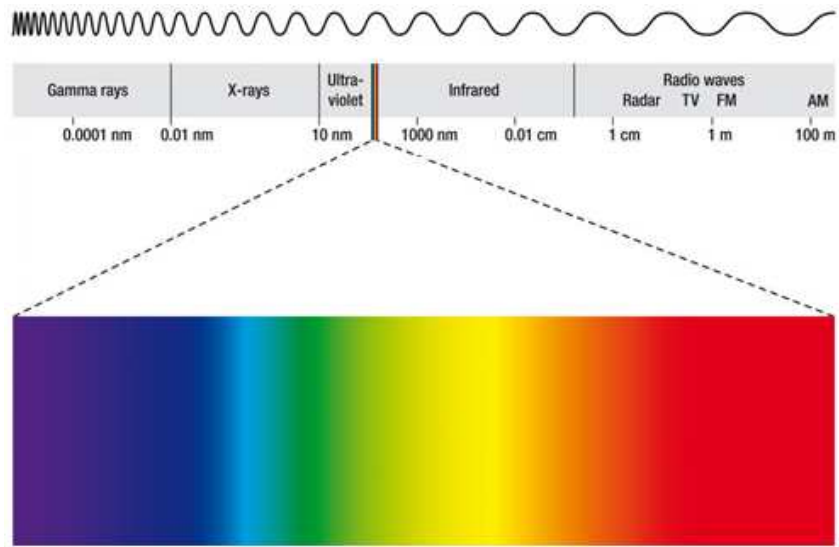

The following questions relate to the spectrum above:

3. How would you describe the relationship between the wavelength of visible light and its frequency?
4. How would you describe the appearance of the visible spectrum?
5. How would you describe the relationship between the color of visible light and its energy?
6. Suppose a wave of visible light of wavelength equal to 555 nm were traveling at a velocity of 55.5 cm/s past a point "A". How long would it take for one wavelength of the light to travel past the point "A"?

**Name:** \_\_\_\_\_

7. How would your answer to question 6 change (if at all) if the wavelength of the light was increased beyond 555 nm?

8. What is responsible for the observations made during this experiment?

**Conclusions:**

Identify the cause of the flame test observations made in this experiment and write a short conclusion based on your observations and from any ideas introduced in the “Discussion Questions” above (1 paragraph).

**Future questions:**

What questions does do you have now you’ve finished this experiment? (ask at least 1 question)

Name: \_\_\_\_\_

## Charles' Law

**Purpose:** The purpose of this experiment is to experimentally verify Charles' Law.

**Background:** Jacques Charles was a French scientist who in 1787 observed that the volume of a gas is directly proportional to its absolute (Kelvin) temperature when the pressure and the number of moles of the gas are kept constant. Thus, the volume of a gas will increase when the temperature is increased and the volume of a gas will decrease with a decrease in temperature. Mathematically, this law can be expressed as :

$$\frac{V_1}{T_1} = \frac{V_2}{T_2} \qquad \text{Equation 1}$$

Where  $V_1$  and  $V_2$  are the initial and final volumes of the gas at temperatures  $T_1$  and  $T_2$  respectively. Please note that the temperature measurements have to be expressed in Kelvin. In this experiment, you will verify Charles' Law by measuring the volume of air at two different temperatures while maintaining a constant pressure. Then you will compare the volume measured with the calculated volume using Equation 1.

**YouTube video:** Click on the link below for the lab setup. This will give you an idea of how the lab is carried out.

[https://www.youtube.com/watch?v=5M8GR6\\_zlps](https://www.youtube.com/watch?v=5M8GR6_zlps)

### Procedures

1. Checkout the rubber stopper and tubing assembly from the chemistry stockroom.
2. You also need a 125 mL Erlenmeyer flask, a 600 mL beaker ( a 400 mL beaker will also work), hot plate (or Bunsen burner, ring stand and wire guaze), a plastic tray or pan and a utility clamp.
3. First, dry the 125 mL Erlenmeyer flask by heating it on a Bunsen flame. Make sure that there are no traces of moisture left in the flask.
4. Clamp the 125 mL flask to the beaker and add DI water to the beaker up to the neck of the flask. **(Figure 1)**
5. Heat the flask by boiling the water inside the beaker.
6. While the water is boiling, fill the plastic tray with enough cool water to cover and submerge the flask.
7. Measure the temperature of the boiling water and record it as  $T_1$  on your data table.
8. When the air in the flask has been heated for more than five minutes in the boiling water, crimp the rubber tubing with a tubing clamp, hold the flask with your utility clamp and immerse it in the tray of cool water.
9. Continue holding the flask under water and remove the tubing clamp from the rubber tubing. At this point water will enter the flask as it cools down. Keep the flask under water as the temperature of the flask equilibrates with the temperature of the cool water.
10. After five minutes, measure the temperature of water in the tray and record it on your data table as  $T_2$ .

Name: \_\_\_\_\_

11. To make sure that the pressure of the flask is the same as the atmospheric pressure, raise or lower the flask until the water levels in the flask and in the tray are equal. This will ensure that the experiment is carried out at constant pressure. **(Figure 2)**
12. Now, close the tubing in the flask and take it out of the pan. Measure the volume of water in the flask using the 50 mL graduated cylinder. Record the volume of water on your data table as  $V_{H_2O}$ .
13. To measure the initial volume of air in the flask ( $V_1$ ). Fill the entire flask with DI water up to the brim, insert the rubber stopper and tubing, then remove the stopper and tube, and measure the water in the flask using a 250 mL graduated cylinder.
14. Measure the barometric pressure in the laboratory and record it on the data table.
15. Refer to Table 1, look up the vapor pressure of water at  $T_2$ , and record it on your data table as **P water**.
16. Dry the flask thoroughly and repeat the procedure a second time.
17. To complete the data table refer to the calculations section.

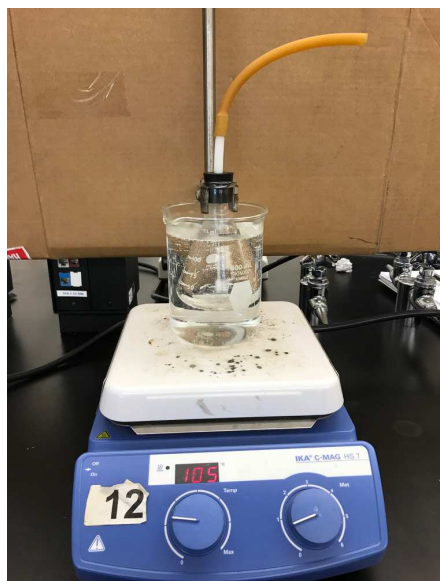

Figure 1. Heat flask in a boiling water bath.

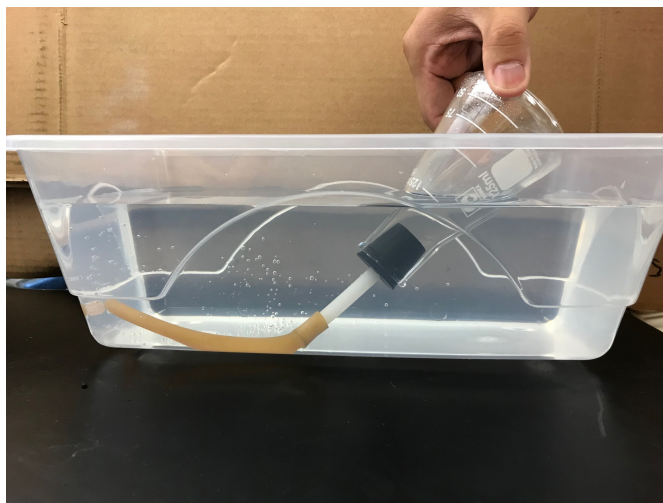

Figure 2. Adjust the water level in the flask to match the level in the bath.

Name: \_\_\_\_\_

**Data Table:**

	Trial 1	Trial 2
Temperature of boiling water ( $T_1$ )		
Temperature of air after cooling on the water bath ( $T_2$ )		
Initial volume of air in the flask at the temperature of boiling water ( $V_1$ )		
Volume of water drawn into the flask ( $V_{H_2O}$ )		
Volume of moist air ( $V_2$ wet) drawn into the flask when cooling. $V_2$ wet = $V_1 - V_{H_2O}$		
Volume of air collected at the cool temperature after the vapor pressure correction in Equation 2. ( $V_2$ measured)		
Volume of air collected at the cool temperature calculated using Charles' Law ( $V_2$ calculated)		
Atmospheric pressure in mmHg ( $P_{total}$ )		
Water vapor pressure (in mmHg) at temperature $T_2$ ( $P_{water}$ ) (from Table I)		
Percent error between $V_2$ measured and $V_2$ calculated		

**Table I. Vapor Pressure of Water as a Function of Temperature**

*Temperature (°C)    Vapor Pressure (mm)    Temperature (°C)    Vapor Pressure (mm)*

10	9.2	20	17.5
11	9.8	21	18.6
12	10.5	22	19.8
13	11.2	23	21.1
14	12.0	24	22.4
15	12.8	25	23.8
16	13.6	26	25.2
17	14.5	27	26.7
18	15.5	28	28.3
19	16.5	29	30.0
		30	31.8

Name: \_\_\_\_\_

**Calculations:**

- a. The air collected in the flask at the lower temperature also contains water vapor. So we refer to this volume as **V<sub>2 wet</sub>**. We can calculate **V<sub>2 wet</sub>** by subtracting the volume of water (**V<sub>H<sub>2</sub>O</sub>**) drawn into the flask from the initial volume of air in the flask **V<sub>1</sub>**.
- b. In order for us to calculate the volume of air collected at the cool temperature (**V<sub>2 measured</sub>**), we have to use a vapor pressure correction. This correction is done using the Daltons Law of Partial Pressures. In Equation 2, we subtract the vapor pressure of water in the flask at the cooler temperature to calculate the experimental value of V<sub>2</sub> (**V<sub>2 measured</sub>**).

$$V_2 \text{ measured} = V_2 \text{ wet} \times \frac{P_{\text{total}} - P_{\text{water}}}{P_{\text{total}}} \quad \text{Equation 2}$$

- c. Using Charles' Law calculate the theoretical value for V<sub>2</sub> (**V<sub>2 calculated</sub>**) by substituting values for V<sub>1</sub>, T<sub>1</sub> and T<sub>2</sub> in equation 1. Show your work below.

- d. Calculate the Percent error in between your experimental and theoretical value for V<sub>2</sub>:

$$\% \text{ error} = \frac{|V_2 \text{ measured} - V_2 \text{ calculated}|}{V_2 \text{ calculated}} \times 100\%$$

Show your work for calculating % error:



Name: \_\_\_\_\_

## The Shape of Molecules

**Purpose:** Determine polarity of molecules.

Check out a molecular model kit from the stock room. Check that the kit contains linear, trigonal planar, tetrahedral, trigonal bipyramidal and octahedral electron geometries.

1. Complete the following table and build the model for each. Show the model to the instructor.

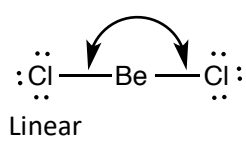
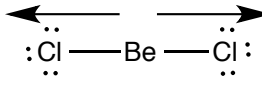
Species Valence electrons	Lewis structure	Electron geometry Show angles	Molecular geometry Dipole moment (If any)
BeCl <sub>2</sub> 16	$\begin{array}{c} \text{:}\ddot{\text{Cl}}\text{---Be---}\ddot{\text{Cl}}\text{:} \\ \text{:}\ddot{\text{Cl}}\text{---Be---}\ddot{\text{Cl}}\text{:} \end{array}$	$180^\circ$  <p style="text-align: center;">Linear</p>	Linear $\mu = 0$  non-polar
CO <sub>2</sub>			
BCl <sub>3</sub>			
NH <sub>3</sub>			
H <sub>2</sub> O			

Name: \_\_\_\_\_

CH <sub>4</sub>			
SF <sub>4</sub>			
ICl <sub>3</sub>			
PF <sub>5</sub>			
SF <sub>6</sub>			



Name: \_\_\_\_\_

## Compounds in Solution

**Purpose:** Study the property of ionic and molecular compounds

### Procedure

#### 1. Solubility of ionic compounds in water

Add approximately 4 milliliters of water to a test tube. Use its height to add the same amount of water to two other test tubes.

Add the tip of the spatula of each of the solids to different test tubes. Add more or less the same amount to each one. Mix the contents of the test tubes tapping the bottom of the test tube with the thumb. Observe if it is soluble, insoluble or slightly soluble. Save the samples for the conductivity test.

- b. Ammonium chloride
- c. Calcium sulfate
- d. Calcium hydroxide

Formula of the compound	Cation and anion	Solubility in water
a)		
b)		
c)		

#### 2. Polarity of molecular compounds

- a. Solubility in water, a polar substance.** Add approximately 4 milliliters of water to a test tube. Use its height to add the same amount of water to two other test tubes.

Add sugar, the tip of the spatula, to one of the test tubes. Mix and observe if it is soluble (polar) or insoluble (non-polar). Iodine reacts with metals, use a wooden splint to transfer few crystals to the water in the second test tube. Use a clip to make a hole in the vitamin E capsule and squish into the third test tube. Save the test tube(s) with solutions (dissolved substances) for the conductivity test.

- a. Sucrose
- b. Iodine
- c. Vitamin E

Name: \_\_\_\_\_

Compound	Formula	Polar or non-polar?
a)		
b)		
c)		
Water		

- b. **Solubility in hexane, a non-polar substance.** Add approximately four milliliters of hexane to a test tube. Use its height to add the same amount of water to two other test tubes.

Add sugar, the tip of the spatula, to one of the test tubes and observe if it is soluble (non-polar) or insoluble (polar) in hexane. Iodine reacts with metals, use a wooden splint to transfer few crystals to the hexane in the second test tube. Use a clip to make a hole in the vitamin E capsule and squish into the third test tube.

- a. Sucrose
- b. Iodine
- c. Vitamin E

Compound	Formula	Polar or non-polar?
a)		
b)		
c)		
Hexane		

### 3. Electrolyte solutions

Test the conductivity probe with the conductivity of deionized water.

Assess the conductivity of the solutions in part 1 experiment "Solubility of ionic compounds in water". Record relative brightness of the LED as +, ++ or +++.

Assess the conductivity of the sample(s) that dissolved in the experiment 2a "Solubility of molecular compounds in water"

Compound	Formula	Relative brightness. Electrolyte, weak electrolyte or non-electrolyte.
Deionized water		
Aqueous ammonium chloride		
Aqueous calcium sulfate		
Aqueous calcium hydroxide		
Soluble molecular compound		

Name: \_\_\_\_\_

#### 4. Solubility of carbon dioxide in water as a function of temperature

Add approximately 40 ml of carbonated water and two drops of bromothymol blue indicator to a 250- milliliter beaker. Record the color of the solution. Bring to a boil on a hot plate, turn it off and observe the color change. Bromothymol blue is yellow in acid solutions and blue in neutral or basic solutions.

	Acidic or basic?
Color of solution before boiling	
Color of solution after boiling	
Write the equation for the reaction responsible for the acidity of the carbonated water	
What causes the change in acidity with increasing temperature?	

#### 5. Solubility of potassium permanganate in water as a function of temperature.

Add approximately 25 milliliters of water to two 100-ml beaker. Heat it on a hot plate and turn it off just before boiling.

Add few crystals of potassium permanganate to each beaker and record the intensity of color at the times in the table as +, ++, +++ etc.

Time minutes	Permanganate dissolved in hot water	Permanganate dissolved in cold water
0		
5		
10		
What happens to the solubility of the permanganate in the cold water?		
What happens to the solubility of permanganate in the hot water?		

#### 6. Precipitation of ions in solution.

Wash the spot plate from the previous experiment and add few drops of each of the ions in solution.

a) Add few drops of ammonium carbonate and record the appearance of a precipitate. If a precipitate forms, write the net ionic equation.

Solution	Precipitate	NIE
KCl <sub>(aq)</sub>		
BaCl <sub>2(aq)</sub>		
SrCl <sub>2(aq)</sub>		
CaCl <sub>2(aq)</sub>		



## Titration

### Part A.

#### Standardization of approx. a 0.1M NaOH solution.

1. Measure about 0.720 g of KHP (Potassium hydrogen phthalate  $\text{KHC}_8\text{H}_4\text{O}_4$ ) on a weighing paper
2. Transfer the measured KHP to a 250 ml Erlenmeyer flask.
3. Measure 50 ml of deionized water using a graduated cylinder and transfer the water to the flask containing the KHP.
4. Add three drops of Phenolphthalein indicator to the dissolved KHP.
5. Condition the burette by rising it with 5- 15 ml of NaOH solution. Discard this solution in the waste container.
6. Place the burette in the ring stand as shown in the figure below:



Fig 1. Burette on a ring stand.

7. Fill the burette with the NaOH solution making sure that there are no bubbles in the tip of the burette.
8. Record the initial volume of NaOH in the burette.
9. Place the Erlenmeyer flask under the burette (it is recommended to place a piece of white paper under the Erlenmeyer flask. (See picture below).

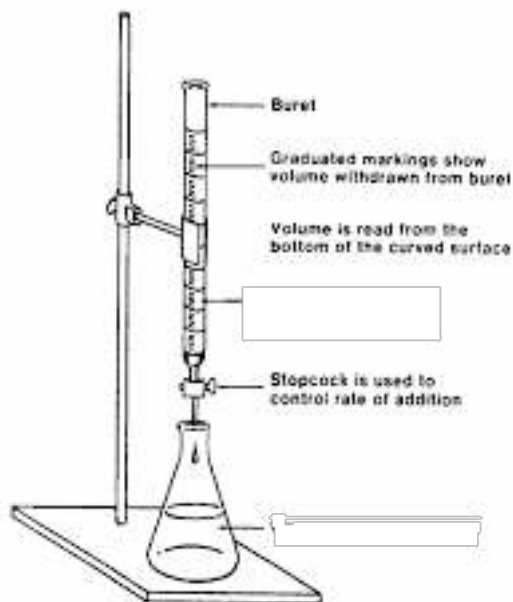

Figure 2. Set up for titration.

10. Titrate the KHP solution until the equivalence point is reached.
- 11 Record the volume of NaOH added to reach the equivalence point.
12. Repeat the titration two more times, for a total of 3.
13. Before proceeding to the second part of the experiment compute the average molarity of the NaOH solution and show the calculations to your instructor.

Part 2. Concentration of acetic acid in vinegar.

1. Transfer 4 – 5 ml of vinegar from the burette in the chemical hood to a 125 ml Erlenmeyer flask and dilute to a total volume of 50 ml with deionized water.
2. Add 3 drops of phenolphthalein indicator.
3. Re-filled the burette with the standardized NaOH solution. Record the initial volume.
4. Titrate the vinegar, with the NaOH solution, to the equivalence point.
5. Repeat the process for a total of three times.
6. Compute the average molarity of the Acetic Acid in the vinegar sample.

Data and results.  
Standardization of NaOH.

Data	Trial 1	Trial 2	Trial 3
Mass of KHP			
Initial volume of NaOH			
Final volume of NaOH			
Volume of NaOH added to equivalence point			
Molarity of NaOH			
Average molarity			

Calculations:

Data and results.  
Titration of Vinegar.

Data and results	Trial 1	Trial 2	Trial 3
Initial volume of NaOH			
Final volume of NaOH			
Volume of NaOH added to the equivalence point			
Molarity of acetic acid in vinegar			
Average Molarity			

Calculations.